

2023 Install Full Line Product Catalog

Contents

About JBL	4-7	JBL Pro Soundbar	29	Live Portable PA Speakers	68-78	JBL Commercial Series	89
Ceiling Loudspeakers	8-15	JBL Pro Soundbar	29	PRX400 Series	68-69	About JBL Commercial	89
CSS Commercial Series	8	Column Loudspeakers	30-33	EON700 Series	70-71	Commercial Series Amplifiers	90-91
8100 Series	9	CBT Series	30-32	PRX900 Series	72-73	Commercial Mixer/Amps	92-94
Control 10 Series	10-11	COL Series	33	SRX800 Series	74-75	Commercial Mixers	95
Control 20 Series	12	Beam Forming Columns	34-37	EON ONE Compact	76	Wall Controllers	96
Control 40 Series	13	Intellivox Series	34-37	EON ONE MKII	77	Training	97
Control 200 Series	14	Pointsource Loudspeakers	38-52	PRXONE	78	Software Tools	98-99
Control 300 Series	15	AE Application Engineered Speakers	38	Studio Monitors	79-80	3 Series MKII	98
Surface Mount Loudspeakers	16-22	About AE Pointsource Loudspeakers	39	7 Series	80	7 Series	80
Control Contactor 20 Series	16-17	AM Speakers	40	Cinema Speakers	81-88	200 Series	81
CSS Commercial Series	18	AE Subwoofers	41-42	Screen Array 3-way	82	Screen Array 3-way	82
Control 50 Series	19	AE Expansion Series	43-44	High Power Screen Arrays	83	High Power Screen Arrays	83
Control Pro Series	20	AE Compact Loudspeakers	45	Surround Systems	84-85	Surround Systems	84-85
Control CRV Series	21	All Weather Compact Series	46	Cinema Subwoofers	86	Cinema Subwoofers	86
Control HST Series	22	AW All Weather Series Full Size	47-48	Cinema Amplifiers	87	Cinema Amplifiers	87
Pendant Loudspeakers	23-24	CWT Series	49	CPI 2000 Processor	88	CPI 2000 Processor	88
Control 80 Series	23-24	PD500 Series	50				
In-wall Loudspeakers	25	PD600 Series	51				
Control 100 Series	25	PD700i Series	52				
Landscape Loudspeakers	26	Installed Audio	53-67				
Control 80 Series	26	VLAi Series	53				
GSF Series	27	VLA Compact Series	54-55				
GSB Series	28	VRX900 Series	56-57				
		VTX A-Series	58-59				
		VTX V-Series	60-61				
		VTX F Series	62				
		VTX-M Series	63				
		VTX Subwoofers	64-65				
		SRX900 Series	66-67				

Contact Us.

For more information on JBL Professional Loudspeakers and Commercial Audio products for your next project visit us at www.jblpro.com



About JBL.

Power And Versatility Are Just The Beginning.

When it comes to innovating audio, JBL Professional never ceases to raise the bar. Since our inception more than 75 years ago, our brand has become synonymous with epic sound. And while the enjoyment is instinctive, the science behind each innovation is precise and methodical. Passionate and gifted engineers and designers around the world devote themselves to developing JBL products and solutions that take listening to the next level—and they've been striving for those goals since day one.



JBL Professional solutions encompass recording studios, movie theatres, tour sound, installed sound, arenas and stadiums, hospitality venues, houses of worship and much more. At the heart of each solution are a meticulous attention to detail, a drive to develop everything from the ground up, and an unwavering dedication to giving music makers outstanding sound, whether they're performing at a major music festival or busking on a street corner. The technologies that we develop for professionals benefit all audiophiles and music fans as we distill them into compact form factors, letting both content creators and listeners enjoy professional-quality sound in convenient, easy-to-use tools and at affordable prices.



Over the decades, JBL has pioneered a remarkable number of engineering firsts and innovations that cemented our reputation as an industry leader, garnering Grammy® Awards, Academy Awards, and accolades from the world's most celebrated musicians and customers alike along the way.



Fusing a bold vision of the future with the extraordinary passion and talent of our engineers and designers, we develop our own solutions, invent our own technologies, and create our own tools, with a pioneering spirit that has defined the brand for more than seven decades. Today, JBL is in more than 130 countries, encompasses an increasingly diverse range of next-level products and solutions, and has more than 300 patents to our name, for groundbreaking technologies like the VGC™ transducer, Slip Stream™ low-frequency port, Progressive Transition™ (PT) waveguide and Plus One™ woofer cone.



Thanks to our enduring dedication to surpassing customer expectations, JBL sound has become part of the fabric of people's lives. Whether it's cinema sound that delivers more immersive movie-going experiences, soundbars that transform living rooms into concert halls, portables that let listeners enjoy their favorite tunes whenever they go, gaming headsets that make players swear they've stepped inside the action, or in-car audio technology that transforms daily commutes into moments of pure listening pleasure, JBL fills listeners' lives with sound as it was meant to be heard.

A Journey of Engineering Excellence.



Audio technology is at the core of everything JBL does. For more than 75 years, we've employed the best methodologies and tools, developing everything from the ground up, guaranteeing our efforts exceed the needs and expectations of audio professionals throughout the world. Never straying from this exacting formula, we've produced a prolific list of audio achievements, groundbreaking technologies, and revolutionary advances in the art and science of professional audio, earning many patents and awards along the way. It's a journey that is legendary worldwide and has positioned JBL as the world leader in professional audio—not just as a brand, but as a company known for continually blending creativity and science as a manifestation of our passion for sound and commitment to those who create it.

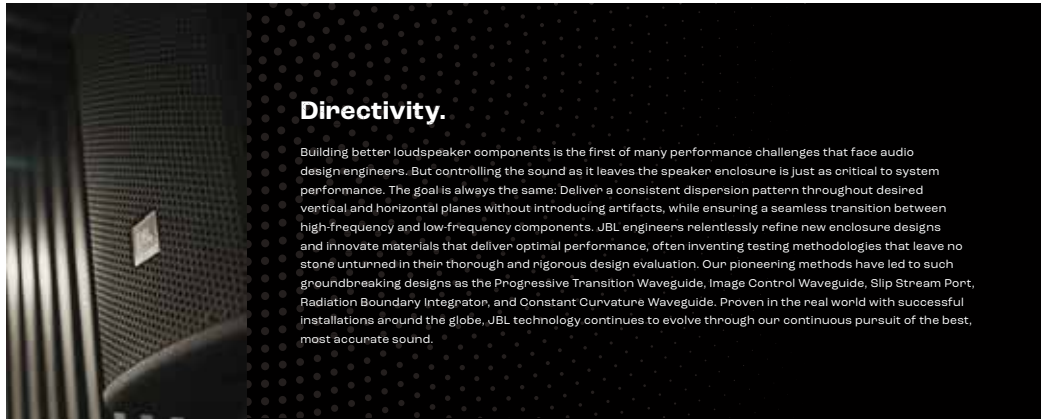

Directivity.

Building better loudspeaker components is the first of many performance challenges that face audio design engineers. But controlling the sound as it leaves the speaker enclosure is just as critical to system performance. The goal is always the same: Deliver a consistent dispersion pattern throughout desired vertical and horizontal planes without introducing artifacts, while ensuring a seamless transition between high-frequency and low-frequency components. JBL engineers relentlessly refine new enclosure designs and innovate materials that deliver optimal performance, often inventing testing methodologies that leave no stone unturned in their thorough and rigorous design evaluation. Our pioneering methods have led to such groundbreaking designs as the Progressive Transition Waveguide, Image Control Waveguide, Slip Stream Port, Radiation Boundary Integrator, and Constant Curvature Waveguide. Proven in the real world with successful installations around the globe, JBL technology continues to evolve through our continuous pursuit of the best, most accurate sound.

Transducers.

The JBL engineering legacy began in transducer technology. Building on our founder James B. Lansing's historic foundation, JBL engineers continue to break ground on new and better ways to design transducers, reaching beyond the "possible" and consistently setting new performance benchmarks for the audio industry. Designing products from the ground up has led to us innovating technologies such as Differential Drive woofers, CMOD Cone Midrange drivers, and the D2 Dual Voice Coil Compression Driver, that cover the entire range of professional audio tools. Addressing performance-nobbing challenges in power compression, heat dissipation, distortion, component weight, and physical footprint, we've developed a range of transducers that are unparalleled in their ability to deliver extraordinary performance in a wide range of applications.



RADIATION BOUNDARY INTEGRATOR™ (RBI)

JBL's patented Radiation Boundary Integrator combines a large-diameter high-frequency waveguide with low-frequency projection apertures that work in tandem to ensure the transition across each band is uninterrupted, undistorted, and seamless. A patented, tuned resonant chamber is integrated into the waveguide itself, effectively eliminating throat-related cancellations due to back pressure from the mid-range section. Our refined RBI waveguide implementation delivers improved horizontal coverage—broader and more stable.



DIFFERENTIAL DRIVE®

JBL's exclusive dual-voice coil, dual-magnetic-gap Differential Drive technology reduces speaker weight while enhancing critical performance attributes including better heat dissipation, lower power compression and higher dynamic range, compared to conventional single-coil designs. The result is very high output with minimal power compression and deep, distortion-free bass even at very high SPLs. Differential Drive technology is at the core of a range of woofer models incorporated in JBL loudspeaker systems supporting touring, fixed installations, recording studios and cinemas.



FEATURING D2 DUAL DIAPHRAGM DUAL VOICE COIL COMPRESSION DRIVER

D2 DUAL DIAPHRAGM DUAL VOICE COIL COMPRESSION DRIVER

The revolutionary D2 Dual Diaphragm Dual Voice Coil Compression Driver dramatically improves high-frequency performance, offering an extreme output advantage over conventional systems, with significantly higher array power and reduced distortion, thanks to double the number of voice coils and more than double the power handling. This results in a dramatic increase in pure high-frequency sound pressure levels with a 30-percent reduction in weight in the same physical footprint.



Testing.

All audio products have a useful life, and JBL engineers are committed to making your investment last as long as possible—not only in terms of reliability, but in terms of how great your system sounds every time you turn it on. Every JBL Professional product undergoes stringent testing above and beyond the conditions products face when deployed in the real world.



JBL research facilities feature multiple application-specific anechoic testing chambers and showcase our "Speaker Shuffler"—the only one of its kind—which allows rapid and precise re-positioning of speaker systems in the exact same precise position, for unrivaled accuracy in A/B testing. Our rigorous, uncompromising testing methodologies result in continuous performance breakthroughs and ensure that JBL customers worldwide can always work with confidence.

CEILING SPEAKERS



Grande Centre Point, Thailand

CSS Commercial Series.

ENTRY-LEVEL BACKGROUND MUSIC AND PAGING SPEAKERS

The JBL CSS Commercial Series provides affordable performance for paging and background music applications in retail stores, restaurants, schools and other facilities.

CSS8004 100mm (4IN) COMMERCIAL SERIES CEILING SPEAKERS

The CSS8004 is a 100mm (4in) speaker with 90dB sensitivity and a 5-Watt multi tap transformer. The speaker's triple-voltage transformer provides versatility by allowing use on 100V, 70V, or 25V distributed loudspeaker lines. Available in White.

- Transducer: 100mm
- Dispersion: 175° Conical
- Response: 85Hz-18kHz
- Sensitivity: 90dB
- Power: 15W 8Ω (5W Tx)



CSS8008 200mm (8IN) COMMERCIAL SERIES CEILING SPEAKERS

The CSS8008 is a 200mm (8in) speaker with 96dB sensitivity and a 5-Watt multi tap transformer. The speaker's triple-voltage transformer provides versatility by allowing use on 100V, 70V, or 25V distributed loudspeaker lines. Available in White.

- Transducer: 200mm
- Dispersion: 120° Conical
- Response: 55Hz-16kHz
- Sensitivity: 96dB
- Power: 15W 8Ω (5W Tx)



CSS8018 200mm (8IN) COMMERCIAL SERIES CEILING SPEAKERS

The CSS8018 is a high-powered 200mm (8in) speaker with 97dB sensitivity and a 10-Watt multi tap transformer. The speaker's triple-voltage transformer provides versatility by allowing use on 100V, 70V, or 25V distributed loudspeaker lines. Available in White.

- Transducer: 200mm
- Dispersion: 110° Conical
- Response: 50Hz-17kHz
- Sensitivity: 97dB
- Power: 20W 8Ω (10W Tx)



CSS15C-VA 127mm (5IN) CEILING LOUDSPEAKER FOR EN54-24 APPLICATIONS

A full-range, EN54-24 certified ceiling speaker consisting of a 127mm (5in) full-range dual cone driven, torsion-mounted into an included easy-install blind-mount metal fire dome. The speaker is designed to provide clear and intelligible sound for applications requiring EN54 certification and/or BS5839 compliance. Available in White.

- Transducer: 125mm
- Dispersion: 120° Conical
- Response: 180Hz-20kHz
- Sensitivity: 92dB
- Power: 6W Tx



ACCESSORIES FOR CSS8004/8008/8018

MTC-BB4X6: Pre-install backcan for CSS8004. Pack of 6 pieces.
MTC-BB6X6: Pre-install backcan for CSS8008 and CSS8018. Pack of 6 pieces.
MTC-TR4/Bx12: Tile rails for CSS-BB4 and CSS-BB6 backcans. Pack of 12 pieces for 6 speakers.

8100 Series.

SCULPTED GRILLE DUAL-CONE CEILING SPEAKERS

High sensitivity at a cost-effective price point, the 8100 Series is an easy to install loudspeaker solution for a wide variety of commercial sound applications. With its contemporary grille design, the 8100 Series loudspeakers are ideal for a variety of settings ranging from restaurant and retail settings to professional offices and reception areas. All models feature 6W transformer for 70V/100V distributed lines.

8124 100mm (4IN) FULL-RANGE, IN-CEILING LOUDSPEAKER

The 8124 is a 100mm (4in), full-range, loudspeaker, featuring a high sensitivity driver that provides 130° conical coverage in a lightweight 1.2kg package and includes dog-ears for easy blind mount installations. Available in White.

- Transducer: 100mm
- Dispersion: 130° Conical
- Response: 60Hz-18kHz
- Sensitivity: 93dB
- Power: 20W 8Ω (6W Tx)



8128 200mm (8IN) FULL-RANGE, IN-CEILING LOUDSPEAKER

The 8128 is a 200mm (8in), full-range loudspeaker featuring a high sensitivity driver that provides 90° conical coverage in a lightweight 1.4kg package and includes dog-ears for easy blind mount installations. Available in White.

- Transducer: 200mm
- Dispersion: 90° Conical
- Response: 50Hz-16kHz
- Sensitivity: 97dB
- Power: 25W 8Ω (6W Tx)



The 8124 and 8128 Ceiling Speakers are designed with built-in dog-ears for fast and easy installations, and are lightweight with open-back design for applications not requiring an in-ceiling backcan.

8138 200mm (8IN) FULL-RANGE, IN-CEILING LOUDSPEAKER

The 8138 is a 200mm (8in), full-range loudspeaker designed for use with MTC-81BB8 pre-install in-ceiling backcan, resulting in high sensitivity performance at a cost effective price point. Available in White.

- Transducer: 200mm
- Dispersion: 90° Conical
- Response: 95Hz-18kHz
- Sensitivity: 97dB
- Power: 25W 8Ω (6W Tx)



ACCESSORIES

Because of the very light weight of 8124 and 8128, tile rails may not be required for some in-ceiling applications. They are not packaged with these models, however MTC-RAIL tile rail sets and MTC-8124C and MTC-8128C C-rings are available separately.

The 8138 is designed for use with MTC-81BB8 backcan and MTC-81TB8 tile bridge.



Control 10 Series.

AFFORDABLE BLIND-MOUNT CEILING SPEAKERS

Control 10 Series in-ceiling loudspeakers meet the increased market demand for superior sound quality, installation-friendly features and value, delivering a level of sonic performance unmatched by comparably priced products. They are ideal for applications where excellent sound quality is needed for medium-volume music playback and paging.

Control 10 Series models feature wide bandwidth, wide coverage, and combined 70V/100V and 8 ohm operation in each speaker. Dual conduit clamp allows separate strain reliefs for the input and loop out cables. High humidity grilles are available to suit Control 12, 14 and 16 models.



Toyota Buzz Vibhavadi Headquarters, Thailand

CONTROL 12C/T

76mm (3IN) COMPACT CEILING LOUDSPEAKER

The Control 12C/T is a high fidelity speaker with a 76mm (3in) full-range driver and a wide frequency range of 68Hz to 17kHz. The short 120mm (4.7in) blind-mount backcan allows for easy installation in shallow ceiling spaces. Available in Black or White.

- Transducer: 76mm
- Dispersion: 130° Conical
- Response: 95Hz-15kHz
- Sensitivity: 84dB
- Power: 20W 8Ω (15W Tx)



Also available: Control 12C-VA – EN54-24 Certified for life safety applications

CONTROL 14C/T

100mm (4IN) TWO-WAY COAXIAL IN-CEILING LOUDSPEAKER

The Control 14C/T contains a co-axially mounted 100mm (4in) woofer and 19mm (3/4in) soft dome tweeter. The liquid-cooled soft dome tweeter provides clear, pleasant sound over a wide coverage area. Blind-mount backcan for quick and easy installation. Available in Black or White.

- Transducer: 100mm+19mm
- Dispersion: 120° Conical
- Response: 74Hz-20kHz
- Sensitivity: 87dB, D, WG
- Power: 30W 8Ω (25W Tx)



Also available: Control 14C-VA – EN54-24 Certified for life safety applications

CONTROL 16C/T

165mm (6.5IN) TWO-WAY COAXIAL IN-CEILING LOUDSPEAKER

Control 16C/T is a full-range ceiling speaker consisting of a 165mm (6.5in) high tech cone driver and a 19mm soft-dome liquid cooled tweeter mounted in a vented, paintable baffle made of UV resistant UL94-V0 and UL94-5HB material, with a pre-attached blind-mount backcan for quick and easy installation. Available in Black or White.

- Transducer: 165mm+19mm
- Dispersion: 110° Conical
- Response: 62Hz-20kHz
- Sensitivity: 91dB, D, WG
- Power: 50W 8Ω (30W Tx)



Also available: Control 16C-VA – EN54-24 Certified for life safety applications

CONTROL 18C/T

200mm (8IN) TWO WAY COAXIAL CEILING LOUDSPEAKER

Control 18C/T is a full-range ceiling speaker consisting of a 200mm (8in) high tech cone driver and a 25mm soft dome liquid cooled tweeter mounted in a vented, paintable baffle made of UV resistant UL94-V0 and UL94-5HB material, with a pre-attached blind-mount backcan for quick and easy installation. The speaker is designed to provide excellent sound quality for a wide variety of medium to high volume applications. Available in Black or White.

- Transducer: 200mm+25mm
- Dispersion: 90° Conical
- Response: 58Hz-20kHz
- Sensitivity: 92dB, D, WG
- Power: 90W 8Ω (60W Tx)



ACCESSORIES

- New Construction Brackets & Trim Rings: The Control 10 Series speaker utilizes the Control 20 Series NC New Construction Brackets, MR Plaster Ring Brackets, and TR Trim Rings.
- Control 12C/T and 14C/T utilize MTC-24NC, MR & TR
- Control 16C/T utilizes MTC-26NC, MR & TR
- MTC-48TRx12: Tile Rails for (4' x 4') ceiling tiles (pack of 12 rails)

- High Humidity Grilles:
- MTC-14WG (White) fits Control 12C/T and 14C/T
 - MTC-14WG-BK (Black) fits Control 12C/T-BK and 14C/T-BK
 - MTC-16WG (White) fits Control 16C/T
 - MTC-16WG-BK (Black) fits Control 16C/T-BK

Control® Contractor 20 Series. PREMIUM SMALL-FORMAT CEILING SPEAKERS

JBL Control Contractor 20 Series small-format ceiling speakers provide full-range, high-fidelity sound reinforcement for background music and music-plus-paging systems. Innovative features like titanium-coated tweeters and JBL's proprietary diffraction-horn loading technology deliver extremely wide, even coverage, meaning fewer speakers are required for any installation. Models are packaged as complete assemblies including grilles, backcan and tile nails, and can be installed without accessing areas above the ceiling. All speakers feature JBL's exclusive SonicGuard™ overload protection, enabling higher operational levels and improving reliability. Control Contractor 20 Series ceiling speakers are voiced similarly to other JBL Control Contractor models, allowing them to be combined with in-wall and surface-mount speakers in a single listening space.

CONTROL 24C MICRO, 24CT MICRO & 24CT MICROPLUS 115mm (4.5in) BACKGROUND MUSIC CEILING LOUDSPEAKER

The Control 24C/CT Micro AND 24CT MicroPlus are compact and easy to install in-ceiling speakers providing full, high quality sound for background music and music-plus-paging systems. The 24CT Micro includes a 9W multi-tap transformer and the 24CT MicroPlus includes a 25W multi-tap transformer. Available in White.

- Transducer: 115mmx12mm
- Dispersion: 150° (Asym)
- Response: 85Hz-25kHz (Control 24CT MicroPlus 80Hz-25kHz)
- Sensitivity: 86dB, D
- Power: 15W 8Ω C / 9W Tx CT (Control 24CT MicroPlus: 25W Tx)



CONTROL 24C, 24CT & 24CT-BK 100mm (4in) BACKGROUND/FOREGROUND CEILING LOUDSPEAKER

The Control 24C contains a coaxially mounted 4in woofer and 3/4in titanium coated tweeter providing high fidelity sound over a wide coverage area. The 24CT is available in Black (C24CT-BK).

- Transducer: 115mmx19mm
- Dispersion: 130° Conical
- Response: 80Hz-20kHz
- Sensitivity: 86dB, D, WG
- Power: 40W 16Ω C / 30W Tx CT



CONTROL 26C, 26CT & 26CT-LS 165mm (6.5in) BACKGROUND MUSIC CEILING LOUDSPEAKER

The Control 26C contains a coaxially mounted 165mm (6.5in) woofer and 3/4in titanium coated tweeter, able to deliver maximum sound level over a defined area. The 26CT provides a 70V/100V multi-tap transformer. The 26CT-LS is UL1480/UUMW life safety certified. Available in White.

- Transducer: 165mmx19mm
- Dispersion: 110° Conical
- Response: 75Hz-20kHz / 80Hz-20kHz -LS
- Sensitivity: 89dB, D, WG
- Power: 75W 16Ω C / 60W Tx CT, -LS



CONTROL 26-DT 165mm (6.5in) COAXIAL CEILING SPEAKER

The Control 26-DT is a compact ceiling speaker assembly configured to install into standard ceiling backcans designed for 200mm (8in) drivers. Available in Black.

- Comes complete with transducer, network and transformer
- Transducer: 165mmx19mm
- Dispersion: 90° Conical
- Response: 70Hz-20kHz
- Sensitivity: 89dB, D, WG
- Power: 60W Tx



CONTROL 19CS & 19CST 200mm (8in) IN-CEILING SUBWOOFER

The Control 19CS uses advanced proprietary technologies to produce powerful bass from a low profile in-ceiling design. The optional 19CST has a special subwoofer band transformer for 70V/100V operation. Available in White.

- Transducer: 200mm
- Response: 42Hz-200Hz
- Sensitivity: 95dB
- Power: 100W 8Ω CS / 75W Tx CST



ACCESSORIES

- New Construction Bracket: MTC-xxNC* - Plaster Ring Bracket: MTC-xxMR*
 - Trim Rings: Allow for installation into existing ceiling speaker cutouts that are larger than the speaker's normal cutout size. MTC-xxTR*
 - MTC-4BTRx12: Tile Rails for 4' x 4' ceiling tiles (pack of 12 nails)
 - High humidity grille MTC-16WG (white) fits Control 26C and 26CT.
- *These models are available in different sizes. Specify speaker model when ordering.

www.jblpro.com

Control® 40 Series. EXTENDED PERFORMANCE SMALL-FORMAT CEILING SPEAKERS WITH CONICAL RBI

The Control 40 Series Ceiling Speaker are designed to work perfectly in environments that require a premium, in-ceiling speaker with an extremely wide bandwidth and consistent coverage. Consisting of three 165mm (6.5in) coaxial models, a 60mm (2.5in) ultra-compact satellite speaker and in-ceiling subwoofer, the Control 40 Series can be configured in many different ways to accommodate a full range of applications. JBL focused on ease-of-installation by including an integrated backcan, grille and tile nails (except Control 42C), locking 2-pin connectors and two knockouts. The Control Series speakers are designed for use in air handling spaces.

CONTROL 42C 60mm (2.5in) ULTRA COMPACT SATELLITE SPEAKER

The Control 42C is an ultra-compact in-ceiling satellite loudspeaker designed for use with the Control 40CS/T subwoofer. It offers an unobtrusive design which is ideal for a wide range of installations. Available in White.

- Transducer: 50mm
- Dispersion: 150° Conical
- Response: 340Hz-20kHz
- Sensitivity: 92dB
- Power: 15W 16Ω



CONTROL 45C/T 130mm (5.25in) COAXIAL CEILING RBI™ LOUDSPEAKER

The Control 45C/T is a premium loudspeaker designed for applications that can benefit from extremely wide bandwidth and very consistent coverage from a ceiling speaker with a small footprint. Available in White.

- Transducer: 130mmx20mm
- Dispersion: 120° Conical
- Response: 55Hz-20kHz
- Sensitivity: 88dB, D, WG
- Power: 75W 8Ω (60W Tx)



CONTROL 47C/T & 47LP 165mm (6.5in) COAXIAL CEILING RBI™ LOUDSPEAKER

The Control 47C/T and Control 47LP are designed for applications that require extremely wide bandwidth and very consistent coverage. The Control 47LP (Low Profile backcan) is identical to Control 47 but equipped with a shallow backcan for use in areas with restricted mounting depths. Available in White.

- Transducer: 165mmx25mm
- Dispersion: 120° Conical
- Response: 55Hz-20kHz / 68Hz 47LP
- Sensitivity: 91dB, D, WG
- Power: 75W 8Ω (60W Tx)



CONTROL 47HC 165mm (6.5in) COAXIAL HIGH CEILING RBI™ LOUDSPEAKER

The Control 47HC is designed for applications that require a narrow focused beamwidth pattern and very consistent coverage, such as for increasing clarity, intelligibility and SPL when in high-ceiling applications. Available in White.

- Transducer: 165mmx25mm
- Dispersion: 75° Conical
- Response: 55Hz-17kHz
- Sensitivity: 93dB, D, WG
- Power: 75W 8Ω (60W Tx)



CONTROL 40CS/T 200mm (8in) HIGH IMPACT CEILING SUBWOOFER

The Control 40CS/T is a direct radiating, high impact 8in subwoofer designed for powerful bass response in an in-ceiling loudspeaker. It features a built in crossover network and four high-passed outputs enabling it to be used as a sub/sat system. Available in White.

- Transducer: 200mm
- Response: 32Hz-300Hz
- Sensitivity: 89dB
- Power: 100W 8Ω (80W Tx)



ACCESSORIES

- New Construction Bracket: MTC-xxNC* - Plaster Ring Bracket: MTC-xxMR*
 - Trim Rings: Allow for installation into existing ceiling speaker cutouts that are larger than the speaker's normal cutout size. MTC-xxTR*
 - MTC-4BTRx12: Tile Rails for 4' x 4' ceiling tiles (pack of 12 nails).
- *These models are available in different sizes. Specify speaker model when ordering.

www.jblpro.com

Control® 200 Series.
MEDIUM-FORMAT CEILING SPEAKERS

Control 226C/T, 227C and 227CT are premium in-ceiling speakers designed to meet the increasing market demand for premium quality sound in ceiling-mount applications. The Control 200 Series loudspeakers incorporate breakthrough performance features such as best-in-class pattern control to provide a consistent sound throughout the listening area. Especially wide coverage allows fewer speakers to cover the space, reducing both the material and labor cost for the installation. The high-power kevlar-reinforced 6.5in (165mm) low-frequency driver along with the titanium-diaphragm compression driver and the advanced-technology steep-slope crossover provide superb, wide-bandwidth sound quality.

Control® Contractor 300 Series
LARGE-FORMAT CEILING SPEAKERS



Control 300 Series represents the state of the art in large-format ceiling loudspeaker systems. True point-source coax designs, multiple power levels and transformer choices, plus an in-ceiling subwoofer, make it easy to fulfill any system performance requirements. Premium components include Kevlar-reinforced cones, low-saturation transformers and legendary JBL compression drivers. Advanced high-slope crossover networks, combined with low system distortion and smooth frequency response provides full, natural music along with exceptional speech intelligibility.



CONTROL 226C/T
Control 200 models are available both in an independent backcan design (Control 227C & 227CT) and in an integrated backcan version (Control 226C/T).

CONTROL 226C/T
165mm (6.5in) COAXIAL CEILING LOUDSPEAKER WITH HF COMPRESSION DRIVER

Control 226C/T is a compact, easy-to-install speaker with integrated backcan for blind-mounting into ceilings. It features a top-quality 60W multi-tap transformer for 70V/100V line distribution systems. The transformer may be bypassed, allowing the Control 226C/T to be used as a low-impedance 8 ohm speaker. C-ring, tile rails and grille are included. This model is designed to be able to utilize the optional MTC-19NC new construction ring and MTC-19MR plaster-ring for new construction projects requiring pre-installation rings. Available in White.

- Transducer: 165mm x 25mm
- Dispersion: 120° Conical
- Response: 47Hz-19kHz
- Sensitivity: 90dB, CD
- Power: 100W 8Ω (68W Tx)



CONTROL 328C & 328CT
200mm (8in) COAXIAL CEILING LOUDSPEAKER WITH HF COMPRESSION DRIVER

The Control 328C has a 8in woofer and 1in compression driver engineered from the ground up to deliver exceptional performance in a coaxial point source design ceiling speaker. The optional Control 328CT includes 70V/100V multi-tap transformer.

- Transducer: 200mm x 25mm
- Dispersion: 100° Conical
- Response: 45Hz-18kHz
- Sensitivity: 93dB, CD
- Power: 150W 8Ω C / 68W Tx CT



CONTROL 321C & 321CT
300mm (12in) COAXIAL CEILING LOUDSPEAKER WITH HF COMPRESSION DRIVER

The Control 321C has a 12in woofer and 1in compression driver engineered from the ground up to deliver exceptional performance in a coaxial point source design ceiling speaker. The optional Control 321CT includes 70V/100V multi-tap transformer.

- Transducer: 300mm x 25mm
- Dispersion: 90° Conical
- Response: 34Hz-18kHz
- Sensitivity: 94dB, CD
- Power: 200W 8Ω C / 68W Tx CT



CONTROL 227C & 227CT
165mm (6.5in) COAXIAL CEILING LOUDSPEAKER WITH HF COMPRESSION DRIVER

Control 227C is a high-output, low-impedance 8 ohm speaker assembly for installation with the separate MTC-200BBB backcan and MTC-RG6/8 grille (both sold separately). Optional accessories include MTC-19NC new construction ring, MTC-19MR plaster-ring, and MTC-TB6/8 tile bridge. Control 227CT is a 70V/100V version of Control 227C, featuring a top-quality 60W multi-tap transformer for 70V/100V line distribution systems.

- Transducer: 165mm x 25mm
- Dispersion: 120° Conical
- Response: 43Hz-19kHz
- Sensitivity: 90dB, CD
- Power: 100W 8Ω C / 68W Tx CT



CONTROL 322C & 321CT
300mm (12in) HIGH OUTPUT COAXIAL CEILING SPEAKER

The Control 322C has a high output 12in woofer and 1in compression driver engineered from the ground up to deliver exceptional performance in a coaxial point source design ceiling speaker. The optional Control 322CT includes 70V/100V multi-tap transformer.

- Transducer: 300mm x 37mm
- Dispersion: 90° Conical
- Response: 32Hz-20kHz
- Sensitivity: 95dB, CD
- Power: 250W 8Ω C / 100W Tx CT



ACCESSORIES
• MTC-200BBB: Backcan for Control 227C and 227CT. 337mm (13.3in) max diameter x 206mm (8.1in) deep

• MTC-RG6/8: Round grille for Control 227C and 227CT. Also fits Control 328C & 328CT. 345mm (13.6in) in diameter

• MTC-SG6/8: Square grille for Control 227C and 227CT. Also fits Control 328C & 328CT. 340mm (13.4 in) x (340 mm)

• MTC-TB6/8: Tile bridge for Control 227C and 227CT. Also fits Control 328C & 328CT.

• MTC-19NC & MTC-19MR: New-construction and mud rings fit Control 228 for new construction applications requiring pre-installation rings.



CONTROL 227C & 227CT
Assembly with backcan and grille.

CONTROL 312CS
300mm (12in) HIGH OUTPUT IN-CEILING SUBWOOFER SPEAKER

The Control 312CS is a high output 12in subwoofer that is an excellent addition to JBL Control 321, 322, and 328 loudspeaker systems.

- Response: 30Hz-4kHz
- Sensitivity: 93dB
- Power: 250W 8Ω



ACCESSORIES
Premium accessories include best-in-class black boxes made of heavy 16 gauge metal and lined with 1/2 MDF, as well as contemporary grilles and an optional higher power transformer. A variety of grilles are available.

SURFACE-MOUNT SPEAKERS



Indegwon Catholic Church, South Korea

Control Contractor 20 Series. SURFACE-MOUNT SPEAKERS

JBL Control Contractor 20 Series surface-mount speakers and subwoofers deliver full, rich sound; deep bass extension; high SPL output; and wide, consistent coverage for retail stores, restaurants, health clubs, theme parks, educational facilities or any application demanding top-quality sound reinforcement in a rugged, compact package.

Built-in JBL Invisible™ mounting technology makes installation a breeze. Outdoor capabilities can be further enhanced with optional IP55 WeatherMax™ grilles. Control Contractor surface-mount speakers are voiced similarly to other JBL Control Contractor models, allowing them to be combined with in-wall and in-ceiling speakers in a single listening space. The Control Contractor 20 line balances superior fidelity with versatility, ease-of-installation and contemporary style. Models feature IP44 weather-resistant transducers and enclosures.



CONTROL 23-1 ULTRA-COMPACT INDOOR/OUTDOOR BACKGROUND/FOREGROUND SPEAKER

The Control® 23-1 is a two-way 3in speaker with rich sonic character, wide coverage, consistent dispersion, versatile mounting, and a contemporary high-design look that fits into a wide range of decors. Available in Black or White.

Also available: Control 23-1L - 8 ohm only

- Dispersion: 100°x 100° HxV
- Response: 70Hz-20kHz
- Sensitivity: 86dB, D, WG
- Power: 40W 8Ω (15W Tx)
- Environmental: IP-44



CONTROL 25-1 COMPACT INDOOR/OUTDOOR BACKGROUND/FOREGROUND SPEAKER

The Control® 25-1 is a two-way 5in speaker with rich sonic character, wide coverage, consistent dispersion, versatile mounting, and a contemporary high-design look that fits into a wide range of decors. Available in Black or White.

Also available: Control 25-1L - 8 ohm only

- Dispersion: 100°x 100° HxV
- Response: 60Hz-20kHz
- Sensitivity: 90dB, D, WG
- Power: 75W 8Ω (30W Tx)
- Environmental: IP-44



CONTROL 28-1 HIGH-OUTPUT INDOOR/OUTDOOR BACKGROUND/FOREGROUND SPEAKER

The Control® 28-1 is a two-way 8in speaker with rich sonic character, wide coverage, consistent coverage, versatile mounting, and a contemporary high-design look that fits into a wide range of decors. Available in Black or White.

Also available: Control 28-1L - 8 ohm only

- Dispersion: 100°x 100° HxV
- Response: 45Hz-20kHz
- Sensitivity: 91dB, D, WG
- Power: 90W 8Ω (60W Tx)
- Environmental: IP-44



CONTROL 25-AV & 25-AVLS COMPACT BACKGROUND/FOREGROUND SPEAKER

The Control 25 is an especially wide band-width, smooth response speaker. It features a top quality 70V/100V transformer for distribution systems which can also be bypassed for use as an 8 ohm speaker. The Control 25AV-LS is UL1480 UUMW listed for use in fire alarm and/or emergency communication systems. Also EN52-24 certified.

Available in Black or White.

- Dispersion: 100°x 100° HxV
- Response: 70Hz-23kHz
- Sensitivity: 87dB, D, WG
- Power: 100W 8Ω (60W Tx)
- Environmental: IP-X4



CONTROL 29AV-1 PREMIUM INDOOR/OUTDOOR MONITOR SPEAKER

The Control 29AV-1 utilises high power components and a complex network to achieve smooth high fidelity performance and a well-controlled defined coverage from a compact loudspeaker. Available in Black or White.

- Dispersion: 110°x85° HxV
- Response: 37Hz-18kHz
- Sensitivity: 90dB
- Power: 150W 8Ω (110W Tx)
- Environmental: IP-X4



CONTROL 30 3-WAY HIGH OUTPUT INDOOR/OUTDOOR MONITOR SPEAKER

The Control 30 is a three-way high output speaker designed for multiple uses. Weather resistance has been maximised, making the Control 30 suitable for outdoor applications. Includes 70V/100V multi-tap transformer. Available in Black or White.

- Dispersion: 120°x120° HxV
- Response: 38Hz-17kHz
- Sensitivity: 93dB
- Power: 250W 4Ω (150W Tx)
- Environmental: IP-X5



CONTROL 31 2-WAY HIGH OUTPUT INDOOR/OUTDOOR MONITOR SPEAKER

The Control 31 utilises high-power components, computer optimised horn, and a complex network to achieve smooth, powerful high-fidelity performance, extended bandwidth, and well-controlled defined coverage from a compact loudspeaker. Available in Black or White.

- Dispersion: 110°x110° HxV
- Response: 33Hz-19kHz
- Sensitivity: 92dB
- Power: 200W 8Ω (150W Tx)
- Environmental: IP-55



CONTROL SB2 DUAL COIL 250MM (10in) COMPACT SUBWOOFER

The Control SB-2 functions as the subwoofer section of left/right music systems, preserving the stereo separation. The dual coil 10in transducer has been optimised to compliment four Control 23 speakers. Available in Black.

- Response: 38Hz-160Hz
- Sensitivity: 97dB
- Power: 170W 8Ω (x2)



CONTROL SB2210 DUAL 250MM COMPACT SUBWOOFER

The Control SB2210 provides low frequency reinforcement for a wide variety of sound system applications. Its compact size, high output and outdoor capable design makes it one of the most versatile subwoofers in the installation market. Available in Black.

- Response: 42Hz-200Hz
- Sensitivity: 95dB
- Power: 400W 8Ω
- Environmental: IP-45



ACCESSORIES

MTC-PC2: The MTC-PC2 Panel Cover provides sealed entrance protection for input terminals and strain relief for incoming speaker wire.

MTC-xxBG and MTC-xWBG: SB2 stainless steel retrofit grilles for Control 23, 25, and 28. WMG WeatherMax™ grilles add a foam and tight-waves backing to break up driving rain.

MTC-xH* Horizontal Array Brackets: Allows horizontal arraying of two Control 23, 25 or 28 speakers. MTC-H brackets can be interconnected to form a suspended ring for mounting 8 or 3 speakers in a 360° cluster module.

MTC-xV* Vertical Array Brackets: Allows vertical end-to-end mounting of up to three Control 23, 25, or 28 speakers.

MTC-xCM* Ceiling Brackets: The curved arm allows installation of Control 23, 25, 28, 29AV or 30 speakers down from a ceiling.

MTC-30MK-WH: Marine grille kit for Control 30 (white only).

SB-2 Installation Brackets: The MTC-SB2W wall/corner bracket allows mounting of the subwoofer onto a wall surface or into a corner.

The MTC-SB2C ceiling bracket enables suspension of the SB-2 from above, projecting downward into the listening area.

PMB-BK and PMB-WH: Control CRV pole-mount bracket for 4-speaker 360° hanging pendant cluster.

Various adaptors for installing via threaded pipe or rod available from third party.

* These models are available in different sizes. Specify speaker model when ordering.

CSS Commercial Series.

CEILING AND SURFACE-MOUNT SPEAKERS



CSS-1S/T 135mm (5.25IN) COMPACT TWO-WAY SPEAKER

The CSS-1S/T is a versatile, compact two-way loudspeaker designed for use on 100V or 70V distributed speaker lines or in 8 ohm direct mode. Aimable wall-mount bracket is included.

- Available in Black.
- Dispersion: 120°x 120° HxV
- Response: 85Hz-18kHz
- Sensitivity: 86dB, D
- Power: 60W 8Ω (10W Tx)

CSS Commercial Series.

PAGING HORNS



CSS-H15/H30 15W/30W PAGING HORNS

The CSS-H15 and H30 paging horns provide excellent voice range clarity. The wide coverage pattern allow the horns to cover larger audience areas, and they are designed for demanding environmental conditions. Available in Grey.

CSS-H15

- Dispersion: 70°x 90° HxV
- Response: 400Hz-7.5kHz
- Sensitivity: 105dB
- Power: 15W 8Ω (15W Tx)
- Environmental: IP-65

CSS-H30

- Dispersion: 50°x 70° HxV
- Response: 380Hz-6kHz
- Sensitivity: 108dB
- Power: 30W 8Ω (30W Tx)
- Environmental: IP-65



Control® 50 Series.

SURFACE-MOUNT SUBWOOFER SATELLITE SYSTEM

The Control 50 Series subwoofer-satellite loudspeaker system provides high fidelity sound in any location where full-range high fidelity foreground/background music is required from a surface-mount system.

The Control 50S/T subwoofer can be utilised with either two of four Control 52 satellite speakers. The Control 50 system is mono. Both the Control 50S/T and Control 52 can be intermixed in systems along with the Control 40 Series in-ceiling models – Control 40CS/T subwoofer and Control 42 satellite speaker – to match the form factor requirements of a wide variety of applications.



CONTROL 52 60mm (2.5IN) SURFACE-MOUNT SATELLITE LOUDSPEAKER

The Control 52 satellite loudspeaker produces superb high fidelity sound via a low distortion 2.5in driver. The included wall bracket allows each speaker to be angled up to 45 degrees off-axis. Available in Black and White.

- Dispersion: 150° Conical
- Response: 140Hz-20kHz
- Sensitivity: 82dB
- Power: 15W 16Ω



CONTROL 50S/T 200mm (8IN) SURFACE-MOUNT SUBWOOFER SYSTEM

The Control 50S/T subwoofer contains a high-power, long excursion, 8in driver which provides extended low frequency response. The Control 50S/T installs quickly with its included two-piece easy-mount wall-bracket. Available in Black and White.

- Response: 32Hz-200Hz
- Sensitivity: 89dB
- Power: 100W 8Ω (80W Tx)



CONTROL C50PACK PACKAGED SURFACE-MOUNT SUBWOOFER-SATELLITE LOUDSPEAKER SYSTEM

The Control 50Pack includes 4x Control 52 satellite speakers and 1x Control 50 subwoofer. Available in Black and White.

- Versatile four satellite speaker system
- Wall mount brackets included
- Response: 32Hz-20kHz



CONTROL 50ST



Control Pro Series. COMPACT INSTALLATION MONITORS

The JBL Control Series speakers offer well balanced sound and exceptional power handling, making these speakers ideal for any installation requiring professional control monitor performance from a compact source.

CONTROL 1 PRO 100mm (5.25IN) TWO-WAY PROFESSIONAL COMPACT LOUDSPEAKER SYSTEM

The Control 1 Pro is a high-performance compact loudspeaker system incorporating monitor-grade, magnetically shielded transducers, a professional crossover network and full-range SonicGuard overload protection. Available in Black.

- Dispersion: 100°x 100° HxV
- Response: 80Hz-20kHz
- Sensitivity: 87dB, D
- Power: 150W 4Ω



CONTROL 2P 100mm (5.25IN) COMPACT POWERED TWO-WAY LOUDSPEAKER SYSTEM

The Control 2P compact powered reference monitor system combines JBL's legendary loudspeaker design with powerful amplification to deliver rich, accurate performance for demanding audio applications. Available in Black.

- Dispersion: 100°x 100° HxV
- Response: 80Hz-20kHz
- Connector: XLR, 1/4in TRS & RCA
- Power Amp: 35W x2



CONTROL 5 125mm (6.5IN) COMPACT PASSIVE TWO-WAY LOUDSPEAKER SYSTEM

The Control 5 is a high-performance, wide range control monitor suitable for use as the primary sound source in a variety of applications. All transducers are magnetically shielded for use in close proximity to video monitors. Available in Black.

- Response: 55Hz-20kHz
- Sensitivity: 89dB, D
- Power: 85W 4Ω



Control CRV Series. ARCHITECTURAL SPEAKERS

The Control CRV brings high design and versatility to commercial applications such as restaurants, retail stores, lounges, theme bars, music cafes, hotels, boardrooms, boutiques, museums, leisure venues, outdoors, upscale lobbies, and other foreground and background music and paging applications that require a fashionable look with superb sound quality.

JBL Control CRV speakers are exceedingly versatile, with multiple installation possibilities. The JBL Control CRV speaker can be wall-mounted aimed straight out from the wall, angled down at a 45° aiming axis, mounted spanning the junction of a wall and ceiling, or spanning the junction of a wall and another wall. At a junction, the unique curved shape of the speaker couples well with both boundary surfaces, forming a dual ground plane configuration which increases the acoustic length of the speaker, providing additional spaciousness to the sound character and increased bass output. In addition, two or three Control CRV speakers can be joined together to create loudspeaker solutions for a wide variety of coverage, appearance and mounting requirements. Using the optional PMB pole-mount bracket, four speakers can be joined together and suspended by a ceiling fan pole to form a cluster module with 360° horizontal coverage.

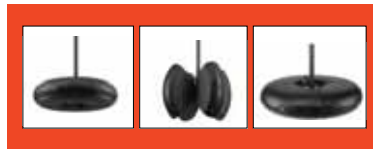

CONTROL CRV CONTEMPORARY CURVED DESIGN LOUDSPEAKER

Control CRV are outdoor capable to IP-34 (per IEC 529), utilising stainless steel screws, professional outdoor-rated screw-down terminals, and screened ports to prevent ingress of pests. Available in Black or White.

- Dispersion: 80°x 105° HxV
- Response: 80Hz-20kHz
- Sensitivity: 89dB, D, WG
- Power: 60W 4Ω (30W Tx)
- Environmental: IP-34

SURFACE MOUNT SPEAKERS

Control HST Series.
ARCHITECTURAL SPEAKERS

The Control HST utilises JBL's patent-pending Hemispherical Soundfield Technology™ to achieve extremely wide coverage of the listening space along with eliminating the primary wall reflection that tends to cause inconsistent sound when speakers are attached to a wall. The wide hemispherical soundfield covers from wall to wall, allowing a single speaker to provide high-fidelity full-range sound to a large listening area. This can reduce the number of speakers needed for covering a space, lowering the overall cost for a sound system.



PENDANT SPEAKERS



Vans Store Gangnam, South Korea

Control 60 Series.
HIGH PERFORMANCE PENDANT LOUSPEAKERS

The Control 60 Series bring renowned JBL sound and outstanding coverage to rooms and venues with open architecture or high-ceilings, while providing superior voice and musical clarity for rooms with difficult acoustics. Easy to install stainless steel hanging hardware is included, featuring redundant suspension cables and UL listed adjustable height hangers. The Control 60 Series pendant speakers are outdoor capable to IP44 (per IEC 529) and pair perfectly with the Control 40 Series ceiling speakers as they share the same sound signature and sonic characteristics.

CONTROL HST
WIDE-COVERAGE SPEAKER WITH 5-1/4IN LF, DUAL TWEETERS AND HST TECHNOLOGY™ LOUSPEAKER

Control HST is ideal for a wide variety of applications, including retail stores, restaurants, corridors, educational facilities, hospitality, music cafes, leisure venues, upscale lobbies, and other background/foreground music and paging applications. The IP-54 outdoor capability also makes it suitable for applications where an outdoor capable speaker is required. The system is capable of handling 100 Watts, and is equipped with a 60W/70V/100V multi-tap transformer. Available in Black or White.



- Dispersion: 180°x 150° HxV
- Response: 50Hz-20kHz
- Sensitivity: 88dB, D, WG
- Power: 75W 8Ω (60W Tx)
- Environmental: IP-54



CONTROL 62P
50MM (2.5IN) ULTRA-COMPACT SATELLITE PENDANT SPEAKER

The Control 62P is great for speech and mid-high music applications (external high pass required) in visually sensitive applications. For full-range applications, up to 4 pieces can be driven from a Control 50S/T or 40CS/T subwoofer. Available in Black or White.

- Dispersion: 140° Conical
- Response: 150Hz-20kHz
- Sensitivity: 84dB
- Power: 15W 16Ω
- Environmental: IP-44



CONTROL 64P/T
100MM (4IN) COMPACT FULL RANGE PENDANT SPEAKER WITH RBI™

The Control 64P/T is a compact full-range, pendant type loudspeaker that provides superb sound reproduction for rooms with open architecture ceilings and other locations where a pendant form factor is desired. Available in Black or White.

- Dispersion: 120° Conical
- Response: 55Hz-20kHz
- Sensitivity: 86dB, D, WG
- Power: 75W 8Ω (60W Tx)
- Environmental: IP-44



CONTROL 65P/T
133MM (5.25IN) COMPACT FULL RANGE PENDANT SPEAKER WITH RBI™

The Control 65P/T incorporates JBL's exclusive RBI Radiation Boundary Integration technology to provide very consistent, wide coverage throughout the listening space. 120° constant directivity broadband pattern control. Available in Black or White.

- Dispersion: 120° Conical
- Response: 55Hz-20kHz
- Sensitivity: 86dB, D, WG
- Power: 75W 8Ω (60W Tx)
- Environmental: IP-44



Control 60 Series.



CONTROL 67P/T 158mm (6.5IN) EXTENDED RANGE PENDANT SPEAKER WITH RBI™

The Control 67P/T incorporates a larger enclosure and high power 6.5in transducer for extended bass output capability. 120° constant directivity broadband pattern control. Available in Black or White.

- Dispersion: 120° Conical
- Response: 58Hz-18kHz
- Sensitivity: 90dB, D, WG
- Power: 75W 8Ω (60W Tx)
- Environmental: IP-44



CONTROL 67HC/T 158mm (6.5IN) HIGH CEILING PENDANT SPEAKER WITH RBI™

The Control 67HC/T has well controlled narrow coverage, ideal for improved voice intelligibility and musical clarity in high-ceiling venues or in rooms with difficult acoustics. Narrow 75° constant directivity broadband pattern control. Available in Black or White.

- Dispersion: 75° Conical
- Response: 75Hz-17kHz
- Sensitivity: 93dB, D, WG
- Power: 75W 8Ω (60W Tx)
- Environmental: IP-44



CONTROL 60PS/T 200mm (8IN) PENDANT SUBWOOFER WITH CROSSOVER

The Control 60 PS/T provides bass and extension, high impact and good transient response for high-fidelity sound systems. Available in Black or White.

- Response: 42Hz-350Hz
- Sensitivity: 89dB
- Power: 150W 8Ω (110W Tx)
- Environmental: IP-44



ACCESSORIES
MTC-PC60: Terminal Cover for C65P/T, C67P/T, C67HC/T & C60PS/T
MTC-PC62: Terminal Cover for C62P

IN-WALL SPEAKERS



Control® Contractor 100 Series.

EASY TO INSTALL WALL SPEAKERS

The Control 100 Speakers are premium in-wall speakers designed for applications where top performance from a loudspeaker with minimal visual impact is required, such as common theatre spaces. The Control 100 Series speakers are voiced similarly to other JBL Control Contractor models, allowing mixing with surface-mount and in-ceiling speakers within a single listening space. The premium sound quality makes these loudspeakers ideal for critical listening environments, yet they are high power and rugged enough to handle venues requiring high-SPL heavy duty-cycle music.

CONTROL 126W/WT PREMIUM IN-WALL LOUDSPEAKER

The Control 126W is a premium in-wall speaker within the JBL Professional Control® Contractor line designed for applications such as foreground music, boardrooms, reception areas, airports, convention centres, cruise ships, retail outlets, restaurants, museums, surround locations, or any critical listening application where top performance from a loudspeaker with minimal visual impact is required. Available in White.

- Response: 38Hz-20kHz
- Sensitivity: 88dB, D
- Power: 50W 8Ω W / 30W Tx WT



CONTROL 128W/WT PREMIUM IN-WALL LOUDSPEAKER

The Control 128W is a premium in-wall speaker within the JBL Professional Control® Contractor line designed for applications such as foreground music, boardrooms, reception areas, airports, convention centres, cruise ships, retail outlets, restaurants, museums, surround locations, or any critical listening application where top performance from a loudspeaker with minimal visual impact is required. Available in White.

- Response: 30Hz-20kHz
- Sensitivity: 90dB, D
- Power: 60W 8Ω W / 50W Tx WT



LANDSCAPE SPEAKERS



Parklane Hotel, Cyprus

GSF Series. GARDEN GROUND-STAKE FULL-RANGE SPEAKERS

Weather-resistant JBL GSF garden ground-stake full-range speakers provide superior fidelity and wide coverage in a range of outdoor commercial applications. Available in hunter green and tan finishes, these speakers are the perfect sound solution for diverse outdoor applications including shopping malls, theme parks, sports venues, hospitality venues, and any application calling for a stylish, robust, great-sounding landscape speaker system.

(includes L-bracket and ground stake)



Control 80 Series. MUSHROOM TYPE OUTDOOR LANDSCAPE LOUDSPEAKERS

The Control 80 Series mushroom-type landscape speakers feature high fidelity performance for outdoor in-ground or on-ground use in applications such as hotels, restaurants, and shopping complexes. A wide frequency response and 360° of horizontal coverage ensure coverage of outdoor spaces with top-quality music and/or intelligible paging. The wiring entrance is via an included water-tight gland nut fitting which can be located in a number of positions on the speaker (installed in the field). A double-chamber seal helps to further protect connections and electrical components for long-term reliability. Colour infused throughout the enclosure case minimises the visual impact of the nicks and scratches that can happen with outdoor speakers. The Control 80 Series are IP-55 rated as per IEC529 (protected against jets of water) and exceeds MILSpec 810 for humidity, salt spray, temperature and UV.



CONTROL 85M TWO-WAY 135mm (5.25IN) COAXIAL MUSHROOM LANDSCAPE SPEAKER

- Dispersion: 360°x 160° HxV
- Response: 55Hz-18kHz
- Sensitivity: 86dB, D, WG
- Power: 45W 8Ω (30W Tx)
- Environmental: IP-56
- Available in Green



CONTROL 89MS LONG-THROW 200mm (8IN) MUSHROOM LANDSCAPE SUBWOOFER

- Dispersion: 360°x160° HxV
- Response: 40Hz-150Hz
- Sensitivity: 87dB
- Power: 150W
- Environmental: IP56
- Available in Green



GSF3 76mm (3IN) GROUND-STAKE LANDSCAPE SPEAKER

- Dispersion: 90° conical
- Response: 74Hz-20kHz
- Sensitivity: 84dB
- Power: 30W
- Environmental: IP66
- Available in Green and Tan



GSF6 152mm (6IN) GROUND-STAKE LANDSCAPE SPEAKER

- Dispersion: 70° conical
- Response: 65Hz-20kHz
- Sensitivity: 87dB
- Power: 50W
- Environmental: IP66
- Available in Green and Tan



CONTROL 88M TWO-WAY 200mm (8IN) COAXIAL MUSHROOM LANDSCAPE SPEAKER

- Dispersion: 360°x 160° HxV
- Response: 47Hz-16kHz
- Sensitivity: 87dB, D, WG
- Power: 100W 8Ω (60W Tx)
- Environmental: IP-56
- Available in Green.

GSB Series.
GARDEN IN-GROUND
SUBWOOFERS

JBL GSB in-ground landscape subwoofers augment the low-frequency performance of JBL GSF full-range landscape speakers to provide rich, full-range sound in lawn and garden areas of hospitality, corporate and retail spaces. Add GSB subwoofers to landscape areas of hotels, shopping complexes, restaurants, public spaces, theme parks or any application that demands legendary JBL sound with deep, rich, powerful bass.



GSB8
203mm (8IN) IN-GROUND
LANDSCAPE SUBWOOFER

- Dispersion: 360°x160° HxV
- Response: 35Hz-130Hz
- Sensitivity: 84dB
- Power: 250W
- Environmental: IP66
- Available in Green and Tan



GSB12
305mm (12IN) IN-GROUND
LANDSCAPE SUBWOOFER

- Dispersion: 360°x160° HxV
- Response: 30Hz-120Hz
- Sensitivity: 85.5dB
- Power: 450W
- Environmental: IP66
- Available in Green and Tan



SOUNDBARS



JBL Pro SoundBar.
COMMERCIAL GRADE ACTIVE SOUNDBAR

The JBL Pro SoundBar PSB-1 is a cost-effective, commercial-grade active soundbar designed specifically for use in applications such as hotel guestrooms, cruise ship staterooms, meeting rooms and public spaces. With an optimised feature set targeting the unique requirements of these applications, the Pro SoundBar reduces the cost and complexity found in consumer-grade soundbars while providing excellent sound quality, security, and reliability.

The all-in-one design of the Pro SoundBar provides full-range sound without the need for a separate subwoofer, providing excellent quality audio while minimising sound transfer to neighboring rooms. For further volume management, the Pro SoundBar offers a 4-position volume limiting switch to control the maximum volume output of the soundbar. The Pro SoundBar supports both fixed and variable source volume for maximum TV compatibility. Controls for the volume switch and source volume selection can be covered by a lockout plate to prevent tampering by anyone other than the support staff.

PSB-1
2.0 CHANNEL COMMERCIAL GRADE SOUNDBAR

- Response: 42Hz-20kHz
- Connector: RCA x2
- Power Amp: 20W x2
- Available in Black



Clarity at Any Level

Better clarity at low levels allows users to hear without increasing volume to intrusive levels.

Front-Facing Speakers

Front-facing speakers offer improved clarity over internal television speakers. TV speakers are typically rear or downward facing, diminishing the quality and volume and increasing sound transference.

Premium Materials

No cloth is used on the speaker grill, making the product easier to clean and maintain and less prone to damage.

Flexible and Easy to Use

The JBL Pro SoundBar is compatible with both fixed volume and variable volume control schemes. Whether the volume is controlled directly at the soundbar or upstream at the TV, the Pro SoundBar is able to support these scenarios, with a single remote controlling the entire system.

This is made possible by the Pro SoundBar's IR Learning feature. In fixed volume scenarios, where the volume is controlled at the soundbar, the Pro SoundBar is able to "learn" the IR pulse of volume up and volume down controls, meaning any remote can be used—programmable or not. This allows guests to use a television remote to adjust the entire system without the need to use a smart remote. No matter the system requirements, the JBL Pro SoundBar offers users a simplified experience.

COLUMN LOUDSPEAKERS



University Of Northampton Waterside, England



Seongsan Methodist Church, Republic Of Korea

JBL CBT Series. LINE ARRAY COLUMN LOUDSPEAKERS

The JBL CBT Series line array columns with Constant Beamwidth Technology break new ground in performance, versatility, and affordability. Designed for venues that would typically use larger point-and-shoot speakers or powered columns, the CBT models incorporate patented technical advancements that allow them to vastly outperform competitive systems, with a level of user-friendliness that virtually eliminates the challenges of delivering great sound. With a slim compact design in fibreglass reinforced ABS enclosures, the CBT Series fits well into virtually any decor. When installed with optional MTC-PC2 panel cover, the CBT series is IP-55 rated (per IEC529).

CBT 50LA-1 50CM TALL LINE ARRAY COLUMN WITH 8X 50mm DRIVERS

The CBT 50LA-1 is the most compact of the models. At 150 watts, it holds its own against larger competitive columns. Response to 80 Hz works well for speech or music. Voicing can be set for music (flat) or speech via a switch. Available in Black or White.

- Dispersion: 150°x 20° HxV
- Response: 80Hz-20kHz
- Sensitivity: 89dB-93dB (Variable modes)
- Power: 100W 8Ω (60W Tx)
- Environmental: IP-55



Also available: Control 50LA-LS – EN54-24 Certified for life safety applications

CBT 100LA-1 100CM TALL LINE ARRAY COLUMN WITH 16X 50mm DRIVERS

The CBT 100LA-1 contains 16x 2in drivers in a slim, compact cabinet, providing excellent pattern control. Vertical coverage is adjustable via a switch and voicing is switchable between music (flat) or speech setting, making this model a great choice for a wide variety of environments. Available in Black or White.

- Dispersion: 150°x 15°/40° HxV
- Response: 80Hz-20kHz
- Sensitivity: 93dB-96dB (Variable modes)
- Power: 200W 8Ω (120W Tx)
- Environmental: IP-55



Also available: Control 100LA-LS – EN54-24 Certified for life safety applications

CBT 200LA-1 200CM TALL LINE ARRAY COLUMN WITH 32X 50mm DRIVERS

With a height of 200cm (6.6 ft), CBT 200LA-1 is the tallest model, providing useful pattern control down to below 200Hz. The top and bottom speaker modules allow individual adjustment of music (flat) speech voicing and vertical pattern settings. Setting in Asymmetrical Progressive Gradient coverage mode (top narrow; bottom broad) sends more sound toward the far listening area versus close for more even SPL near-to-far in the listening space. Available in Black or White.

- Dispersion: 150°x 15°/30° HxV
- Response: 80Hz-20kHz
- Sensitivity: 90dB-95dB (Variable modes)
- Power: 400W 4Ω (240W Tx)
- Environmental: IP-55



CBT 70J-1 TWO-WAY LINE ARRAY COLUMN WITH ASYMMETRICAL VERTICAL COVERAGE

The CBTJ-1 is a two-way speaker with high fidelity and response down to 80Hz, 500W power handling, high sensitivity and high SPL capability. This model provides Asymmetrical Progressive Gradient coverage sending more sound toward the far area of the listening space. Available in Black or White.

- Dispersion: 150°x 25°/45° HxV
- Response: 60Hz-20kHz
- Sensitivity: 92dB-98dB (Variable modes)
- Power: 350W 8Ω
- Environmental: IP-55





CBT 70JE-1
PURPOSE DESIGNED EXTENSION FOR CTB 70J-1

The CTB 70JE-1 extension speaker is purpose-built for use with CBT 70J-1, lengthening the line array to extend the pattern control, extending the bass response, and increasing power handling SPL levels in the LF range. Available in Black or White.

- Response: 45Hz-700Hz
- Sensitivity: 90dB
- Power: 350w 8Ω
- Environmental: IP-55



CBT 1000
CONSTANT BEAMWIDTH TECHNOLOGY™
ADJUSTABLE COVERAGE LINE ARRAY COLUMN

Expanding upon our highly successful Constant Beamwidth Technology™ breakthrough, the CBT 1000 represents the next-generation in pattern control consistency utilising adjustable vertical coverage and a tapered horizontal waveguide to increase the versatility of aiming the coverage of the loudspeaker to more accurately map to the room geometry in a wide variety of listening spaces. Available in Black or White.

- Dispersion Horizontal: 160° to 100° (Asym)
- Dispersion Vertical: 15 Variable Patterns
- Response: 45Hz-20kHz
- Sensitivity: 95dB-102dB (Variable modes)
- Power: 1000W 4Ω
- Environmental: IP55



CBT 1000E
PURPOSE-DESIGNED EXTENSION FOR CBT 1000
LINE ARRAY COLUMN SPEAKER

When connected to a CBT 1000 line array column speaker, the CBT 1000E Extension provides extended bass response, extended pattern control, and increased sound output levels. Available in Black or White.

- Response: 38Hz-650Hz
- Sensitivity: 92dB
- Power: 1000W 8Ω
- Environmental: IP-55

ACCESSORIES

MTG-CBT-70T - Transformer module for CBT 70J-1 or 70J-1 + 70JE-1 array, bolts onto back, 70V/1.00V taps at 120W, 60W, 30W (plus 15W for 70V), gland nuts for water tight seal.

MTG-CBT-6MB1 - Stand Mount Bracket fits all models for portable applications. Note: For stability, CST 70J-E array system and CST 200LA-1 requires larger, heavier-duty stand than JBL SS2-BK.

MTG-CBT-FM1 - Low-profile, close-to-wall mounting bracket for use with CBT 50LA-1, CBT50LA-LS, and CST 1.00LA-1 and CBT 1.00LALS.

MTG-CBT-FM2 - Low-profile, close-to-wall mounting bracket for use with CBT 70J-1 and CST 70J-1/70JE-1 array.

CBT Calculator Software - For designing CBT speakers into projects. Download from jblpro.com website.



JBL COL Series.
SLIM COLUMN LOUDSPEAKERS

The JBL COL Slim Column Loudspeaker product family includes the COL600 (24-Inch 600 mm) and COL800 (32-inch 800 mm). Both provide wide horizontal and narrow vertical coverage, with a built-in 10° down-tilt to the aim, providing optimum coverage for most listening areas while allowing the speaker to be installed flat to the wall. The slim, compact design—winner of international design awards for industrial design excellence—complements virtually any architectural décor. A combination of stylish design and outstanding performance features makes these loudspeakers ideal for a wide variety of applications, such as conference/meeting rooms, lecture halls, retail stores, concourses, transit spaces, fill applications, audio for video, and other applications where slim, compact design and high performance is desired.



COL600
600mm (24in) SLIM COLUMN LOUDSPEAKER

Two 5-inch x 2.25-inch racetrack woofers provide maximum radiating area in a column form factor. The tweeter is located at top of array for less obstructed coverage of the listening space and is aimed at a down angle, allowing down-tilted coverage aim, even with the cabinet flat to the wall. The shallow cabinet depth of 3.7 inches (93 mm) qualifies for ADA (Americans with Disabilities Act) projects when installed with the back of the cabinet flush to the wall. Available in Black or White.†

- (2) 5 x 2.25 inch racetrack woofers and (1) 1 inch tweeter
- 70 Hz – 20 kHz frequency range
- Wide 160° horizontal and focused 110° vertical coverage
- 111 dB peak SPL (105 dB continuous), 2 hrs



COL800
800mm (32in) SLIM COLUMN LOUDSPEAKER

Four 5-inch x 2.25-inch racetrack woofers provide maximum radiating area in a column form factor. Dual tweeters are located at top of the array for less obstructed coverage of the listening space, and they are aimed at a 10° down angle, allowing down-tilted coverage aim, even with the cabinet flat to the wall. The shallow cabinet depth of 3.7 inches (93 mm) qualifies for ADA (Americans with Disabilities Act) projects when installed with the back of the cabinet flush to the wall. Available in Black or White.†

- (4) 5-inch x 2.25-inch racetrack woofers and (2) 0.8-inch tweeters
- 85 Hz – 20 kHz frequency range
- Wide 160° horizontal and focused 60° vertical coverage
- 116 dB peak SPL (110 dB continuous), 2 hrs

BEAM FORMING COLUMNS



The School Of Nichiren's Daijozan Houonji Temple, Japan



Kings Cross Station, UK

JBL Intellivox Series. BEAM FORMING, SELF POWERED LOUDSPEAKER ARRAYS

The JBL Intellivox Series has revolutionised directivity control. If you need to deliver a clear & intelligible message and/or musical clarity in a large reverberant space, then Intellivox is the solution. Thanks to its small cross section and neutral visual design, Intellivox can blend into any environment, allowing sound system designers, architects and acoustic engineers to work together to deliver systems that not only look great but sound great too. Intellivox's pioneering of Beam Steering wasn't the end of the journey, but just the start. Ground-breaking Beam Shaping technology delivers a level of control that is quite simply unmatched. Its superior coverage capabilities once again set a new bench mark within its class. JBL has been constantly improving their DDC (Digital Directivity Control for beam steering) and DDS (Digital Directivity Synthesis for complex beam shaping) technologies, to ensure that the systems continually outpace the competition and are easy to set up and operate.



WHY CHOOSE INTELLIVOX? A GREAT SOUNDING SYSTEM

Quality sound reproduction – delivering the ultimate intelligibility:

- Highly intelligible speech reinforcement
- Natural sound reproduction
- High direct-to-reverberant ratio
- Free from distortion
- Even SPL coverage (The sound level from a properly set up Intellivox unit will be the same, whether the listener is at a distance or close up)

Digital directivity technologies ensure a high ratio of direct sound to reverberant sound which is critical to the intelligibility of any sound system.



A GREAT LOOKING SYSTEM

Architectural Integration – for systems that look great and sound great

- No need for mechanical aiming
- Units can be mounted vertically
- Units can be recessed into surfaces
- Colour matching service available
- Units have a slim and unobtrusive design
- Can be integrated into buildings of all ages and styles.

AN EASY TO INSTALL AND MAINTAIN SYSTEM

- Fewer installation/maintenance points than conventional distributed systems
- Units can be configured from a single control point via an RS-485 network
- A wide range of mounting and cable entry options
- All parts & connections are accessible from the front as well as the rear of the unit making it possible to service the unit in situ
- Most units can be ordered with the electronics module at the top or bottom of the enclosure, allowing additional architectural flexibility.



JFK Terminal 4, USA



Cologne Dome, Germany



Covington Cathedral, USA

A SAFE AND RELIABLE SYSTEM

Emergency sound systems - Intellivox products are designed for use in emergency sound systems:

- Designed to provide reliable operation
- In some cases, Intellivox products are the only way of achieving the required levels of speech intelligibility in a large reverberant space
- All elements of Intellivox products are constantly monitored by the on board RISC processor
- Faults can be reported via the built in failure relay or via the network
- WinControl servers can be supplied to provide fault logging and to interface to external controllers.



Integrated electronics module which combines powerful Digital Signal Processing with multi-channel class D Amplifiers

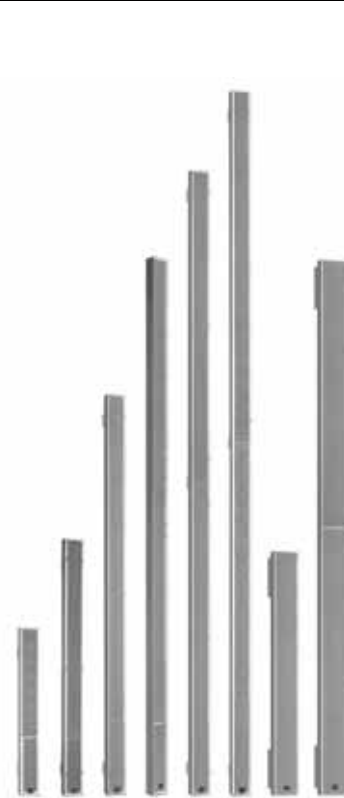

DDA (DIGITAL DIRECTIVITY ANALYSIS)

DDA is a powerful yet intuitive Windows application for accurately predicting the electro-acoustic performance of loudspeaker systems in (semi) open or closed spaces. It includes 3D room acoustic modelling, direct sound simulation as well as statistical prediction of various acoustic parameters.

DDA supports all JBL point source loudspeakers with CLF data and all JBL Intellivox products. Intellivox makes use of JBL's advanced beam shaping (DDS) technologies. From DDA the radiation pattern of JBL Intellivox loudspeaker arrays can be controlled precisely and tailored to the shape and the acoustics of the space. In addition, DDA offers various design tools which reduce design time and help the sound designer to optimise the system performance. For installation and commissioning purposes DDA also generates FIR output filters which can be uploaded to supported DDS-controlled loudspeaker arrays using the JBL WinControl software.

THE JBL PROFESSIONAL INTELLIVOX FAMILY

- | | |
|-----------|-----------|
| DS/DSX500 | DS/DSX280 |
| DS/DSX430 | DS/DSX180 |
| DS/DSX380 | HP-DS170 |
| HP-DS370 | DS115 |

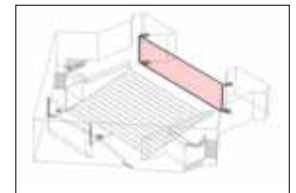

POINT-SOURCE SPEAKERS



Urban Foundry, India

AE APPLICATION ENGINEERED™ SPEAKERS.

ORIGINAL SERIES LOUDSPEAKERS

Imagine if your every need was not only met, but anticipated. The Application Engineered Series does exactly that. The AE Series is a complete line of permanent installation loudspeakers, containing the performance and features that meet the needs of contractors and consultants alike. Incorporating the latest loudspeaker technology, a wide selection of models, high performance features, reliability, and a systems approach, AE Series has a loudspeaker for just about any challenge you might encounter. Optional Weather Protection treatment is available.



AM7212 HIGH-POWER 300mm (12in) TWO-WAY

The AM7212 loudspeaker system is comprised of one 300mm (12in) Differential Drive 2262H woofer and a 2432H high frequency compression driver. The large format PT waveguide provides excellent coverage and is rotatable for use in either the vertical or horizontal orientation. Available in Black or White and WRX/WRX finishes for extreme weather protection.

Available in five models:
 AM7212/64: 60° x 40°
 AM7212/66: 60° x 60°
 AM7212/95: 90° x 50°
 AM7212/00: 100° x 100°
 AM7212/26: 120° x 60°

- Response: 36Hz-20kHz
- Sensitivity: 95dB
- Power: 600W 8Ω (Bi-Amp Switchable)
- Environmental: IP-X3, Optional IP-55 or IP-56
- Suspension: M10 x15



AM7215 HIGH-POWER 380mm (15in) TWO-WAY

The AM7215 loudspeaker system is comprised of one 380mm (15in) Differential Drive 262H woofer and a 2432H high frequency compression driver. The large format PT waveguide provides excellent coverage and is rotatable for use in either the vertical or horizontal orientation. Available in Black or White and WRX/WRX finishes for extreme weather protection.

Available in four models:
 AM7215/64: 60° x 40°
 AM7215/66: 60° x 60°
 AM7215/95: 90° x 50°
 AM7215/26: 120° x 60°

- Response: 34Hz-20kHz
- Sensitivity: 96dB
- Power: 600W 8Ω (Bi-Amp Switchable)
- Environmental: IP-X3, Optional IP-55 or IP-56
- Suspension: M10 x15



AM5212 MEDIUM-POWER 300mm (12in) TWO-WAY

The AM5212 loudspeaker system is comprised of one 300mm (12in) Differential Drive 262H woofer and a 2408H-1 high frequency compression driver. The large format PT waveguide provides excellent coverage and is rotatable for use in either the vertical or horizontal orientation. Available in Black or White and WRX/WRX finishes for extreme weather protection.

Available in five models:
 AM5212/64: 60° x 40°
 AM5212/66: 60° x 60°
 AM5212/95: 90° x 50°
 AM5212/00: 100° x 100°
 AM5212/26: 120° x 60°

- Response: 37Hz-20kHz
- Sensitivity: 96dB
- Power: 300W 8Ω (Bi-Amp Switchable)
- Environmental: IP-X3, Optional IP-55 or IP-56
- Suspension: M10 x15



AE SERIES POINT-SOURCE LOUDSPEAKERS

AE Series loudspeakers are ideal for a wide variety of fixed installation applications including performing arts facilities, theatrical sound design, auditoriums, houses of worship, live music clubs, dance clubs/discotheques, sports facilities and themed entertainment venues.

The special mid-high frequency models can be used without LF reinforcement in voice-only PA and delay-fill applications. The smaller models are ideal in lecture halls and corporate learning centres as well as in delay-fill locations of larger systems.

AE Series models provide a wide variety of building blocks for system designers to achieve just the right solution for any installation.

Within the AE Series there are three power footprint levels. The high output models are found in the 7000 and 6000, medium output power level is found in the 5000 and 4000 with lower output power found in the Compact AC series and Expansion AC series.

Many AE Series speakers offer selectable crossover modes: tri-amp/bi-amp or bi-amp/passive switchable. In addition, AE Series models incorporate sophisticated crossover designs for outstanding sound quality and consistent coverage. To minimise overlap between adjacent frequency bands, steep slopes are utilised in passive crossovers – most are 4th order (24 dB/octave).

This reduces off-axis lobing, providing consistent coverage throughout the crossover region. Conjugate networks are added in some models to fine tune the frequency response for optimum sound quality.



Differential Drive Technology

JBL's exclusive Differential Drive technology is at the core of the AM5212, AM5215, AM7212, AM7215, AM7315, AM7200 and AL7115 as well as the ASB6112, ASB6115, ASB6125, ASB7118 and ASB7128. This technology reduces weight while enhancing all critical performance parameters.



CMCD™ Cone Midrange Compression Drivers

Incorporated into all cone midrange models – patented CMCD technology is more than a simple displacement plug. In addition to providing increased output and lower distortion, this cone-based true compression driver design extends operational bandwidth (both up and down in frequency) to cover the entire vocal range seamlessly, allows for better waveguide pattern control, and improves phase coherency of the midrange signal for clearer, more intelligible audio quality.

Progressive Transition Waveguides

JBL's new patent pending Progressive Transition waveguides represent the latest in horn technology. In addition to providing smooth, low distortion sound, PT waveguides deliver uniform off-axis frequency response to every point within the intended coverage area.



Rosewood Bangkok Hotel, Thailand

AM5215**MEDIUM-POWER 380mm (15in) TWO-WAY**

The AM5215 loudspeaker system is comprised of one 380mm (15in) JBL Differential Drive 2265H-1 woofer and a 2408H-1 high frequency compression driver. The large format PT waveguide provides excellent coverage and is rotatable for use in either the vertical or horizontal orientation. Available in Black, White and WRC/WRX weather resistant finishes.

- Response: 35Hz-20kHz
- Sensitivity: 98dB
- Power: 350W 8Ω (Bi-Amp Switchable)
- Environmental: IP-X3, Optional IP-55 or IP-56
- Suspension: M10 x15

Available in four models:

- AM5215/64: 60° x 40°
- AM5215/66: 60° x 60°
- AM5215/95: 90° x 50°
- AM5215/26: 120° x 60°

**AM7315****HIGH-POWER 380mm (15in) THREE-WAY**

The AM7315 loudspeaker system is comprised of a 380mm (15in) low frequency woofer, one 8in CMCD compression driver, and one 38mm (1.5in) exit compression driver. The multi-band PT mid-high frequency waveguide provides well controlled coverage and is rotatable for cabinet positioning in either horizontal or vertical orientation. Black DuraFlex™ finish. White available upon request.

- Response: 38Hz-20kHz
- Sensitivity: LF 97dB, MHF 108dB
- Power: LF 600W 8Ω, MHF 200W 8Ω (Tri-Amp Switchable)
- Environmental: IP-X3, Optional IP-55 or IP-56
- Suspension: M10 x13

Available in two models:

- AM7315/95: 90° x 50°
- AM7315/64: 60° x 40°



AE Application Engineered™ Subwoofers.

ORIGINAL SERIES SUBWOOFERS

AL7115**HIGH POWER 15in LOW FREQUENCY TRAPEZOIDAL LOUDSPEAKER SYSTEM**

The AL7115 loudspeaker system is comprised of one 15in JBL Differential Drive 2265H woofer in a front-loaded, vented configuration. This model arrays with various AE series mid-high frequency and compact two-way models. Available in Black DuraFlex™ finish. White available on request.

- Cabinet matches AM7315 footprint
- Response: 40Hz-4.2kHz
- Sensitivity: 97dB @ 50Hz-125Hz
- Power: 600W 8Ω
- Environmental: IP-X3, Optional IP-55 or IP-56
- Suspension: M10 x13

**ASB6112****HIGH POWER COMPACT 300mm (12in) SUBWOOFER SYSTEM**

The ASB6112 compact subwoofer system is comprised of one 300mm (12in) JBL Differential Drive 2265H woofer. Black DuraFlex™ finish. White available on request.

- Response: 35Hz-1kHz
- Sensitivity: 98dB
- Power: 700W 8Ω
- Environmental: IP-X3, Optional IP-55 or IP-56
- Suspension: M10 x16

ASB6115**HIGH POWER LIGHTWEIGHT 380mm (15in) SUBWOOFER**

The ASB6115 subwoofer system is comprised of one 380mm (15in) JBL Differential Drive 2265H-1 woofer in a vented, front loaded enclosure. This system is for ground-stacked or suspended applications in combination with other AE series products. Black DuraFlex™ finish. White available on request.

- Response: 32Hz-1kHz
- Sensitivity: 97dB @ 35Hz-400Hz
- Power: 675W 8Ω
- Environmental: IP-X3, Optional IP-55 or IP-56
- Suspension: M10 x16

ASB6125**HIGH POWER LIGHTWEIGHT DUAL 380mm (15in) SUBWOOFER**

The ASB6125 subwoofer system is comprised of two 380mm (15in) JBL Differential Drive 2265H-1 woofer in a vented, front-loaded enclosure. This system is for ground-stacked or suspended applications in combination with other AE series products. Black DuraFlex™ finish. White available on request.

- Response: 32Hz-1kHz
- Sensitivity: 100dB @ 35Hz-400Hz
- Power: 675W 8Ω x2, 1350W 4Ω
- Environmental: IP-X3, Optional IP-55 or IP-56
- Suspension: M10 x16



ASB7118 HIGH POWER ULTRA LONG EXCURSION DUAL 457mm (18in) SUBWOOFER

The ASB7118 high power subwoofer system is comprised of one 18in JBL Differential Drive 2269H ultra long excursion woofer. JBL's exclusive vented gap cooling and ultra robust composite cone ensure extra long life. Black DuraFlex™ finish. Available in White on request.

- Response: 22Hz-1kHz
- Sensitivity: 96dB @ 25Hz-200Hz
- Power: 1200W 8Ω
- Environmental: IP-X3, Optional IP-55 or IP-56
- Suspension: M10 x18



ASB7128 HIGH POWER ULTRA LONG EXCURSION 457mm (18in) SUBWOOFER

The ASB7128 high power subwoofer system is comprised of two 457mm (18in) JBL Differential Drive 2269H ultra long excursion woofers. JBL's exclusive vented gap cooling and ultra robust composite cone ensure extra long life. Black DuraFlex™ finish. Available in White on request.

- Response: 20Hz-1kHz
- Sensitivity: 99dB @ 25Hz-200Hz
- Power: 1200W 8Ω x2, 2400W 4Ω
- Environmental: IP-X3, Optional IP-55 or IP-56
- Suspension: M10 x18



ASB4128 MEDIUM POWER DUAL 457mm (18in) SUBWOOFER

The ASB4128 subwoofer system is comprised of two 18in JBL 2042H woofers in a vented, front-loaded configuration. The deep cabinet allows for extended low frequency bandwidth with minimal frontal profile. Black DuraFlex™ finish. Available in White on request.

- Response: 30Hz-1kHz
- Sensitivity: 103dB @ 30Hz-200Hz
- Power: 300W 8Ω x2, 600W 4Ω
- Environmental: IP-X3, Optional IP-55 or IP-56
- Suspension: M10 x12



ASB6118 HIGH POWER 457mm (18in) SUBWOOFER SYSTEM

The ASB6118 subwoofer system is comprised of one 458mm (18in) JBL 2242H SVG woofer in a vented, front-loaded configuration. Black DuraFlex™ finish. Available in White on request.

- Response: 28Hz-1kHz
- Sensitivity: 98dB @ 30Hz-100Hz
- Power: 800W 8Ω
- Environmental: IP-X3, Optional IP-55 or IP-56
- Suspension: M10 x12



ASB6128 HIGH POWER DUAL 457mm (18in) SUBWOOFER

The ASB6128 subwoofer system is comprised of two 457mm (18in) JBL 2242H SVG woofers in a vented, front-loaded configuration. The deep cabinet allows for extended low frequency bandwidth with minimal frontal profile. Black DuraFlex™ finish. Available in White on request.

- Response: 28Hz-1kHz
- Sensitivity: 102dB @ 30Hz-100Hz
- Power: 800W 8Ω x2, 1600W 4Ω
- Environmental: IP-X3, Optional IP-55 or IP-56
- Suspension: M10 x12



AE Application Engineered™ Expansion Series Loudspeakers.

EXPANSION SERIES LOW COST LOUDSPEAKERS

The AE Expansion series is designed for use in a variety of applications. All models are equipped with multiple M10 attachment points and additional installation-friendly features and utilise a rugged grille design and system appearance suitable for nearly all indoor environments.

The AE Expansion Series includes six 2-way full-range systems and two subwoofer models. The full-range systems include fourteen M10 suspension points and four M8 mounting points for use when a wall mount bracket is required. The subwoofer models include 12 M10 suspension points. All models are available in both black and white textured coatings and are intended for indoor use. The line includes optional U-brackets and a wall mount bracket accessory for all full-range models.

These low-cost systems are a perfect choice for projects including bars, restaurants, clubs, lounges, worship facilities, gymnasiums, retail spaces, and education facilities. Their compact size provides opportunities for system designers to satisfy most architectural requirements.

AC895 TWO-WAY FULL-RANGE LOUDSPEAKER WITH 1 X 203mm (8IN) LF

AC895 is a compact 2-way full-range loudspeaker system comprised of one 203mm (8in) low frequency driver and one 25mm (1in) exit/25mm (1in) voice-coil compression driver. The rotatable PT™ Progressive Transition waveguide provides 90° by 50° coverage in vertical cabinet orientation. Highslope passive crossovers minimise band overlap and well-controlled off axis response. Textured Black paint finish. Available in White on request.

- Dispersion: 90°x 50° HxV
- Response: 70Hz-20kHz
- Sensitivity: 94dB
- Power: 150W 8Ω
- Suspension: M10 x18



AC195 TWO-WAY FULL-RANGE LOUDSPEAKER WITH 1 X 254mm (10IN) LF

AC195 is a compact 2-way full-range loudspeaker system comprised of one 258mm (10in) low frequency driver and one 25mm (1in) exit/35mm (1.5in) voice-coil compression driver. The rotatable PT™ Progressive Transition waveguide provides 90° by 50° coverage in vertical cabinet orientation. Highslope passive crossovers minimise band overlap and well-controlled off axis response. Textured Black paint finish. Available in White on request.

- Dispersion: 90°x 50° HxV
- Response: 68Hz-20kHz
- Sensitivity: 95dB
- Power: 200W 8Ω
- Suspension: M10 x18



AC266

TWO-WAY FULL-RANGE LOUDSPEAKER WITH 1 X 300mm (12IN) LF

A compact 2-way full-range loudspeaker system comprised of one 300mm (12in) low frequency driver and one 25mm (1in) exit/35mm (1.5in) voice-coil compression driver. The horn provides 60° by 60° coverage in vertical and horizontal orientation. High-slope passive crossovers minimise band overlap and well-controlled off axis response. Textured Black paint finish. Available in White on request.

- Dispersion: 60°x 60° HxV
- Response: 63Hz-20kHz
- Sensitivity: 97dB
- Power: 250W 8Ω
- Suspension: M10 x18



AC299

TWO-WAY FULL-RANGE LOUDSPEAKER WITH 1 X 300mm (12IN) LF

A compact 2-way full-range loudspeaker system comprised of one 300mm (12in) low frequency driver and one 25mm (1in) exit/35mm (1.5in) voice-coil compression driver. The horn provides 90° by 90° coverage in vertical and horizontal orientation. High-slope passive crossovers minimise band overlap and well-controlled off axis response. Textured Black paint finish. Available in White on request.

- Dispersion: 90°x 90° HxV
- Response: 63Hz-20kHz
- Sensitivity: 97dB
- Power: 250W 8Ω
- Suspension: M10 x18



AC566

TWO-WAY FULL-RANGE LOUDSPEAKER WITH 1 X 385mm (15IN) LF

A compact 2-way full-range loudspeaker system comprised of one 385mm (15in) low frequency driver and one 25mm (1in) exit/35mm (1.5in) voice-coil compression driver. The horn provides 60° by 60° coverage in vertical and horizontal orientation. High-slope passive crossovers minimise band overlap and well-controlled off axis response. Textured Black paint finish. Available in White on request.

- Dispersion: 60°x 60° HxV
- Response: 60Hz-20kHz
- Sensitivity: 98dB
- Power: 250W 8Ω
- Suspension: M10 x18



AC599

TWO-WAY FULL-RANGE LOUDSPEAKER WITH 1 X 385mm (15IN) LF

A compact 2-way full-range loudspeaker system comprised of one 385mm (15in) low frequency driver and one 25mm (1in) exit/35mm (1.5in) voice-coil compression driver. The horn provides 60° by 60° coverage in vertical and horizontal orientation. High-slope passive crossovers minimise band overlap and well-controlled off axis response. Textured Black paint finish. Available in White on request.

- Dispersion: 90°x 90° HxV
- Response: 60Hz-20kHz
- Sensitivity: 98dB
- Power: 250W 8Ω
- Suspension: M10 x18



AC115S

385mm (15IN) HIGH POWER SUBWOOFER

A high power subwoofer system comprised of one 385mm (15in) low frequency driver in a vented, front-loaded configuration for extended bandwidth. Textured Black paint finish. Available in White on request.

- Response: 32Hz-250Hz
- Sensitivity: 94dB
- Power: 400W 8Ω
- Suspension: M10 x12



AC118S

459mm (18IN) HIGH POWER SUBWOOFER

As per AC115S but 459mm (18in). Textured Black paint finish. Available in White on request.

- Response: 32Hz-250Hz
- Sensitivity: 95dB
- Power: 450W 8Ω
- Suspension: M10 x12



AE Application Engineered™ Compact Loudspeakers.

COMPACT LOUDSPEAKERS

An extension of the industry leading AE Series, the AE Compact family consists of high output, 2-way loudspeaker systems combining flexibility with high fidelity. Ranging from a single 133mm (5.25in) point-and-shoot box to dual 200mm (8in) loudspeaker system that are specifically designed for better serving the needs of both designers and artists alike. The ultra-compact AC15 and AC25 models include a 1in dome tweeter while the AC16, AC26, AC18, and AC28 models feature 1in exit compression drivers providing sonic clarity and crisp detail. The AC18 and AC28 featuring JBL's Progressive Transition™ Rotatable Waveguides, offer the system designer a choice of coverage patterns in either 90° x 50° or 120° x 60°.

AC15

Ultra compact enclosure with one 133mm (5.25in) LF transducer and 90° x 90° waveguide with 25mm dome tweeter. It is equipped with attachment points for a U-bracket and OmniMount® type bracket. Black DuraFlex™ finish. White available upon request.

- Dispersion: 90°x 90° HxV
- Response: 80Hz-20kHz
- Sensitivity: 86dB, D, WG
- Power: 150W 16Ω
- Suspension: M6 x2, M8 x4



AC25

With all the features of the AC15 with two 133mm (5.25in) LF transducers. Black DuraFlex™ finish. White available upon request.

- Dispersion: 90°x 90° HxV
- Response: 80Hz-20kHz
- Sensitivity: 91dB, D, WG
- Power: 225W 16Ω
- Suspension: M6 x4, M8 x4



AC16

Ultra compact enclosure with one 165mm (6.50in) LF transducer and 90° x 90° Progressive Transition™ waveguide with a 25mm exit compression driver. It is equipped with attachment points for a U-bracket and OmniMount® type bracket and standard mount adapter. Black DuraFlex™ finish. White available upon request. WRC/WRX finishes are available for extreme weather protection.

- Dispersion: 90°x 90° HxV
- Response: 55Hz-20kHz
- Sensitivity: 90dB
- Power: 160W 16Ω
- Suspension: M6 x4, M8 x5



AC26

With all the features of the AC16 with two 165mm (6.50in) LF transducers. Black DuraFlex™ finish. White available upon request. WRC/WRX finishes are available for extreme weather protection.

- Dispersion: 90°x 90° HxV
- Response: 55Hz-20kHz
- Sensitivity: 92dB
- Power: 180W 8Ω
- Suspension: M6 x4, M8 x6



AC18/95 & AC18/26

Compact enclosures with one 200mm (8in) LF transducer and a 90° x 50° Progressive Transition Field Rotatable Waveguide with a 25mm (1in) exit compression driver (AC18/95) or 120°x60° Progressive Transition™ Field Rotatable Waveguide with a 25mm (1in) exit compression driver (AC18/26). Equipped with U-bracket attachment points, OmniMount bracket and stand mount adaptor. Black DuraFlex™ finish. White available upon request. WRC/WRX finishes are available for extreme weather protection.

- Dispersion: 90°x 50° & 120°x 60° HxV
- Response: 52Hz-20kHz
- Sensitivity: 92dB
- Power: 250W 8Ω
- Environmental: IP-X3, Optional IP-55 or IP-56
- Suspension: M6 x4, M8 x6



AC28/95 & AC28/26

With all the features of the AC18/95 & AC18/26 with two 200mm (8in) LF transducers. Black DuraFlex™ finish. White available upon request. WRC/WRX finishes are available for extreme weather protection.

- Dispersion: 90°x 50° & 120°x 60° HxV
- Response: 53Hz-20kHz
- Sensitivity: 94dB
- Power: 375W 8Ω
- Environmental: IP-X3, Optional IP-55 or IP-56
- Suspension: M8 x10



All Weather Compact Series.

COMPACT ALL WEATHER

The AWC All Weather Compact models incorporate co-axial drivers for high output, consistent pattern control, extraordinary clarity with speech, and extended frequency response for music, all from very compact enclosures.

These models include minimally audible overload protection, 200 Watt transformers for 70V or 100V distributed systems, and can also be operated 8 ohm direct.



Nagashima Spa Land, Japan

AW All Weather Series.

FULL SIZE ALL WEATHER

ALL WEATHER SERIES: EXCELLENT PROTECTION IN THE HARSHTEST ENVIRONMENTS

The AW full-size models are comprised of the JBL Differential Driver® dual voice coils and dual magnetic gap low frequency 12in and 15in woofers and the 2432H high-frequency 38mm (1.5in) exit, 75mm (3in) voice-coil compression driver. The large format Progressive Transition™ wave-guides provide excellent high-frequency coverage patterns. Waveguides are rotatable so the loudspeaker system can be used in either vertical or horizontal orientation.

Enclosures are constructed of multilayer glass composite and are heavily braced to maximize low-frequency performance. A 14-gauge stainless steel grille, backed with open cell foam and stainless steel mesh, provides excellent protection in the harshest environments. The systems are equipped with a 400W 70/100V transformer. A heavy-duty U-type mounting bracket is included and allows for easy installation on flat surfaces or in 90° corners.



Stade Saint-Symphorien, France

AWC62

COMPACT ALL-WEATHER 165mm (6.5IN) TWO-WAY COAXIAL LOUDSPEAKER

The AWC62 is a compact two-way highly weather-resistant full-range loudspeaker system which is ideal for speech and music fill in a wide variety of applications.

Available in Black or Light Grey.

- Dispersion: 110° Conical
- Response: 70Hz-18kHz
- Sensitivity: 92dB, CD
- Power: 120W 8Ω (120W Tx)
- Environmental: IP-56



AWC82

COMPACT ALL-WEATHER 200mm (8IN) TWO-WAY COAXIAL LOUDSPEAKER

The AWC82 is a compact two-way highly weather-resistant full-range loudspeaker system which is ideal for speech and music fill in a wide variety of applications.

Available in Black or Light Grey.

- Dispersion: 120° Conical
- Response: 80Hz-18kHz
- Sensitivity: 94dB, CD
- Power: 200W 8Ω (200W Tx)
- Environmental: IP-56



AWC129

COMPACT ALL-WEATHER 300mm (12IN) TWO-WAY COAXIAL LOUDSPEAKER

The AWC129 is a compact two-way highly weather-resistant full-range loudspeaker system which is ideal for speech and music fill in a wide variety of applications.

Available in Black or Light Grey.

- Dispersion: 90° Conical
- Response: 55Hz-18kHz
- Sensitivity: 96dB, CD
- Power: 250W 8Ω (200W Tx)
- Environmental: IP-56



AWC159

COMPACT ALL-WEATHER 385mm (15IN) TWO-WAY COAXIAL LOUDSPEAKER

The AWC159 is a compact two-way highly weather-resistant full-range loudspeaker system which is ideal for speech and music fill in a wide variety of applications.

Available in Black or Light Grey.

- Dispersion: 90° Conical
- Response: 52Hz-18kHz
- Sensitivity: 96dB, CD
- Power: 300W 8Ω (300W Tx)
- Environmental: IP-56



AWC15LF

COMPACT ALL-WEATHER 385mm (15IN) LOW FREQUENCY LOUDSPEAKER

The AWC15LF is a compact highly weather resistant loudspeaker for augmenting the low frequency capability of a sound system, and is ideal for use with other AWC full-range loudspeakers. Available in Black or Light Grey.

- Response: 46Hz-2.2kHz
- Sensitivity: 94dB
- Power: 350W 8Ω (300W Tx)
- Environmental: IP-56



AW SERIES ALL WEATHER

- Weather-resistant, all fiberglass enclosure
- Differential Drive® low frequency driver
- U-type mounting bracket included
- Variety of coverage patterns for versatile installation use
- Available in -LS model for EN54-24 compliance
- Available in Black or Light Grey

AW266/AW266-LS
AW295/AW295-LS



AW526/AW526-LS
AW566/AW566-LS
AW595/AW595-LS



AW266
HIGH POWER 300mm (12IN) TWO-WAY FULL-RANGE ALL-WEATHER LOUDSPEAKER

- Dispersion: 60°x 60° HxV
- Response: 40Hz-20kHz
- Sensitivity: 98dB
- Power: 500Ww 8Ω (400W Tx)
- Environmental: IP-55
- Available in Black or Light Grey

Also available: Control AW266-LS – EN54-24 Certified for life safety applications

AW295
HIGH POWER 300mm (12IN) TWO-WAY FULL-RANGE ALL-WEATHER LOUDSPEAKER

- Dispersion: 90°x 50° HxV
- Response: 40Hz-20kHz
- Sensitivity: 98dB
- Power: 500W 8Ω (400W Tx)
- Environmental: IP-55
- Available in Black or Light Grey

Also available: Control AW295-LS – EN54-24 Certified for life safety applications

AW526
HIGH POWER 380mm (15IN) TWO-WAY FULL-RANGE ALL-WEATHER LOUDSPEAKER

- Dispersion: 120°x 60° HxV
- Response: 35Hz-20kHz
- Sensitivity: 98dB
- Power: 600W 8Ω (400W Tx)
- Environmental: IP-55
- Available in Black or Light Grey

Also available: Control AW526-LS – EN54-24 Certified for life safety applications

AW566
HIGH POWER 380mm (15IN) TWO-WAY FULL-RANGE ALL-WEATHER LOUDSPEAKER/ROTATABLE HORN

- Dispersion: 60°x 60° HxV
- Response: 35Hz-20kHz
- Sensitivity: 98dB
- Power: 600W 8Ω (400W Tx)
- Environmental: IP-55
- Available in Black or Light Grey

Also available: Control AW566-LS – EN54-24 Certified for life safety applications

AW595
HIGH POWER 380mm (15IN) TWO-WAY FULL-RANGE ALL-WEATHER LOUDSPEAKER/ROTATABLE HORN

- Dispersion: 90°x 50° HxV
- Response: 35Hz-20kHz
- Sensitivity: 98dB
- Power: 600W 8Ω (400W Tx)
- Environmental: IP-55
- Available in Black or Light Grey

Also available: Control AW595-LS – EN54-24 Certified for life safety applications



CWT Series.
EXTREMELY WIDE-ANGLE COVERAGE LOUDSPEAKER SYSTEM



To provide high quality, full bandwidth sound evenly dispersed across a coverage area greater than 100°, often two speaker systems are mounted and splayed to achieve wider horizontal coverage. But this approach produces interference where the coverage patterns overlap resulting in uneven sound fields and compromised intelligibility.

JBL engineers created an innovative solution to this problem: the CWT128 loudspeaker system featuring CWT Crossfired Waveguide Technology. Drawing on its vast experience in the art and science of loudspeaker technology, JBL continually sets new standards for the audio industry while creating elegant solutions for the challenges that face all sound professionals.

CWT128
HIGH OUTPUT DUAL 200mm (8in) LOUDSPEAKER SYSTEM

The CWT128 is a compact full-range system with dual 209mm (8in) SFG drivers and a 1in exit compression driver. It is designed to provide maximum bandwidth and SPL in a single package system. Available in Black or White.

- Dispersion: 160°x 60° HxV
- Response: 71Hz-20kHz
- Sensitivity: 94dB
- Power: 450W 8Ω (110W Tx)
- Environmental: IP-X3, Optional IP-55 or IP-56
- Suspension: M8 x4, M10 x4

Crossfire Waveguide Technology

At the heart of the CWT128 is the CWT Waveguide featuring a wide coverage pattern designed to provide seamless horizontal coverage across a full 160°. Based on JBL patented technology, the CWT Waveguide is essentially split in half and loaded with two compression drivers facing in different directions. The waveguide delivers wide angle coverage in a single enclosure, exhibiting no interference, and providing remarkable off-axis response. By eliminating multiple sets of speakers that interfere with each other, the overall fidelity of the system is greatly improved, intelligibility is increased, and a more pleasant listening experience is provided for the audience.

PD500 Series.

PRECISION DIRECTIVITY SMALL FORMAT LOUDSPEAKERS 380mm (15in) HORN-LOADED FULL-RANGE LOUDSPEAKER SYSTEM

The PD500 Series is a line of loudspeaker systems consisting of four horn-loaded 380mm (15in) 2-way systems and one dual 380mm (15in) subwoofer. The Series includes horn coverage patterns of 40° x 40°, 60° x 40°, 60° x 60°, and 90° x 50°.

These systems utilise JBL Progressive Transition™ (PT) waveguides coupled with the 2432H 38mm (1.5in) exit, 75mm (3in) voice coil compression driver and the 2031H 380mm (15in) low frequency transducer that features high sensitivity and low power compression for high continuous SPL capability. It is horn-loaded for additional sensitivity and improved pattern control. The 60° x 40° and 90° x 50° waveguides are rotatable allowing all models to be utilised in either vertical or horizontal orientation. The loudspeaker can be operated in either bi-amplified or in full passive mode. All models are available with JBL Professional WRC weather protection and WRX extreme weather protection finishes. All four full-range models are EN54-24 certified when used in full-range (not bi-amp) model.



Horizontal Array



Vertical Stack



Vertical Array

PD544

- Dispersion: 40°x 40° HxV
- Response: 50Hz-20kHz
- Sensitivity: 106dB
- Power: 300W 8Ω (Bi-Amp Switchable)

- Environmental: IP-X3, Optional IP-55 or IP-56
- Suspension: M10 x20
- Available in Black and White

PD566

- Dispersion: 60°x 60° HxV
- Response: 50Hz-20kHz
- Sensitivity: 104dB

- Power: 300W 8Ω (Bi-Amp Switchable)
- Environmental: IP-X3, Optional IP-55 or IP-56
- Suspension: M10 x20
- Available in Black and White

PD564

- Dispersion: 60°x 40° HxV
- Response: 50Hz-20kHz
- Sensitivity: 105dB

- Power: 300W 8Ω (Bi-Amp Switchable)
- Environmental: IP-X3, Optional IP-55 or IP-56
- Suspension: M10 x20
- Available in Black and White

PD595

- Dispersion: 90°x 50° HxV
- Response: 50Hz-20kHz
- Sensitivity: 104dB

- Power: 300W 8Ω (Bi-Amp Switchable)
- Environmental: IP-X3, Optional IP-55 or IP-56
- Suspension: M10 x20
- Available in Black and White

PD525S

HIGH OUTPUT, DUAL 380mm (15in) LOW-FREQUENCY SUBWOOFER LOUDSPEAKER

The PD525S is a high power low frequency loudspeaker comprised of two 380mm (15in) Dual Coil - Dual Gap Differential Drive® low frequency drivers in a front-loaded, vented configuration. The trapezoidal cabinet is fitted with M10 threaded suspension points. Available in Black and White.

- Response: 28Hz-3.8kHz
- Sensitivity: 102dB @ 40Hz-1000Hz
- Power: 500W 8Ω x2, 1000W 4Ω
- Environmental: IP-X3, Optional IP-55 or IP-56
- Suspension: M10 x20



PD6000 Series.

PRECISION DIRECTIVITY MEDIUM FORMAT LOUDSPEAKERS

The PD6000 Series joins JBL's broad lineup of installed sound loudspeakers, complementing the larger PD700 mid-high cabinets with a more compact size and supplementing the smaller AE Series cabinets with higher SPL capability and larger horns for pattern control to a lower frequency. The PD6000 Series loudspeakers deliver high power and constant coverage in a low profile form. Featured across the PD6000 Series, newly developed 24 x 24in PT™ Progressive Transition mid-frequency rotatable waveguides that provide versatility, excellent pattern control with low distortion and extremely natural sound character. This is an evolution of the waveguide technology of the successful JBL Professional Application Engineered™ (AE) install series. Also incorporating sophisticated, steep-slope passive crossover networks minimise band overlap, further enhancing off-axis pattern control. User accessible internal switches allow for a fully active crossover. Optional Weather Protection treatment is available.

PD6200

200MM (8in) HIGH-OUTPUT MID-HIGH LOUDSPEAKER SYSTEM

- Response: 200Hz-18kHz
- Sensitivity: 109dB
- Power: 300W 8Ω (Bi-Amp Switchable)
- Environmental: IP-X3, Optional IP-55 or IP-56
- Suspension: M10 x20
- Black DuraFlex™ finish, available in White on request

- Available models:**
- PD6200/43 (40° x 30°)
 - PD6200/64 (60° x 40°)
 - PD6200/66 (60° x 60°)
 - PD6200/95 (90° x 50°)



PD6212

300mm (12in) FULL-RANGE TWO-WAY LOUDSPEAKER SYSTEM

- Response: 80Hz-18kHz
- Sensitivity: 106dB
- Power: 300W 8Ω (Bi-Amp Switchable)
- Environmental: IP-X3, Optional IP-55 or IP-56
- Suspension: M10 x20
- Black DuraFlex™ finish, available in White on request

- Available models:**
- PD6212/43 (40° x 30°)
 - PD6212/64 (60° x 40°)
 - PD6212/66 (60° x 60°)
 - PD6212/95 (90° x 50°)



PD6322

DUAL 300MM (12in) FULL-RANGE THREE WAY LOUDSPEAKER SYSTEM

- Response: 41Hz-17kHz
- Sensitivity: LF 96dB, MHF 109dB
- Power: LF 1200W 4Ω, MHF 300W 8Ω (Tri-Amp Switchable)
- Environmental: IP-X3, Optional IP-55 or IP-56
- Suspension: M10 x20
- Black DuraFlex™ finish, available in White on request

- Available models:**
- PD6322/43 (40° x 30°)
 - PD6322/64 (60° x 40°)
 - PD6322/66 (60° x 60°)
 - PD6322/95 (90° x 50°)



PD5122

DUAL 300MM (12in) HIGH-POWER LOW FREQUENCY MODULE

The PD5122 is intended for use as a flown or ground supported, high power low frequency module used in conjunction with mid/high only or full-range systems of the PD5000 series. Black DuraFlex™ finish, available in White on request.

- Response: 41Hz-1kHz
- Sensitivity: 96dB @ 60Hz-250Hz
- Power: 600W 8Ω x2, 1200W 4Ω
- Environmental: IP-X3, Optional IP-55 or IP-56
- Suspension: M10 x20



PD5125

DUAL 380MM (15in) HIGH-POWER LOW FREQUENCY MODULE

The PD5125 is a high power low frequency loudspeaker comprised of two 380mm (15in) VGC™ Vented Gap Cooled low frequency drivers in a front-loaded, vented configuration. The trapezoidal cabinet is fitted with M10 threaded suspension points. Black DuraFlex™ finish, available in White on request.

- Response: 37Hz-2.5kHz
- Sensitivity: 103dB @ 50Hz-125Hz
- Power: 600W 8Ω x2, 1200W 4Ω
- Environmental: IP-X3, Optional IP-55 or IP-56
- Suspension: M10 x20



PD700i Series.

PRECISION DIRECTIVITY LARGE FORMAT LOUDSPEAKERS

One of the challenges in large arenas, stadiums, houses of worship and performance spaces is to provide quality sound to every seat with the volume and clarity demanded by today's sporting events, concerts, and special events. The Precision Directivity™ (PD700i and PD700i-215) line of speakers provides exactly that. The PD700i models are greatly improved over their hugely successful predecessors, the PD700 Series, with upgraded mid-frequency and high-frequency components. Two new additions further enhance the capabilities of system designers by adding full-range capabilities by adding two low-frequency drivers to the mid-high models. This allows contractors and consultants to design a fully integrated sound system that solves the audio challenges inherent to these types of large installations. Optional Weather Protection treatment is available.

PD743i

VERY HIGH OUTPUT MID-HIGH LOUDSPEAKER SYSTEM

The PD743i Precision Directivity™ loudspeaker provides high-impact sound reinforcement at throw distances that are beyond the reach of traditional single-driver designs. A single module produces greater than 104dB SPL (continuous) at distances of 50m (165 ft). The PD743i-215 may be used in clusters with other PD family modules or singly as part of a distributed system. Black DuraFlex™ finish, available in White on request.

- Dispersion: 40°x 30° HxV
- Response: 200Hz-19.5kHz
- Sensitivity: 110dB
- Power: 400W 4Ω
- Environmental: IP-X3, Optional IP-55 or IP-56
- Suspension: M10 x32



PD743i-215

VERY HIGH OUTPUT FULL-RANGE LOUDSPEAKER SYSTEM

- Dispersion: 40°x 30° HxV
- Response: 36.5Hz-19.5kHz
- Sensitivity: LF 103dB, MHF 110dB
- Power: LF 1000W 4Ω, MHF 400W 4Ω (Tri-Amp Switchable)
- Environmental: IP-X3, Optional IP-55 or IP-56
- Suspension: M10 x52
- Black DuraFlex™ finish, available in White on request



PD764i

VERY HIGH OUTPUT MID-HIGH LOUDSPEAKER SYSTEM

The PD764i-215 Precision Directivity™ loudspeaker provides high-impact sound reinforcement at throw distances that are beyond the reach of single-driver designs. A single module produces greater than 104dB SPL (continuous) at distances of 50m (165 ft). The PD764i-215 may be used in clusters with other PD family modules or singly as part of a distributed system. Black DuraFlex™ finish, available in White on request.

- Dispersion: 60°x 40° HxV
- Response: 200Hz-19.5kHz
- Sensitivity: 110dB
- Power: 400W 4Ω
- Environmental: IP-X3, Optional IP-55 or IP-56
- Suspension: M10 x28



PD764i-215

VERY HIGH OUTPUT FULL-RANGE LOUDSPEAKER SYSTEM

- Dispersion: 60°x 40° HxV
- Response: 36.5Hz-19.5kHz
- Sensitivity: LF 103dB, MHF 110dB
- Power: LF 1000W 4Ω, MHF 400W 4Ω (Tri-Amp Switchable)
- Environmental: IP-X3, Optional IP-55 or IP-56
- Suspension: M10 x52
- Black DuraFlex™ finish, available in White on request



INSTALLED AUDIO



Nakhon Ratchasima Sports Complex, Thailand

VLAi Series.

LARGE FORMAT VARIABLE LINE ARRAY SPEAKERS

JBL VLAi Series includes six large format horn-loaded modules with three horizontal horn coverage patterns (30°, 60°, and 90°). This horn-loaded modular concept provides the designer additional flexibility to vary the horizontal pattern within a vertical array by incorporating different modules with wider or narrower coverage patterns while still maintaining vertical directivity.

The JBL VLAi Series uses proven JBL components with patented Differential Drive® technology. The mid and high frequency sections are horn-loaded for maximum sensitivity and optimum pattern control. The midrange section features 2169H cone midrange compression drivers with an 8in cone diameter and dual 3in voice coils. The high-frequency section features large format 2432H compression drivers with 3in voice coil. The low-frequency section features JBL's 2265H-1 Differential Drive® dual voice coil dual gap 15in woofer. This woofer features neodymium magnet and ultra-robust cone for extra-long life.

Enclosures feature 16mm (5/8in) exterior grade 12-ply birch plywood. Grills are powder coated 14 gauge acoustically transparent perforated steel. For outdoor applications JBL offers two standard levels of weather resistance. WRX is for outdoor placement where the loudspeaker will be sheltered from direct exposure. WRX is for direct exposure or more extreme environments.



VLA301i

THREE-WAY FULL RANGE LOUDSPEAKER

- Dispersion: 30° x 5° HxV (Varies with array length)
- Response: 39Hz-19kHz
- Sensitivity: LF 99dB, MF 105dB, HF 112dB
- Power: LF 1000W 4Ω, MF 400W 4Ω, HF 160W 16Ω
- Environmental: IP-X3, Optional IP-55 or IP-56
- Suspension: M10 x16
- Available in Black, available in White upon request

VLA301HI

HIGH OUTPUT VERSION

- Dispersion: 30° x 5° HxV (Varies with array length)
- Response: 39Hz-19kHz
- Sensitivity: LF 99dB, MF 112dB, HF 115dB
- Power: LF 1000W 4Ω, MF 550W 8Ω, HF 300W 4Ω
- Environmental: IP-X3, Optional IP-55 or IP-56
- Suspension: M10 x16
- Available in Black, available in White upon request

VLA601i

THREE-WAY FULL RANGE LOUDSPEAKER

- Dispersion: 60° x 8° HxV (Varies with array length)
- Response: 41Hz-20kHz
- Sensitivity: LF 98dB, MF 107dB, HF 111dB
- Power: LF 1000W 4Ω, MF 400W 4Ω, HF 160W 16Ω
- Environmental: IP-X3, Optional IP-55 or IP-56
- Suspension: M10 x16
- Available in Black, available in White upon request

VLA601HI

HIGH OUTPUT VERSION

- Dispersion: 60° x 8° HxV (Varies with array length)
- Response: 41Hz-20kHz
- Sensitivity: LF 99dB, MF 104dB, HF 114dB
- Power: LF 1000W 4Ω, MF 550W 8Ω, HF 300W 4Ω
- Environmental: IP-X3, Optional IP-55 or IP-56
- Suspension: M10 x16
- Available in Black, available in White upon request

VLA901i

THREE-WAY FULL RANGE LOUDSPEAKER

- Dispersion: 90° x 10° HxV (Varies with array length)
- Response: 41Hz-20kHz
- Sensitivity: LF 98dB, MF 106dB, HF 109dB
- Power: LF 1000W 4Ω, MF 400W 4Ω, HF 160W 16Ω
- Environmental: IP-X3, Optional IP-55 or IP-56
- Suspension: M10 x16
- Available in Black, available in White upon request

VLA901HI

HIGH OUTPUT VERSION

- Dispersion: 90° x 10° HxV (Varies with array length)
- Response: 41Hz-20kHz
- Sensitivity: LF 98dB, MF 102dB, HF 110dB
- Power: LF 1000W 4Ω, MF 550W 8Ω, HF 300W 4Ω
- Environmental: IP-X3, Optional IP-55 or IP-56
- Suspension: M10 x16
- Available in Black, available in White upon request

VLA Compact Series Line Array.

SMALL-FORMAT PROFESSIONAL SOUND SYSTEMS

The Variable Line Array (VLA) Compact Series is a line array loudspeaker solution built upon the industry-leading VLA line array solution. Designed to fill the needs of system designers for installations requiring the long-throw capabilities of the VLA in a more compact line array solution, the VLA Compact offers advanced audio capabilities, out-of-the-box IP55-rated weather protection and a fiberglass enclosure for stadiums and arenas and any other project in need of compact, high-powered line arrays.

The modular design concept of the VLA Compact Series offers additional flexibility to vary the horizontal pattern within a vertical array by incorporating different modules with wider or narrower coverage patterns while still maintaining the vertical directivity. This provides the system designer the ability to build line array systems for large venue applications or to design smaller line array systems for use as distributed clusters in arenas, domed stadiums and larger performance spaces, including houses-of-worship.

VLA Compact is designed specifically for permanent installation applications requiring even coverage, high intelligibility and audio levels capable of overcoming crowd noise. As a fundamental design element, VLA Compact Series offers large format horn-loaded modules to provide broad bandwidth horizontal directivity and an increase in sensitivity. The full-range speakers include dual 2261 10in Differential Drive® 3in voice coil low frequency drivers, with 65° and 100° horizontal coverage options available. The VLA-C125S subwoofer has dual 2267H 15in Differential Drive® woofers.



VLA-C265

TWO-WAY FULL RANGE LOUDSPEAKER

The VLA-C265 uses JBL proven technology components. The high frequency section is horn-loaded for maximum sensitivity and optimum pattern control and features three D2415 drivers featuring 1.5in diameter annular diaphragms, 1.5in voice coils, and neodymium motors. The low-frequency section utilizes dual 2261 10in Differential Drive® 3in voice coil drivers.

Enclosures feature multi-layer reinforced fiberglass and steel end-panels. Grilles are zinc plated, powder coated 14-gauge perforated steel with an acoustically transparent black grille cloth backing, a hydrophobic mesh underlayer, and a waterproof rail system.

The rigging system is inherent to the design of the system. Inter-box angles are selected when the array is assembled. Other accessories include a rigging frame, pull-back bar, and a cardioid kit for the sub.

- Available in Black and Grey.
- Dispersion: 65° x 10° HxV (Varies with array length)
- Response: 85Hz-19kHz
- Sensitivity: 102dB
- Power: 400W 8Ω (Bi-Amp Switchable)
- Environmental: IP-55
- Suspension: M10 x8 (array rigging included)

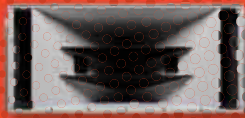
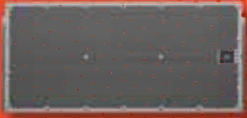

VLA-C2100

TWO-WAY FULL RANGE LOUDSPEAKER WITH 2 X 10IN DIFFERENTIAL DRIVE® LF

The VLA-C2100 uses JBL proven technology components. The high frequency section is horn-loaded for maximum sensitivity and optimum pattern control and features three D2415 drivers featuring 1.5in diameter annular diaphragms, 1.5in voice coils, and neodymium motors. The low-frequency section utilizes dual 2261 10in Differential Drive® 3in voice coil drivers. Enclosures feature multi-layer reinforced fiberglass and steel end-panels. Grilles are zinc plated, powder coated 14-gauge perforated steel with an acoustically transparent Black grille cloth backing, a hydrophobic mesh underlayer, and a waterproof rail system. The rigging system is inherent to the design of the system. Inter-box angles are selected when the array is assembled. Other accessories include a rigging frame, pull-back bar, and a cardioid kit for the sub. Available in Black and Grey.

- Dispersion: 100° x 15° HxV (Varies with array length)
- Response: 86Hz-18kHz
- Sensitivity: 102dB
- Power: 400W 8Ω (Bi-Amp Switchable)
- Environmental: IP-55
- Suspension: M10 x8 (array rigging included)

VLA-C125S

DUAL 380MM (15IN) SUBWOOFER

The VLA-C125S uses JBL proven technology components, featuring dual 380mm (15in) Differential Drive® transducers. Enclosures feature multi-layer reinforced fiberglass and steel end-panels. Grilles are zinc plated, powder coated 14-gauge perforated steel with an acoustically transparent Black grille cloth backing, a hydrophobic mesh underlayer, and a waterproof rail system.

The rigging system is inherent to the design of the system. Inter-box angles are selected when the array is assembled. Other accessories include a rigging frame, pull-back bar, and a cardioid kit. Available in Black and Grey.

- Response: 52Hz-210Hz
- Sensitivity: 98dB
- Power: 800W 8Ω
- Environmental: IP-55
- Suspension: M10 x8 (array rigging included)

VRX900 Series. SMALL-FORMAT PROFESSIONAL SOUND SYSTEMS

Delivering extraordinary power handling, clarity and flexibility, the VRX900 Series Constant Curvature line array loudspeakers feature the hallmark of all JBL products—stunning, legendary JBL sound. Designed to address the growing need for a small-format professional sound system, JBL developed the VRX900 Series for sound rental companies and fixed installations, along with musicians and DJ's looking for the ultimate in performance and portability. Providing the performance of high end line arrays in compact 8- and 12-inch formats, including a powered 12-inch format, VRX900-Series solutions are affordable, flexible and offer outstanding coverage and coherence.

Leveraging technology and components from the JBL VERTEC® Series line arrays, but with a more compact form factor, the VRX900 Series is perfectly suited for use in smaller venues and small to medium sound reinforcement projects. Despite their smaller-scale applications, VRX900 Series Constant Curvature Line Arrays are designed and built to the same high standards as the VERTEC line and uses the same advanced, concert-proven drivers. JBL's VRX900 Series speakers deliver extraordinary power handling, clarity, flexibility and, of course, stunning JBL sound in an attractive, easy to handle and affordable package.



- Constant curvature line array system for an easy to use controlled, coherent coverage pattern.
- High performance, lightweight neodymium Differential Drive Woofers
- Powered by high performance, ultra-compact Crown Class-D amplification
- Simplified rigging and quick connections ensure fast setup and takedown
- Constructed with premium birch plywood and coated in JBL's rugged DuraFlex finish
- VRX Array Tool available for the user to understand and properly deploy the array.

VRX915M 380mm (15in) TWO-WAY FLOOR MONITOR

Dedicated, compact and lightweight 380mm two-way touring class floor monitor using JBL's latest neodymium transducers. Available in Black DuraFlex™.

- Dispersion: 50° x 90° HxV
- Response: 90Hz-20kHz
- Sensitivity: 98dB
- Power: 600W* 8Ω (Bi-Amp Switchable)



VRX915S 380mm (15in) COMPACT HIGH POWER SUSPENDABLE SUBWOOFER

The VRX915S is a compact, high power suspendable subwoofer system containing a 2265G-1 neodymium magnet, patented Differential Drive®, 15in woofer in a front-loaded, vented enclosure. Available in Black DuraFlex™.

- Arrays with VRX928LA
- Response: 35Hz-250Hz
- Sensitivity: 91dB
- Power: 800W* 4Ω
- Suspension: Integrated array rigging on M10 x8. M20 pole socket



VRX928LA 200mm (8in) TWO-WAY COMPACT LINE ARRAY SPEAKER SYSTEM

Designed for use in arrays of up to six units. Ideal when line array performance is needed but the venue size doesn't call for the very long-throw characteristics of the larger VRX932LA. Available in Black DuraFlex™.

- Dispersion: 100° x 15° HxV (Varies with array length)
- Response: 70Hz-20kHz
- Sensitivity: 90dB
- Power: 400W* 8Ω (Bi-Amp Switchable)
- Suspension: Integrated array rigging on M10 x4 Dual angle pole socket



VRX932LA-1 300mm (12in) TWO-WAY COMPACT LINE ARRAY SPEAKER SYSTEM

Lightweight compact and designed for use in arrays of up to six units. Available in Black DuraFlex™.

- Dispersion: 100° x 15° HxV (Varies with array length)
- Response: 57Hz-20kHz
- Sensitivity: 95dB
- Power: 800Ww* 8Ω (Bi-Amp Switchable)
- Suspension: Integrated array rigging on M10 x4. Dual angle pole socket



VRX932LAP 300mm (12in) TWO-WAY COMPACT LINE ARRAY SPEAKER SYSTEM

Powered version of VRX932LA-1. Available in Black DuraFlex™.

- Dispersion: 100° x 15° HxV (Varies with array length)
- Response: 57Hz-20kHz
- Power: 1750-watts Peak, 875-watts Continuous, Class D
- Suspension: Integrated array rigging on M10 x4. Dual angle pole socket



VRX918S 457mm (18in) COMPACT HIGH POWER SUSPENDABLE SUBWOOFER

The VRX918S is a compact, high power suspendable subwoofer system containing a 2268H neodymium magnet, patented Differential Drive®, 18in woofer in a front-loaded, vented enclosure. Available in Black DuraFlex™.

- Arrays with VRX932LA
- Response: 31Hz-250Hz
- Sensitivity: 95dB
- Power: 800W* 8Ω
- Suspension: Integrated array rigging on M10 x4 M20 pole socket



VRX918SP 457mm (18in) POWERED HIGH POWER SUSPENDABLE SUBWOOFER

The VRX918SP is a powered, suspendable subwoofer system containing a 2268FF neodymium magnet, patented Differential Drive®, 18in woofer in a front-loaded, vented enclosure. The VRX918SP was designed specifically for use in arrays with the VRX932LAP Line Array speaker and VRX-AF Array Frame. In addition it may also be used in arrays consisting entirely of VRX918SP subwoofers. Available in Black DuraFlex™.

*2 Hour IEC with 6dB Crest.

- Arrays with VRX932LAP
- Response: 31Hz-250Hz
- Power: 1500W Peak, 750W Continuous, Class D
- Suspension: Integrated array rigging on M10 x4. M20 pole socket



VTX A-Series

SCALABLE, SMART AND EFFICIENT

The VTX A-Series was designed from scratch to address not only audio performance, but the full scope of challenges faced by tour sound professionals, rental companies, FOH engineers and live production crews. Want unparalleled performance, sensitivity and coverage? JBL's proprietary transducer technology and high-frequency waveguides deliver. Want streamlined deployment and setup? A patented JBL rigging mechanism and redesigned suspension system make it happen.

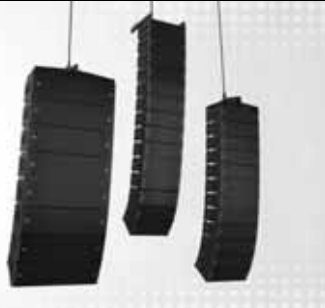

VTX A6

SUB-COMPACT DUAL 6.5-INCH LINE ARRAY ELEMENT

The A6, JBL's smallest VTX line array product to date, brings flagship VTX A-Series performance to a subcompact form factor. The fully passive, two-way line array element is a versatile solution for small to mid-size rental houses, corporate events, theaters, clubs, houses of worship or anyone who demands superior sound reinforcement.

- 3-inch polymer annular-diaphragm compression driver and integrated waveguide
- Custom 6.5-inch woofers
- (RBI) horn design provides 120° horizontal dispersion
- Efficient passive crossover network



VTX A8

DUAL 8-INCH COMPACT LINE ARRAY LOUDSPEAKER

The A8 combines two 8in woofers, four 3.5in midrange drivers and two 2in high-frequency drivers in a single low-profile cabinet. Proprietary double-flared low-frequency ports, precisely calculated for greater low-frequency performance extend the usable operating range down to 49Hz.

- 3-way bi-amp design
- Differential Drive™ woofers and Slip Stream™ ports
- Radiation Boundary Integrator® (RBI) design
- Built-in MF/HF passive network
- Compact, lightweight design



VTX A12 & A12W

DUAL 12-INCH LINE ARRAY LOUDSPEAKER

VTX A12 was designed from scratch to address the unique challenges of rental companies, FOH engineers and tour sound production crews. Next-generation JBL transducer technology and a high-frequency waveguide design deliver unmatched performance, sensitivity and coverage.

- Innovative HF section
- Redesigned Radiation Boundary Integrator® (RBI) design
- Next Generation LF section



Inside The Innovations

For VTX A-Series, next-generation transducers were engineered from the ground up by JBL for linear performance, high output and consistent coverage. Together, their custom-designed low-, mid-, and high-frequency sections deliver the highest output per weight in their class, with improved low-frequency extension and controlled directivity that ranges from 90–120 degrees. Physical design refinements integrate more drivers into smaller, lighter cabinets for reduced overall system weight and truck-friendly dimensions. A revolutionary auto-locking rigging and suspension system speeds deployment time. It all adds up to big-system-JBL sound in our most convenient and comprehensive offering to date.

Advanced Speaker Components

- High Frequency—Combines the HF phasing plug and waveguide in a single part
- Radiation Boundary Integrator—Integrates mid-frequency woofers with the high-frequency horn
- Low Frequency—A lightweight neodymium low-frequency woofer
- Suspension System—Patented auto-locking mechanism
- Grill Design—Minimizes exposed components



Smooth, Even Coverage In Any System Configuration

VTX A-Series speakers adhere tightly to their dispersion patterns, which keeps the sound where you want it: off the stage and in the audience. All four models feature the same HF compression driver, waveguide technology and other HF components, ensuring uniform, consistent voicing and coverage and providing the flexibility to design systems that match the needs of any listening environment.



Innovative Rigging And Transport

To facilitate fast deployment, array elements are stacked four per vertical transporter (VT) cart in a 10-degree collapsed position. A patented auto-locking mechanism lets users select angles while components are on the ground; once the system is suspended, the mechanism automatically locks cabinet angles in designated positions. Angles can be set in increments as low as 0.25 degrees simply by pulling and placing a pin—it's that easy.

Advanced High Frequency Section

The high-frequency (HF) section found in the VTX A-Series combines the HF phasing plug and waveguide into a single part, which increases sensitivity and provides better tolerances while reducing distortion and overall weight.

Acoustically Integrated Mids And Highs

VTX A-Series features JBL's patented Radiation Boundary Integrator (RBI), which integrates mid-frequency drivers in the high-frequency waveguides for a seamless transition across each band and maximum transducer density.

Superior Low Frequency Extension

The VTX A-Series delivers big low-frequency performance thanks to its custom lightweight, neodymium low-frequency woofers. Transducer design is based around JBL's Differential Drive technology, a dual-voicecoil, dual-gap configuration that maximizes excursion, power handling and sensitivity in a compact footprint. The resulting sound quality is extraordinarily transparent, even at very high SPLs. Coupled with flared, exponential low-frequency ports, A-Series' new LF drivers provide low-frequency extension that's unmatched in their class.

VTX V-Series. PERFORMANCE LINE ARRAY SYSTEM

Of all the achievements JBL has made over the years, the VTX V-Series stands as a milestone in the practical application of creative engineering because of their high levels of performance, system integration and user-friendliness—and years of high profile tours, festivals, and installations can attest to that fact. The V-Series evolved from JBL's continued effort to deliver more powerful, more compact, lightweight and flexible sound reinforcement systems for portable and fixed-venue system operators alike.



VTX V25-II FULL SIZE 3-WAY LINE ARRAY

The VTX V25-II includes a new 4th generation waveguide which improves long throw performance, wavefront control, and is an improved power match for the Crown IT4x3500HD. The transducer complement for VTX V25-II is two 2000W 15in Differential Drive® woofers mounted in die cast aluminum baffles, four 8in Differential Drive midrange transducers firing through a patented (RBI Radiation Boundary Integrator®), and three revolutionary D2 Dual-Diaphragm Dual-Voice-Coil Compression Drivers loaded onto the newly designed waveguide.



- D2 Dual Diaphragm, Dual Voice Coil Compression Drive
- RBI (Radiation Boundary Integrator®)
- Patented JBL S.A.F.E.™ Suspension System
- Aluminum front baffles

Available models:
VTX V25-II
 Full Size 3-Way Line Array with Fixed Angle ASM Suspension
VTX V25-II-CS
 Full Size 3-Way Line Array with Compression Suspension System

VTX V20 THREE-WAY LINE ARRAY ELEMENT

VTX V20 features the advanced technology and extraordinary performance of the groundbreaking VTX V25 in a smaller format, high power density 3-way system complemented by a new suspension system that provides efficient transport, fast setup and precise configuration. All VTX V20 components have been specifically engineered to provide stable 105 degree horizontal coverage and effective line source array coupling in the vertical plane while delivering linear, transparent sound up to surprisingly high output levels for its diminutive size.



- Differential Drive Technology
- Small format D2 Dual Compression Driver
- ASM Suspension System



The Realization Of Engineering Excellence

At the heart of VTX is the D2 Dual Driver, a revolutionary device developed by JBL that dramatically improves the sound and performance of high frequencies. Merging two compression drivers into a single, compact transducer with a single acoustical output, the D2 Dual Driver utilizes two voice coils, each with its own lightweight, polymer, annular diaphragm, its own magnet assembly, and its own specialized phasing plug. Instead of the large and 'heavy' single voice coil metal dome diaphragm of conventional compression drivers, D2 is driven by two light but strong voice coils, two motive 'forces' instead of one, acoustically connected to a single exit chamber. The two annular polymer diaphragms have the same radiating area as a conventional single dome, and overall output and power handling are dramatically increased due to the lower moving mass and enhanced heat transfer obtained with two separate voice coils.

The result is a compact compression driver with dramatically improved efficiency, power handling, smoother, extended high frequency response and significantly lower levels of nonlinear distortion. Well-validated by objective measurements, D2's performance has also gone through exhaustive subjective listening tests, demonstrating its superior sound quality compared to traditional metallic, mono structure drivers. D2 provides an extreme output advantage over conventional systems with significantly higher array power density. Compared to a conventional system, the D2 has double the number of voice coils and more than double the power handling, but with a 30% reduction in weight. This results in a dramatic increase in pure high frequency sound pressure levels in the same physical footprint.



A simple formula for success in modern audio technology is to employ the best engineers using the best methodology and tools, and always develop from the ground up—a formula that JBL has perfected for over 70 years. The result is a prolific list of audio achievements, groundbreaking technologies, revolutionary advances in the art and science of professional audio, patents and awards—many of them. It's a journey that is legendary worldwide and has positioned JBL as the world leader in professional audio.



Powerful Mid-Range 2169H 8in Transducers

The low distortion, high output design of the 2169H 8in mid-range transducers ensures superb fidelity and articulation for critical mid-range frequencies. The VTX V25 system's mid-range drivers employ JBL's exclusive Differential Drive technology for lower weight and higher output. The highly efficient cooling characteristics of the mid-range drivers ensure lower operating temperatures, greatly improved power compression characteristics, dynamic headroom and lower harmonic distortion.

Powerful Low Frequency 2267H 15in And 2269H 18in Transducers

The 2267H was specifically designed for VTX V25 and has the same motorstructure as employed in the 2269H 18in transducer featured in both G28 and S28 subwoofers. The result? Four-inch diameter, dual voice coil, dual magnet transducers with industry-leading AES 2 hr power handling of 2000 Watts. Combined with uncompromised Crown power amplification, VTX V25 low section output is unequalled in its class and G28, S28 subwoofers provide a solid foundation for high impact, very low frequency reproduction.



S.A.F.E.™ Suspension

VTX's patented S.A.F.E. suspension system is streamlined for speed and efficiency with improved hardware for faster setup with fewer pinning operations and greater security. A custom-designed protective cover and dolly makes transport easy and the suspension process fast, efficient and safe. Vertical Transporters are also available allowing for transport of four V25 enclosures or three S28 enclosures in either front-firing or cardioid mode.

All suspension hardware is integrated into the enclosure and strategically positioned for fast and secure operation. Front flip hinges and captive rear hinge bars utilizing a unique Angle Stop Mechanism (ASM) allow for efficient assembly that is not only secure, but antirattle. Also included is provision for mounting a Laser Sighting Module accessory for greater ease and precision in array focus and system tuning.

VTX F Series.

STUDIO MONITOR SOUND QUALITY

VTX F Series delivers studio monitor sound quality in a line of premium two-way multipurpose cabinets featuring point and shoot flexibility, uncompromised sound quality and the patented D2 Dual Diaphragm Dual Driver used in the VTX V25-II and M2 Studio Reference Monitor. VTX F Series features a premium transducer upgrade of a tried-and-tested design that has always delivered for their most demanding clients.



Nz Sound Reinforcement At Bay Dreams Festival, New Zealand

VTX F18 S

458MM (18IN) COMPACT SUBWOOFER



The VTX F series is a line of multi-purpose loudspeakers designed to give sound production companies a variety of flexible options for deploying high-quality audio, either as a stand-alone FOH system, a satellite and subwoofer system (with companion VTX F18S), or on-stage floor monitor and fill speaker.

- Dispersion: 50°x 90° HxV
- Response: 60Hz-20kHz
- Sensitivity: 98dB
- Power: 600W* 8Ω (Bi-Amp Switchable)

VTX F12

305mm (12in) BI-AMPLIFIED 2-WAY SYSTEM

The VTX F series is a line of multi-purpose loudspeakers designed to give sound production companies a variety of flexible options for deploying high-quality audio, either as a stand-alone FOH system, a satellite and subwoofer system (with companion VTX F18S), or on-stage floor monitor and fill speaker.

- Dispersion: 90°x50° (vertical orientation)
- Response: 51Hz-21.5kHz
- Max SPL: LF: 138dB; HF: 137dB
- Power: LF: 1,000W continuous (AES)/2 hour
- HF: 200W continuous (AES)/2 hour



VTX M Series.

PREMIUM TOUR-READY MONITORS

VTX M Series monitors feature high performance differential drive woofers and the large-format D2 dual-diaphragm dual voice-coil high frequency driver. The option of Single-Channel (Passive) or Dual-Channel (Bi-Amp) operation modes comes standard, allowing the user to choose the right option for the application, with no compromise in output power or performance.



VTX F15

380mm (15in) BI-AMPLIFIED 2-WAY SYSTEM

The VTX F series is a line of multi-purpose loudspeakers designed to give sound production companies a variety of flexible options for deploying high-quality audio, either as a stand-alone FOH system, a satellite and subwoofer system (with companion VTX F18S), or on-stage floor monitor and fill speaker.

- Dispersion: 90°x50° (vertical orientation)
- Response: 43Hz-21.5kHz
- Max SPL: LF: 134dB; HF: 137dB
- Power: LF: 1,000W continuous (AES)/2 hour
- HF: 200W continuous (AES)/2 hour



VTX F35

380mm (15in) HIGH PERFORMANCE DUAL 3-WAY LOUSPEAKER

The F35 is the go-to choice for customers needing high-power side-fills, mains speakers, or a high-performance point-source solution to complement to larger VTX systems. This system has an exceptional power-to-weight ratio thanks to its lightweight, Differential Drive 15in and 8in transducers, and benefits from proven JBL technologies, including a multi-band Progressive Transition Waveguide and the high-performance D2 high-frequency driver.

- Dispersion: 90°x50° HxV
- Response: 39Hz-18kHz
- Max SPL: 143dB
- Power: LF: 2x800W continuous (IEC)/100 hour
- MF: 270W continuous (IEC)/100 hour
- HF: 100W continuous (IEC)/100 hour



SPECIFICATIONS		
Model	VTX M20	VTX M22
Coverage Pattern	60°H x 60°V	60°H x 60°V
Maximum Peak Output*	138 dB	138dB
System Power**	1250 W Continuous (IEC / 100 hour) LF: 1250 W Continuous (IEC / 100 hour) HF: 100 W Continuous (IEC / 100 hour)	1500 W Continuous (IEC / 100 hour) LF: 1500 W Continuous (IEC / 100 hour) HF: 100 W Continuous (IEC / 100 hour)
Frequency Range (10 dB)	65 Hz - 19.5 kHz	45 Hz - 19.5 kHz
Nominal Impedance Single Channel (Passive)	4-ohm	4-ohm
Nominal Impedance Dual Channel (Bi-Amp)	LF: 4-ohm HF: 8-ohm	LF: 4-ohm HF: 8-ohm
Transducers	LF: 2 x 10in HF: 1 x Dual-3in	LF: 2 x 12in HF: 1 x Dual-3in
Amplification	Crown iTech HD	Crown iTech HD
Dimensions (mm,In)	342.9 mm x 575.0 mm x 515.3 mm (13.5 in x 22.6 in x 20.3 in)	380.1 mm x 670.8 mm x 555.0 mm (15.0 in x 26.4 in x 21.8 in)



VTX M20
DUAL 10-INCH
PROFESSIONAL STAGE MONITOR



VTX M22
DUAL 12-INCH
PROFESSIONAL STAGE MONITOR

*Peak, unweighted SPL, measured under half-space conditions at 1 meter using broadband pink noise with a 10dB crest factor and specified preset.

**IEC Standard: IEO shaped noise with 6dB crest factor based on Nominal Impedance and a duration of 100 hours

VTX Subwoofer Series.

UNCOMPROMISED LOW-FREQUENCY PERFORMANCE

Boasting JBL's legendary subwoofer technology innovations, VTX Subwoofers include models that feature Differential Drive® transducers that integrate a dual voice coil, dual-gap design, neodymium magnets, and carbon-fiber-based cones. JBL Slip Stream™ low-frequency port technology include proprietary double-flared ports, precision-engineered for greater low frequency extension and reduced port noise.



COACHELLA VALLEY MUSIC AND ARTS FESTIVAL, INDIO, CALIFORNIA

VTX B15 380mm (15in) COMPACT ARRAYABLE SUBWOOFER

The VTX B15 Compact Arrayable 15-inch Subwoofer extends the low-end performance of VTX full-range sound-reinforcement systems, including the VTX A6 Subcompact Dual 6.5-inch Line Array Element. The B15 is a versatile solution for production companies, touring acts, rental houses, theaters, houses of worship or anyone who demands superior sound reinforcement when space is at a premium.

- 2285H 15-inch woofer
- SlipStream double-flared ports
- Differential Drive dual-voicecoil
- Rugged, exterior-grade birch plywood
- Neutrik STX speakON NL4 connectors



VTX B18 457mm (18in) SINGLE SUBWOOFER

The VTX B18 features JBL's new 2288H 18in woofer, engineered for improved linearity, increased sensitivity and extra-long excursion. The 2288H is based on JBL's Differential Drive, dual voice coil, dual-gap technology, which delivers better heat dissipation, lower power compression and wider dynamic range than conventional single-coil designs. The B18 incorporates JBL's patented Slip Stream™ double-flared exponential low-frequency port design to improve airflow and reduce audible turbulence, even at maximum excursion.

- 2228 transducer
- SlipStream double-flared ports
- Built-in, easy to use, spring-loaded rigging system
- Front and rear NL4 connectors
- Compact design



VTX B28 457mm (18in) ARRAYABLE DUAL SUBWOOFER

The B28 boasts JBL Differential Drive transducers, an exclusive port design, and the same industrial design found in JBL's VTX A-Series products. It is equally ideal flown or ground stacked, in omnidirectional or cardioid configurations. Simple and fast rigging, a selection of accessories, and software support make the B28 an exceptional choice for rental, AV, and touring companies, as well as in high-end fixed installations.

- Linear bass response down to 25 Hz
- JBL Differential Drive woofers
- Large double-flared port
- 2-point spring-loaded rigging system
- FEA-optimized enclosure



VTX S25 380mm (15in) SUSPENDABLE, CARDIOID-ARRAYABLE, DUAL SUBWOOFER

The dual 15in, cardioid-arrayable S25 subwoofer provides industry-leading very low frequency output and can be integrated with V20 with tremendous versatility, either ground-stacked or suspended in mixed arrays or standalone.

- Differential Drive Technology
- V5 System Integration



VTX S28 457mm (18in) SUSPENDABLE DUAL SUBWOOFER

VTX series dual 18in subwoofers employ two 2269H 18in transducers featuring Differential Drive technology with two voice coils, two neodymium magnets and extremely high peak-to-peak excursion capabilities to deliver extended very low frequency performance.

- 2269H Differential Drive®
- Reverse-Cardioid Arrayable
- Compatible with VTX V25 suspension
- BSS® Audio OmniDriveHD V5 Processing



SRX900 Series. OUTSTANDING SONIC PERFORMANCE

The SRX900 Series' outstanding sonic performance is based on time-tested JBL technologies. Custom-engineered and manufactured, high-power-handling transducers deliver extremely low distortion, high fidelity and class-leading output. Precision waveguides provide accurate pattern control for intelligibility and definition that are unmatched in this category. A full suite of user-configurable DSP and design-and-management software tools provides hands-on control from a computer or mobile device, making design, deployment and control a breeze. SRX900's cabinet architecture is thoughtfully engineered for easy handling, fast rigging, minimal space displacement and streamlined transport.



SEAMLESS SOFTWARE CONTROL

The SRX900 Series' unified software suite lets users manage system design, control and deployment functions on Windows, macOS, and iOS. Use JBL LAC-3 simulation software for system design and the new, cross-platform JBL Performance application for system management; transfer rigging information via the Array Link iOS/Android companion app. A rear-panel LCD screen provides full on-speaker access to control features, making it easy for users to troubleshoot large systems or configure small systems right onscreen.



VERSATILE, SCALABLE AND AFFORDABLE

The SRX900 Series offers a complete system solution, including speakers, subwoofers and accessories that support a variety of configurations and simplify storage, transport and rigging. Because systems are scalable, it's easy to start with a small investment and add components over time. SRX900 products are designed to work seamlessly with other JBL touring sound products, thanks to common voicing targets and phase characteristics.



FAST, SAFE, EASY RIGGING

FAST, SAFE, EASY RIGGING

SRX900 Series systems are designed for both portable and installed applications and can be deployed in a variety of configurations, from pole-mounted to ground-stacked to flown arrays of up to 16 cabinets. A three-point rigging system, adapted from VTX technologies, makes suspending systems safe and easy, regardless of system size or user experience level. Set splay angles on the ground, cabinets lock into place as the system is lifted. The rear rigging spine serves as an additional heatsink for added cooling. Available accessories include array frames, base plates, pole-mount and truss-clamp adapters, cases, carts and covers.

SRX906LA DUAL 165mm (6.5IN) POWERED LINE ARRAY LOUDSPEAKER

The SRX906LA is a compact, two-way, active line array element that can cover a variety of small- to mid-sized applications, including rental houses, touring artists, DJs, and installations. Built-in DSP and amplification offer a plug and play experience while providing consistency and optimum performance anywhere in the world.

- High performance, high-density system
- High-power-handling transducers
- Built-in, passively cooled Class D amplification
- Dual Ethernet ports



SRX910LA DUAL 254mm (10IN) POWERED LINE ARRAY LOUDSPEAKER

The SRX910LA is a two-way active line array element that can cover a variety of mid- to large-sized applications, including rental houses, touring artists, DJs, and installations. Built-in DSP and amplification offer a plug and play experience while providing consistency and optimum performance anywhere in the world.

- High performance, high-density system
- High-power-handling transducers
- Built-in, passively cooled Class D amplification
- Dual Ethernet ports

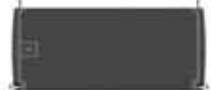

SRX918S 203mm (18IN) POWERED SUBWOOFER

The SRX918S is a single 18-inch active subwoofer designed to complement SRX900 Series full-range sound reinforcement systems. The subwoofer houses a JBL 2279-1 18-inch woofer featuring Differential Drive® – JBL's dual voice coil, dual gap technology – to deliver better heat dissipation, lower power compression, and wider dynamic range than conventional single-coil designs.

- High performance, high-density system
- High-power-handling transducers
- Built-in, passively cooled Class D amplification
- Dual Ethernet ports



SRX928S DUAL 203mm (18IN) POWERED SUBWOOFER

The SRX928S is a dual 18-inch active subwoofer designed to complement SRX900 full-range sound reinforcement systems. The subwoofer houses two JBL 2279-1 18-inch woofers, featuring Differential Drive® – JBL's dual voice coil, dual gap technology – to deliver better heat dissipation, lower power compression, and wider dynamic range than conventional single-coil designs.

- High performance, high-density system
- High-power-handling transducers
- Built-in, passively cooled Class D amplification
- Dual Ethernet ports



LIVE PORTABLE PA SPEAKERS

The road to the top is long and difficult. You need a PA system that is built to take it. Before you even plug it in, the EON800 endures JBL's legendary testing protocol, including 100 hours of playback at full power, and extreme environmental and drop tests. Sturdy cabinet materials, heavy-gauge grilles, and genuine JBL transducers ensure that the EON800 delivers exceptional sound for the long haul, gig after gig. Plus, integrated Bluetooth capability gives you convenient and simple wireless control.



Nam Nghi Resort's Rock Island Club, Vietnam

PRX400 Series.

PORTABLE PASSIVE LOUDSPEAKERS

PRX400 passive speakers were designed to provide the sensitivity, frequency response and power-handling needed for almost any professional audio environment while still being reasonably priced. Whether you use a powered mixer or an equipment rack full of amps and signal processing, PRX400 passive speakers deliver the sound, power and bandwidth necessary to make loud music sound natural and even quiet speech intelligible. Utilising poplar and birch enclosures as well as JBL's rugged DuraFlex coating, these speakers are road tough and ready to perform in any environment.



Grille

Rugged 16-gauge grilles provide serious protection for the JBL tour tested components. Backed with acoustically transparent cloth the grilles are designed for sonic accuracy, structural strength and professional good looks.



Suspension Points

Permanently mounting the PRX400 is easily managed via twelve built-in M10 suspension points constructed from 14 gauge steel. They have been tested with a yield strength of 1000 pounds each ensuring a safe and secure mount.



Handles

Ergonomically engineered handles are made from light-weight glass-filled nylon for added strength and durability. Intelligently engineered for both balance and comfort in the hand, they make carrying, mounting and positioning each enclosure easily managed in any situation.



Pole Sockets

Built in dual-angle pole mount sockets allow the PRX412M and PRX415M to be stand mounted at different angles to accommodate the best audience coverage pattern. With a 10° down angle, the speaker can be directed down toward your audience, enhancing sound coverage and clarity.



Eye Bolts

The JBL M10 Forged Shoulder Steel Eyebolts kit contains the necessary eyebolts needed for flying and suspending most installation-ready loudspeakers.



Tri-Pod Stand

The JBL SS2BK stand is a collapsible, aluminum tri-pod stand designed exclusively for JBL pole mount speakers. Its light-weight and simple functionality make it the perfect companion to your JBL speakers.



Subwoofer Pole

The JBL SS4BK adjustable subwoofer mounting pole is the essential option for your PRX400 sub/satellite system. The pole features a safe and secure 10mm threaded end and a standard 35mm end for use in JBL pole sockets. Also available in a fixed 24in height.



Speaker Covers

Protect your investment with a rugged, padded nylon, JBL branded cover or even a hard-shell case.

PRX412M

300mm (12in) TWO-WAY POWERED STAGE MONITOR

PRX412M is a portable, 300mm (12in), two-way speaker system designed for either main sound reinforcement or monitoring applications. Black or White DuraFlex™ finish.

- Dispersion: 90° x 50° HxV
- Response: 50Hz-20kHz
- Sensitivity: 95dB
- Power: 300W* 8Ω
- Suspension: M10 x12. Dual angle pole socket.



PRX415M

380mm (15in) TWO-WAY PASSIVE STAGE MONITOR & LOUDSPEAKER SYSTEM

PRX415M is a portable, 380mm (15in), two-way speaker system designed for either main sound reinforcement or monitoring applications. Black or White DuraFlex™ finish.

- Dispersion: 90° x 50° HxV
- Response: 55Hz-20kHz
- Sensitivity: 98dB
- Power: 300W* 8Ω
- Suspension: M10 x12. Dual angle pole socket.



PRX425

380mm (15in) TWO-WAY LOUDSPEAKER SYSTEM

PRX425 dual 380mm (15in), two-way is the perfect choice for DJ's and bands who need low-frequency extension from the convenience of a stand-alone cabinet. Black DuraFlex™ finish.

- Dispersion: 90° x 50° HxV
- Response: 48Hz-20kHz
- Sensitivity: 98dB
- Power: 600W* 4Ω
- Suspension: M10 x12



PRX418S

457mm (18in) PASSIVE SUBWOOFER SYSTEM

PRX418S is an 457mm (18in) subwoofer which, when combined with the two-way models, provides a sub/sat system capable of generating 135 dB of full-range, high quality audio. Black DuraFlex™ finish.

- Response: 35Hz-250Hz
- Sensitivity: 95dB
- Power: 800W* 8Ω
- Suspension: Pole socket



EON700 Series.

ADVANCED ACOUSTIC TECHNOLOGY

Launched in 1995, JBL's best-selling EON family of PAs set the benchmark for how great a powered loudspeaker system can be. The EON700 Series represents a major step forward in innovation and technology: JBL engineers used exclusive, state-of-the-art design and measurement techniques to deliver the best-performing loudspeakers in their category, regardless of application. EON700 leverages the latest acoustic science, transducer designs, cabinet materials and advanced DSP and control technologies to deliver extraordinary performance in a fully professional, highly flexible, easy to use, portable system. With four models available, including the 10-inch EON710, the 12-inch EON712 and the 15-inch EON715 powered PA speakers and the 18-inch EON718S subwoofer, EON700 systems cover the needs of today's working musicians and sound providers.

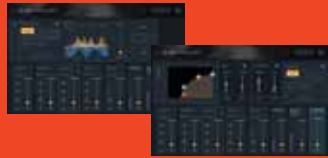

JBL PRO CONNECT APP

Available for Android and iOS phones and tablets, JBL Pro Connect opens up a world of possibilities for hands-on control over a full-suite of PRX ONE, EON ONE MK2 and EON700 mixer, DSP, and Bluetooth features. From either landscape or portrait viewing modes, the streamlined interface makes it easy to adjust and control every feature on multiple speakers from anywhere in the room.

Iconic Acoustics, Superior Sound

JBL's advanced waveguide and transducer technologies, coupled with highly efficient amplification, ensure uniform coverage across the entire listening area, even when you push the system to the limit.

Woofers are redesigned for lower impedance and higher efficiency, an improved horn delivers a smooth off-axis beamwidth and JBL's powerful 2414H compression driver features a premium neodymium magnet for balanced response in a lightweight footprint. Speakers are powered by 1,300 (loudspeakers) or 1,500 (subwoofer) watts of ultra-efficient discrete Class D amplification, for clean, clear sound. It all adds up to superior coverage, consistency and intelligibility at any volume.

System Versatility

EON700 loudspeakers can be used as main PA speakers or floor monitors. Full-range models feature top and rear suspension points for flying speakers; rear suspension points serve as connections for fixed installations, using an optional universal yoke mount. Indexed feet molded into enclosures enable a range of acoustic configurations and secure stacking for traditional stand-up configurations and convenient storage and transport. EON718S subwoofers feature a threaded pole mount for full-range speakers and are easily stacked for cardioid configurations.

Rugged and Reliable

Full-range speakers feature FEA optimized composite enclosures, taking advantage of injection-molding and mechanical-shaping techniques for added durability without sacrificing cabinet size or performance. Subwoofers are housed in rugged 15-ply birch enclosures; computer-optimized ergonomic handles make moving boxes a breeze. Every JBL Professional product undergoes stringent testing that goes above and beyond any conditions the product would face in the real world. Our industry-leading 100-hour power test ensures longevity so musicians and audio engineers can rely on JBL components in any scenario.

Mounting Bracket

The EON700 universal yoke mount provides a robust, universal design that adheres to the most stringent weight and quality standards with built-in cable slot and adjustable angle measurements for consistent design and layout.



EON710

250mm (10in) TWO-WAY POWERED LOUDSPEAKER SYSTEM

The JBL EON710 10-inch powered loudspeaker offers an all-new acoustic package featuring a completely redesigned woofer, JBL's powerful 2414H compression driver and an optimized horn, plus a range of mounting options for the ultimate in volume and versatility in mid-size and focused live and installed applications.

- Dispersion: 100°x60° HxV
- Response: 52Hz-20kHz
- Max SPL: 125dB
- Power: 1,300W peak

EON712

300mm (12in) TWO-WAY POWERED LOUDSPEAKER SYSTEM

The JBL EON712 12-inch loudspeaker is built from the ground up for unrivaled power and performance, featuring a newly engineered woofer, JBL's 2414H compression driver and an optimized horn. Yoke- and pole-mounting accessories expand configuration options, letting users tailor systems for music venues, corporate events or worship services.

- Dispersion: 100°x60° HxV
- Response: 50Hz-20kHz
- Max SPL: 127dB
- Power: 1,300W peak

EON715

380mm (15in) TWO-WAY POWERED LOUDSPEAKER SYSTEM

The JBL EON715 15-inch loudspeaker delivers superior coverage and fidelity right out of the box, thanks to upgraded custom drivers featuring JBL 2414H compression drivers and optimized horns. These speakers are ideal for supporting any mid-sized indoor or outdoor event with loud, clear sound—and because they're stackable, they're easy to store and transport.

- Dispersion: 90°x60° HxV
- Response: 45Hz-20kHz
- Max SPL: 128dB
- Power: 1,300W peak

EON718S

457mm (18in) SELF-POWERED SUBWOOFER

The JBL EON718S 18-inch powered subwoofer brings deep low-frequency extension to JBL's EON700 Series of powered loudspeakers. The EON718S produces smooth, natural bass down to 31 Hz, thanks to a newly engineered acoustic package with a completely redesigned woofer and 1,500 watts of amplification. Dial in your signature sound using the 718S' built-in parametric EQ, polarity inversion and speaker delay.

- Dispersion: omnidirectional
- Response: 31Hz-150Hz
- Max SPL: 131dB
- Power: 1,500W peak



PRX900 Series.

PROFESSIONAL POWERED PORTABLE PA LOUDSPEAKERS AND SUBWOOFERS

The JBL PRX900 Series takes professional portable PA performance to a new level with advanced acoustics, comprehensive DSP, unrivaled power performance and durability and complete BLE control via the JBL Pro Connect ecosystem. The line, which includes three powered two-way loudspeakers and two powered subwoofers, was built from the ground up to leverage JBL's most advanced acoustic innovations. New driver systems—powered by ultra-efficient 2,000-watt (peak) Class D amplifiers—deliver clarity and definition at maximum volume, with improved dispersion and smooth low-frequency extension. The PRX900 Series is a versatile solution for DJs and bands, music venues, rental houses, corporate A/V providers, or anyone who needs durable professional systems that deliver powerful, room-filling sound in any portable or installed scenario.



Dial In Your Sound with Class-Leading DSP and Control

The PRX900 Series is fully loaded with comprehensive DSP, all accessible via the JBL Pro Connect app and onboard full-color LCD. Processing includes 12-band parametric EQ and optimized system presets; onboard dbx DriveRack technology features live and fixed Automatic Feedback Suppression, soft system limiters and 180ms of speaker delay in 100-microsecond intervals for precise time-aligned systems. The JBL Pro Connect app offers BLE functionality for system control of up to 10 speakers and line integration with JBL EON ONE MK2, PRX ONE and EON700 loudspeakers. The app provides the ability to change speaker names and flash all unit LEDs for ease of speaker identification in a full ecosystem. Access full DSP functions anywhere, right from the app, including app-only features like speaker snapshots and groupings.



All-New Acoustic Design

From cones to cabinets, the PRX900 Series has been built from the ground up to leverage the latest JBL acoustic innovations. Patented JBL 2408H-2 1.5in compression drivers with poly-annular diaphragms and neodymium magnets provide clear, detailed high-frequency response even at maximum volume. High-quality NTC thermistors protect transducers by reducing power sent to transducers when approaching thermal limit. Innovative new horns with updated JBL Image Control Waveguides provide optimum beamwidth and directivity. Next-generation woofers with ferrite magnets deliver smooth, natural bass response, and an FEA flared port design reduces air noise and distortion. Subwoofers feature proprietary voicecoils for improved low-frequency response. It all adds up to clean, accurate, powerful sound at any volume.

PRX908

300mm (12in) TWO-WAY FULL-RANGE MAIN SYSTEM/FLOOR MONITOR WITH WI-FI

The JBL PRX908 powered two-way 8-inch loudspeaker leverages new acoustic innovations including the patented JBL 2408H-2 1.5in compression driver with poly-annular diaphragm and neodymium magnet for clean, detailed high-frequency response. High-quality NTC thermistors protect transducers by reducing power sent to transducers when approaching thermal limit. Redesigned horns with JBL Image Control Waveguides provide optimum coverage.

- Dispersion: 105°x60° HxV
- Response: 67Hz-20kHz
- Max SPL: 126dB
- Power: 2,000W peak



PRX912

380mm (15in) TWO-WAY FULL-RANGE MAIN SYSTEM/FLOOR MONITOR WITH WI-FI

The JBL PRX912 powered two-way 12-inch loudspeaker takes advantage of JBL's iconic 2408H-2 compression driver with poly-annular diaphragm and neodymium magnet for clean, detailed high-frequency response; a next-generation woofer with ferrite magnet delivers smooth, natural bass and mids. All-new horns and Image Control Waveguides optimize dispersion and beamwidth.

- Dispersion: 90°x50° HxV
- Response: 50Hz-20kHz
- Max SPL: 132dB
- Power: 2,000W peak



PRX915

380mm (15in) SELF-POWERED EXTENDED LF SUBWOOFER SYSTEM WITH WI-FI

The JBL PRX915 powered two-way 15-inch loudspeaker features new drivers with JBL 2408H-2 compression driver with poly-annular diaphragm and neodymium magnet, plus a next-generation woofer with ferrite magnet. PRX915 components are housed in a strong, lightweight enclosure that maximizes both acoustic performance and durability: its cabinet is constructed from a rigid polypropylene/talcum blend, with a computer-modeled internal ribbing design for maximum structural integrity and minimum cabinet noise.

- Dispersion: 90°x50° HxV
- Response: 48Hz-19kHz
- Max SPL: 133dB
- Power: 2,000W peak



PRX915XLF

457mm (18in) SELF-POWERED EXTENDED LF SUBWOOFER SYSTEM WITH WI-FI

The PRX915XLF 15-inch powered subwoofer, driven highly efficient 2,000W Class D power amps, produces bass with superior clarity and definition. High-quality, high-linearity inductors deliver high power efficiency and low total harmonic distortion, and low-noise, low-distortion input gain staging optimizes range and headroom for a diverse gain requirements. An 18mm birch cabinet features optimized bracing for smooth low-frequency response and improved durability.

- Dispersion: omnidirectional
- Response: 36Hz-98Hz
- Max SPL: 141dB
- Power: 2,000W peak



PRX918XLF

DUAL 380mm (15in) TWO-WAY FULL RANGE MAIN SYSTEM WITH WI-FI

The PRX918XLF 18-inch powered subwoofer is designed for advanced acoustic performance. A next-generation 918SG woofer with ferrite magnet delivers smooth, natural bass response, and an FEA flared port design reduces air noise and distortion. Its enclosure is built from 18mm birch, with strategically defined bracing that smooths low-frequency response. A Duraflex coating provides superior durability.

- Dispersion: omnidirectional
- Response: 30Hz-110Hz
- Max SPL: 134dB
- Power: 2,000W peak



SRX800 Series.

PASSIVE & SELF POWERED LARGE FORMAT LOUDSPEAKER SYSTEMS

SRX800 Passive

This line of premium portable speakers deliver the best sound quality, power handling, and workmanship in it's class. Custom built, industry leading JBL transducers and enclosures give SRX800 the power and ruggedness to stand up to a variety of demanding applications. JBL Professional has made a name for itself by producing great sounding, long lasting portable PA systems. With the incorporation of tunings available for Crown amplifiers and dbx signal processors, SRX800 is an optimal choice for a fully integrated Harman Professional sound system controlled through Audio Architect. Integrating industry-leading levels of sound quality, power, control, and durability, SRX800 is a perfect all in one solution wherever high performance, comprehensive control, and pristine sound are required. Each component in the SRX800 Series was purposefully designed and thought through to deliver a perfectly tuned system that is powerful, easy to use, and rugged enough for the most demanding applications. M10 suspension points, indexed feet, and pole/tripod mounts support a wide, flexible array of configurations.

SRX800 Powered

JBL Professional has made a name for itself by producing great sounding, long lasting portable PA systems. With the introduction of the SRX800 line of powered portable PA loudspeakers, JBL has set the standard for what a fully professional powered PA system should be. SRX800 breaks new ground, bringing together JBL's premium transducers and enclosures, Crown's Proprietary Front-End DriveCore Technology, user-configurable DSP, and full HiQNet Network control compatible with a variety of platforms. Integrating industry-leading levels of sound quality, power, control, and durability, SRX800 is a perfect all in one solution wherever high performance, comprehensive control, and pristine sound are required. Each component in the SRX800 Series was purposefully designed and thought through to deliver a perfectly tuned system that is powerful, easy to use, and rugged enough for the most demanding applications.



SRX812

300MM (12in) TWO-WAY BASS REFLEX PASSIVE SYSTEM

SRX812 is a two-way full range passive portable speaker with a 12in woofer made for use as a light-duty main PA, monitor, or rear or side fill. Tunings and presets are available for Crown iTech HD. Available in Obsidian DuraFlex™ finish.

Also available: SRX812P Self Powered System with Crown amplification.

- Dispersion: 90° x 50° HxV
- Response: 50Hz-20kHz
- Sensitivity: 94dB
- Power: 300W* 8Ω (Bi-Amp Switchable)
- Suspension: M10 x12. Dual angle pole socket



SRX815

380MM (15in) TWO-WAY BASS REFLEX PASSIVE SYSTEM

SRX815 is a two-way full range passive portable speaker with a 15in woofer made for use as a light-duty main PA, monitor, or rear or side fill. Tunings and presets are available for Crown iTech HD. Available in Obsidian DuraFlex™ finish.

Also available: SRX815P Self Powered System with Crown amplification.

- Dispersion: 90° x 50° HxV
- Response: 50Hz-20kHz
- Sensitivity: 95dB
- Power: 800W* 8Ω (Bi-Amp Switchable)
- Suspension: M10 x12. Dual angle pole socket



SRX835

380MM (15in) THREE-WAY BASS REFLEX PASSIVE SYSTEM

SRX835 is a three-way full range speaker with a 15in woofer made for use as a medium duty main PA, or rear or side fill. Tunings and presets are available for Crown iTech HD. Available in Obsidian DuraFlex™ finish.

Also available: SRX835P Self Powered System with Crown amplification.

- Dispersion: 60° x 40° HxV
- Response: 32Hz-20kHz
- Sensitivity: 98dB
- Power: 800W* 8Ω
- Suspension: M10 x12. Pole socket



SRX818S

457MM (18in) PASSIVE SUBWOOFER SYSTEM

SRX818S is a single 18in subwoofer for concert, touring, or installed use. Featuring a standard M20 pole cup for use with top boxes, indexing feet for stacking in both the standard and cardioid position, and a 136dB max SPL, the SRX818S is an ideal solution for musicians, bands, and DJs, concert use, public speaking, or in performance venues, corporate spaces, educational facilities or houses of worship. Tunings and presets are available for Crown iTech HD. Available in Obsidian DuraFlex™ finish.

Also available: SRX818SP Self Powered System with Crown amplification.

- Response: 28Hz-150Hz
- Sensitivity: 95dB
- Power: 600W* 8Ω
- Suspension: M20 Pole socket



SRX828S

457MM (18in) DUAL SUBWOOFER

SRX828S is a dual 18in subwoofer for concert, touring, or installed use. Featuring a wide stance for splaying top boxes, indexing feet for stacking in both the standard and cardioid position, and a 141dB max SPL, the SRX828S is an ideal solution for musicians, bands, and DJs, concert use, public speaking, or in performance venues, corporate spaces, educational facilities or houses of worship. Tunings and presets are available for Crown iTech HD. Available in Obsidian DuraFlex™ finish.

Also available: SRX828P Self Powered System with Crown amplification.

- Response: 30Hz-150Hz
- Sensitivity: 98dB
- Power: 1200W* 4Ω
- Suspension: M20 Pole socket



*2 Hour IEC with 8dB Crest.

EON ONE Compact.

ALL-IN-ONE BATTERY-POWERED PORTABLE PA WITH PROFESSIONAL-GRADE MIXER

The days of sacrificing sound system power and performance for portability are over. The JBL EON ONE Compact packs a professional speaker, a full-featured, 4-channel mixer and Bluetooth control into our most compact battery-powered PA, weighing in at just 17.6 pounds. Sound your best in seconds with premium Lexicon and dbx-inspired effects and presets that you can customize right on your phone or tablet using the JBL EON ONE Compact Control app—no engineer needed. Presenters, fitness instructors and emcees will appreciate EON ONE Compact's ducking feature, which lowers background music volume when speech input is detected. Peer-to-peer Bluetooth lets you broadcast music playback. And with EON ONE Compact's tool-free, swappable 12-hour battery, you'll keep the party going long after the sun goes down.

- 112 dB output the highest volume in its class
- Best in class low - down to 37Hz
- Ultralight unit weighs just 17.6 pounds (8 kg)
- Effects including EQ, reverb, chorus and delay
- Built-in 4-channel mixer
- Bluetooth connectivity



EON ONE MK2.

ALL-IN-ONE RECHARGEABLE COLUMN PA WITH BUILT-IN MIXER AND DSP

The JBL EON ONE MK2 packs a class-leading acoustic package, 5-channel digital mixer, dbx and Lexicon DSP, Bluetooth functions and universal app control into a lightweight, portable package. The EON ONE MK2 delivers the fidelity JBL is legendary for, combining a geometrically optimized, C-shaped 8-tweeter array with a 10in woofer to deliver class-leading clarity and coverage down to 37 Hz, with wide dispersion and a maximum output of 123 dB. The EON ONE MK2 is engineered for versatility and ease of use: Dial up your sound in an instant, thanks to a full suite of pro-grade Lexicon and dbx effects and presets. Variable Power Performance automatically optimizes power performance for AC or battery operation. Bluetooth audio streaming and six-hour battery operation round out the advantages of this all-in-one system.

- C-shaped array of (8)2in tweeters
- Natural, smooth low end, down to 37 Hz
- Variable Power Performance
- Built-in 1,500-watt (peak) amplifier
- Frequency response: 37 Hz–20 kHz
- Easily swappable 6-hour battery



USB POWER CABLE

Adding even greater freedom and flexibility to your live sound setup, the JBL EON ONE Compact USB Power Cable allows you to easily power an AKG wireless system on a DigiTech-DOD guitar pedal directly from your JBL EON ONE Compact battery-powered portable P.A. With a USB A connection that plugs into your speaker and a 5.5mm power terminal that connects to an AKG DMS or WMS system or a wide range of DigiTech-DOD pedals, the cable lets you use your EON ONE Compact's rechargeable battery to power select external devices.



CLASS-LEADING CONNECTIVITY

The EON ONE Compact offers more inputs than any system in its class. Two XLR/TRS combo jacks, one 1/4-inch hi-Z guitar input and one 1/8-inch aux input connect microphones, line-level instruments and audio playback sources; phantom power supports condenser microphones, and pro-grade preamps deliver full, rich sound from any microphone. Plus, a 1/4-inch passthrough lets you expand your system with additional EON ONE Compact units. Use the built-in headphone jack to rehearse privately or dial in presets before performances. Two high-power USB 3.0 ports allow high-speed charging of tablets, phones and select DJ devices.



LONG-LASTING BATTERY LIFE

Play more sets or teach more classes, confident in EON ONE Compact's 12-hour battery life. Swap out batteries in seconds—no tools necessary—and quick-change batteries in just 2.5 hours. You can even charge while the system is in use.

SOUND YOUR BEST WITH PRO FX

EON ONE MK2 features a full suite of professional DSP, including Lexicon reverb, chorus and delay and dbx DriveRack Inside technology, including AFS (Automatic Feedback Suppression) and 9-band EQ. Presenters, fitness instructors and emcees will appreciate the Soundcraft Easy Ducking feature, which lowers background music volume anytime you speak. DSP presets and onboard hardware EQ with 3 fixed knobs make it even easier to hone your signature sound, fast.



EON ONE MK2 DUAL BATTERY CHARGER

The JBL EON ONE MK2 dual battery charger is the perfect accessory to accompany the EON ONE MK2 for those long gigs that require extended performance power to take you late into the evening or early into the morning.



POWER THAT WORKS SMARTER, NOT HARDER

EON ONE MK2's robust 1,500-watt (peak) amplifier ensures clean, distortion-free sound at any volume level. Variable Power Performance technology optimizes performance for either AC or battery power, providing 4 dB extra headroom when connected to AC power. You'll be heard loud and clear, no matter where you play.

TOTAL CONTROL, AT YOUR FINGERTIPS

EON ONE MK2 can be controlled by the universal JBL Pro Connect app, which provides remote access to every function and preset, right from your phone or tablet; JBL's ActiveSync technology ensures the app and system LCD are always in perfect sync. The EON ONE MK2 offers Bluetooth 5.0 audio streaming to one device, with control of up to 10 units.



12-hour Battery



Bluetooth Connectivity



Best-in-Class Output/LF Ext.



One-Touch Ducking



EQ, Reverb, Delay, Chorus



7 Year Warranty



Built-in Mixer



App Control



PRX ONE. ALL-IN-ONE POWERED COLUMN PA WITH MIXER AND DSP

The JBL PRX ONE all-in-one powered column PA features an acoustically optimized column array featuring a 7-channel digital mixer, a full suite of professional DSP, class-leading audio connectivity, Bluetooth functionality and JBL Pro Connect universal app control. PRX ONE delivers a stunning 130db max SPL, with consistent front-to-back throw, thanks to its custom-engineered 12-tweeter column array featuring JBL AIM acoustic technology, 12-inch bass-reflex woofer and built-in 2,000-watt (peak) amplifier. Work faster and easier with an intuitive Soundcraft-designed dual-mode digital mixer that can be set to general mix functions or channel-strip control, all controllable via app or a built-in color LCD.

- Vertical array of (12) 2.5-inch drivers
- Custom-designed high-frequency drivers
- JBL A.I.M. (Array Innumeration Mechanics)
- Wide, 130° (H) x 30° (V) dispersion pattern
- Extended low-end response to 35 Hz
- 2,000-watt (peak), fully bridged Class D amplifier

EVERYTHING YOU NEED TO DIAL IN YOUR SIGNATURE SOUND

Who wants to lug cumbersome outboard effects to gigs? Sculpt your sound right inside PRX ONE with a full suite of iconic dbx and Lexicon audio effects, including reverb, delay, chorus, echo, compression, limiting and gating. Presenters, teachers and fitness instructors will always be heard loud and clear when they rely on PRX ONE's built-in ducking feature, which lowers background music when speech is detected. Presets let you save and recall go-to settings. Four console-quality microphone preamps maintain full bandwidth, even at maximum gain. It all adds up to clean, clear, studio-quality sound, no matter how loud you go.



EASY MOUNTING BRACKET KIT

PRX ONE can be used in both portable applications and fixed installations; installers, presenters and houses of worship will appreciate the ability to detach and mount the PRX ONE array separately from the subwoofer, using an optional mounting accessory.

PRISTINE POWER AT ANY VOLUME

Go ahead, crank it up with confidence, thanks to ultra-efficient amplification that ensures you'll be heard loud and clear at any volume level. PRX ONE's 2,000-watt Class D amplifier with power factor correction delivers clean, stable power through various voltages, ensuring longevity of components and reliable operation anywhere. High-quality, high-linearity inductors improve efficiency and minimize total harmonic distortion. And, because the amp is fully bridged, you'll truly tap its full power potential, with plenty of headroom to handle any scenario.

AN ALL-IN-ONE CONTROL ECOSYSTEM

Get hands-on anywhere with the JBL Pro Connect app, which offers control over every PRX ONE feature from mixing to DSP to Bluetooth functions. Adjust levels from anywhere in the room. Because the app and the mixer are always in sync, you'll never have to guess where your levels are. Plus, get access to Plus get access to app-only features like speaker grouping, delay tap tempo, and whole speaker snapshots.

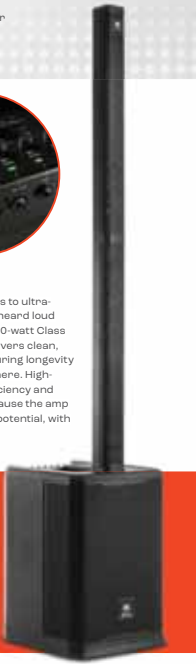

STUDIO MONITORS



3 Series MKII. POWERED STUDIO MONITORS

The 3 Series Powered Studio Monitors are the first to incorporate JBL's groundbreaking Image Control Waveguide from our flagship M2 Master Reference Monitors. Unprecedented detail, imaging and depth clearly reveal micro-dynamics in reverb tails, subtleties of mic placement, and a tangible sense of a centre channel speaker. A broad, room-friendly sweet spot ensures equal dimension and transparency for everyone in the room. With legendary JBL transducers and custom-designed power amplifiers, the 3 Series will boost the image in your studio. With three different models to choose from, there's a 3 Series monitor to fit your studio and budget.

305P MKII 127mm (5IN) POWERED TWO-WAY STUDIO MONITOR

The 127mm (5in) 305P MkII offers a remarkably full sound in an enclosure small enough to fit in the tightest workspace. Available in Matte Black pvc finish.

- Dispersion: 120° x 90° HxV
- Response: 43Hz-24kHz
- Power: 41-watts x2, Class D, Bi-Amp



306P MKII 165mm (6.5IN) POWERED TWO-WAY STUDIO MONITOR

The 165mm (6.5in) 306P MkII is perfect if you need even more volume and bass response while still maintaining a compact footprint. Available in Matte Black pvc finish.

- Dispersion: 120° x 90° HxV
- Response: 39Hz-24kHz
- Power: 56-watts x2, Class D, Bi-Amp



308P MKII 200mm (8IN) POWERED TWO-WAY STUDIO MONITOR

The 200mm (8in) 308P MkII is the largest and most powerful of the three models in the series, offering impressive low end, high output and excellent dynamic range. Available in Matte Black pvc finish.

- Dispersion: 120° x 90° HxV
- Response: 37Hz-24kHz
- Power: 56-watts x2, Class D, Bi-Amp



LSR310S 254mm (10IN) POWERED STUDIO SUBWOOFER WITH XLF

Extend your system LF all the way down! The LSR310S subwoofer incorporates JBL's patented Slip Stream™ Port working in concert with a custom 10in down-firing driver and a 200 Watt amplifier to add deep, powerful bass to any studio monitor system. A JBL first, the XLF Extended Low Frequency setting lets you hear your tracks with the augmented bass tuning used in today's dance clubs. Available in Matte Black pvc finish.

- Response: 27Hz-80Hz
- Power: 200-watts, Class D



7 Series. MASTER REFERENCE MONITORS

The JBL 7 Series provides a powerful and flexible monitoring solution for music, post and broadcast production. Now available in four models—the install 705i and 708i and the powered 705P and 708P—these monitors deliver exceptional output, stunning detail, an expansive soundstage and impressive accuracy. 7 Series speakers achieve this outstanding performance by leveraging patent-pending driver technologies and the renowned JBL Image Control Waveguide. All models integrate with the Intonato 24 Monitor Management Tuning System, which provides intuitive remote control and calibration. 7 Series monitors are equally at home in stereo, surround, and immersive-audio production rooms.



705i 127mm (5IN) MASTER REFERENCE MONITOR

The 705i is an essential next generation multi-channel monitor for post rooms, broadcast facilities and trucks. Leveraging patented technologies developed for our flagship M2 Master Reference Monitor, the 705i delivers detailed imaging, extended frequency response and remarkable output from compact enclosures. Centrally amplified and tuned, and easily installed, the 705i is the heart of an elegant, scalable system for broadcast and post facilities.

- Next Generation Systems for Post and Broadcast Production
- Next Generation Driver Technology
- Patent Pending Image Control Waveguide
- Compact, Install Friendly Enclosures



708i 203mm (8IN) MASTER REFERENCE MONITOR

Leveraging patented technologies developed for our flagship M2 Master Reference Monitor, the 708i delivers detailed imaging, extended frequency response and remarkable output from compact enclosures. Centrally amplified and tuned, and easily installed, the 708i Studio Monitor is the heart of an elegant, scalable system for broadcast and post facilities working in immersive audio formats.

- Next Generation Systems for Post and Broadcast Production
- Next Generation Driver Technology
- Patent Pending Image Control Waveguide
- Compact, Install Friendly



705P 127mm (5IN) BI-AMPLIFIED MASTER REFERENCE MONITOR

The JBL 705P is a self-powered reference monitor for critical music recording, film post and broadcast production applications. It leverages the same patent-pending driver technologies and JBL's renowned Image Control Waveguide found in the 708P and the flagship M2, but with a smaller footprint. Despite its compact size, JBL 705P delivers an eye-opening level of output, well beyond that of existing, comparably-sized studio monitors, for greater dynamic range and greater working distances.

- Next-generation JBL driver technology
- Image Control Waveguide
- Dual amplification system
- Room EQ and delay controls
- Compact enclosure



708P 203mm (8IN) BI-AMPLIFIED MASTER REFERENCE MONITOR

JBL 708P is a self-powered reference monitor for critical music recording, film post and broadcast production applications. The 708P leverages new patent-pending driver technologies and JBL's renowned Image Control Waveguide to deliver extraordinary output, stunning detail, an expansive soundstage, and greater accuracy in a broad range of rooms. 708P delivers several times the output of other comparably-sized studio monitors, providing significantly greater dynamic range and greater working distances.

- Next-generation JBL driver technology
- Image Control Waveguide
- Dual amplification system
- Room EQ and delay controls
- Compact enclosure



CINEMA SPEAKERS



SFC Yonghua Cinema City, China

200 Series. TWO-WAY SCREENARRAY® LOUDSPEAKERS

The 200 Series combines JBL's latest technological advances with a compact footprint and accessible price point, making it easy to upgrade the sonic experience in your small or mid-sized cinema. Featuring patent-pending Dual Dissimilar Arraying and Acoustic Aperture Technology, the JBL 200 series provides remarkably uniform coverage and smooth, accurate sound reproduction for every member of your audience. Models range from 12-14in thin, perfect for small and medium multiplexes with space constraints. And since the 200 Series uses the same driver technology trusted by top movie studios around the world, your audience will enjoy a more captivating, authentic experience from every seat in the house—just like the creators intended.

C211 TWO-WAY SCREENARRAY CINEMA LOUDSPEAKER

The C211 has a depth of 12in, making it perfect for small cinemas with space constraints. The C211 uses the same high frequency driver technology that is found in the 7 Series master reference studio monitors, which is trusted by top movie studios around the world, your audience will enjoy a more captivating, authentic experience from every seat in the house—just like the creators intended. With a maximum throw of 16m (52'), the C211 is designed for a small to medium cinema as well as VIP viewing rooms.

- Next-generation two-way ScreenArray®
- 12in footprint
- Advanced passive crossover network
- 2409H uses same HF driver



C221 TWO-WAY SCREENARRAY CINEMA LOUDSPEAKER

Featuring patent-pending Dual Dissimilar Arraying and Acoustic Aperture Technology, the C221 provides remarkably uniform coverage and smooth, accurate sound reproduction for every member of your audience. The C221 has a depth of 12in, making it perfect for small and medium multiplexes with space constraints.

- Next-generation two-way ScreenArray®
- 12in footprint
- Advanced passive crossover network
- 2409H uses same HF driver



C222 TWO-WAY SCREENARRAY CINEMA LOUDSPEAKER

The C222 is ideal for small and medium multiplexes, studios and dubbing stages with space constraints. And since the C222 uses the same driver technology trusted by top movie studios around the world, your audience will enjoy a more captivating, authentic experience from every seat in the house.

- Next-generation two-way ScreenArray®
- Dual Dissimilar Arraying Technology
- Acoustic Aperture Technology
- 12in footprint



C222HP TWO-WAY HIGH PERFORMANCE SCREENARRAY CINEMA LOUDSPEAKER

The C222HP is perfect for small and medium multiplexes, studios and dubbing stages with space constraints. And since the C222HP uses the same driver technology trusted by top movie studios around the world, your audience will enjoy a more captivating, authentic experience from every seat in the house—just like the creators intended.

- Next-generation two-way ScreenArray®
- Dual Dissimilar Arraying Technology
- Acoustic Aperture Technology
- 14in footprint



ScreenArray Systems (3-Way).

THREE-WAY SCREENARRAY® LOUDSPEAKERS

The 200 Series combines JBL's latest technological advances with a compact footprint and accessible price point, making it easy to upgrade the sonic experience in your small or mid-sized cinema. Featuring patent-pending Dual Dissimilar Arraying and Acoustic Aperture Technology, the JBL 200 series provides remarkably uniform coverage and smooth, accurate sound reproduction for every member of your audience. Models range from 12-14in thin, perfect for small and medium multiplexes with space constraints. And since the 200 Series uses the same driver technology trusted by top movie studios around the world, your audience will enjoy a more captivating, authentic experience from every seat in the house—just like the creators intended.



Wein Cinema, Shanghai

High Power Screen Arrays.

FOUR-WAY HIGH POWER SCREENARRAY® LOUDSPEAKERS

The JBL 4-Way High Power ScreenArray Loudspeakers are available in two systems feature a 150 Watt, 4in titanium diaphragm high-frequency compression driver on JBL's patented Optimized Aperture waveguide with Screen Spreading Compensation™. The 5742 system features a quad mid-range array of four 8in Differential Drive® cone mid-range drivers providing 1400 Watts of smooth coverage, coupled with a dual .18in SVG™ Super Vented Gap low-frequency section, providing 1600 Watts of high power output with minimum distortion. The 5732 dual-mid-range version using a dual 15in, 1200 Watt, low-frequency section is also available.



Filmpalast Kassel, Germany

3732 / 3732-T

THREE-WAY BIAMPLIFIED OR TRIAMPLIFIED(T) SCREENARRAY LOUDSPEAKER SYSTEM

Today's premier cinemas require perfect coverage in every seat of the auditorium, wide dynamic range and extended bandwidth, as well as inaudible levels of distortion. Digital soundtracks, especially those associated with the latest digital cinema requirements, require sound systems that can accurately reproduce the sound exactly as recorded. The 3732/3732-T ScreenArray Cinema Loudspeaker System features true three-way design enhanced by advanced engineering. JBL's latest technical innovations are integrated into a system design that provides superior coverage, maximum power handling and uniform acoustic power output, along with extremely low distortion. The ScreenArray design provides ideal power response and directivity control with seamless transitions between acoustic sections.

- Three-way ScreenArray™
- Triamplified (T) or Bi-amplified operation
- Second Generation Optimized Aperture Waveguide
- SSC™ Screen Spreading Compensation
- Focused Coverage Technology™



5732

3-WAY HIGH POWER SCREENARRAY LOUDSPEAKERS

Today's premier cinemas require perfect coverage in every seat of the auditorium, wide dynamic range and extended bandwidth, as well as inaudible levels of distortion. Digital soundtracks require sound systems for premier auditoriums that can accurately reproduce the sound exactly as recorded. Designed for high power critical sound reproduction in premier cinemas, studio production and post production applications, the 5732 high power ScreenArray features true three-way design, enhanced by advanced engineering. JBL's latest technical innovations are integrated into a system design that provides superior coverage, maximum power handling and uniform acoustic power output, along with extremely low distortion. The ScreenArray design provides ideal power response and directivity control with seamless transitions between acoustic sections.

- Three-way ScreenArray® design
- 700 watt midrange
- Large format 4in neodymium
- 1200 W low-frequency section
- JBL Patented SSC™ Screen spreading Compensation
- Focused Coverage Technology



4732 / 4732-T

THREE-WAY BIAMPLIFIED OR TRIAMPLIFIED(T) SCREENARRAY LOUDSPEAKER SYSTEM

Digital soundtracks, especially those associated with the latest digital cinema requirements, require sound systems that can accurately reproduce the sound exactly as recorded. The 4732/4732-T ScreenArray Cinema Loudspeaker System features true three-way design enhanced by advanced engineering. JBL's latest technical innovations are integrated into a system design that provides superior coverage, maximum power handling and uniform acoustic power output, along with extremely low distortion. The ScreenArray design provides ideal power response and directivity control with seamless transitions between acoustic sections.

- Three-way ScreenArray™
- Triamplified (T) or Bi-amplified operation
- Second Generation Optimized Aperture Waveguide
- SSC™ Screen Spreading Compensation
- Focused Coverage Technology™



5742

4-WAY HIGH POWER SCREENARRAY LOUDSPEAKERS

Large format and 3D cinemas require perfect coverage in every seat of the auditorium, wide dynamic range and extended bandwidth, as well as inaudible levels of distortion. Digital soundtracks require sound systems for premier auditoriums that can accurately reproduce the sound exactly as recorded. Designed for high power critical sound reproduction in large format cinemas, studio production and post production applications, the 5742 high power ScreenArray features true four-way design enhanced by advanced engineering. JBL's latest technical innovations are integrated into a system design that provides superior coverage, maximum power handling, and uniform acoustic power output, along with extremely low distortion. The ScreenArray design provides ideal power response and directivity control with seamless transitions between acoustic sections.

- Four-way ScreenArray® design
- 1400 watt midrange
- Large format 4in neodymium
- 1600 W low-frequency section
- JBL Patented SSC™ Screen spreading Compensation
- Focused Coverage Technology



9300 Series. CINEMA SURROUND LOUSPEAKERS

Let your audience hear the truth in every cinematic experience with the JBL 9300 Surround Series. The 9300/9310 Cinema Surround Loudspeakers feature JBL Image Control Technology and asymmetric pattern control guided by exclusive Wave Shaping Vanes that distribute a sculpted, acoustic wave-front. The 9350 uses three patent pending technologies (Dual Dissimilar Arraying, Acoustic Divider Waveguide, and Bi-pole Wall Decoupling) to be the ideal choice for gap, rear or side surround speakers and provide a much larger sweet spot than traditional loud speaker technologies. Elevate your next cinema sound project with the JBL 9300 Surround Series.

9300
SURROUND SERIES
9300 · 9310 · 9320 · 9350



Humax Cinema, Japan

9300 CINEMA SURROUND LOUSPEAKER 2-WAY PASSIVE 1IN HF, 10IN WOOFER (2IN VC)

The 9300 Cinema Surround offers high 250 Watt power handling capability, high sensitivity, and extended base response in a groundbreaking design. The two-way 9300 features new transducer technologies, waveguide and horn designs developed specifically to produce studio quality performance with pattern control tailored to modern theatre geometries.

- 250 Watt Power handling capability
- Wave Shaping Vane
- JBL Image Control Technology
- Lightweight, Rigid molded enclosure
- Uniform asymmetric 60 degree vertical coverage and 110 degree horizontal coverage



9310 HIGH POWER CINEMA SURROUND LOUSPEAKER 2-WAY PASSIVE 1IN HF, 10IN WOOFER (2IN VC)

The 9310 Cinema Surround offers high 350 Watt power handling capability, high sensitivity, and extended base response in a groundbreaking design. The two-way 9310 features new transducer technologies, waveguide and horn designs developed specifically to produce studio quality performance with pattern control tailored to modern theatre geometries.

- 350 Watt Power handling capability
- Wave Shaping Vane
- JBL Image Control Technology
- Lightweight, Rigid molded enclosure
- Uniform asymmetric 60 degree vertical coverage and 110 degree horizontal coverage



9320 12IN HIGH POWER CINEMA SURROUND FOR MULTI CHANNEL APPLICATIONS

The 9320 Cinema Surround Speaker offers very high power handling, high sensitivity, and extended bass response. The two-way 9320's performance features position it as the ideal high power surround for multi-channel surround applications.

- 35 Hz to 20 kHz Frequency Range
- High Sensitivity, 98 dB SPL, 1 w, 1 m (3.3 ft)
- High Power Handling Capability
- 120° x 60° Coverage
- Multi-ply birch enclosure



9350 127mm (5IN) MASTER REFERENCE MONITOR

The 9350 packs a sonic punch, and delivers extraordinary coverage through its advanced engineering, including three patent-pending technologies. Each loudspeaker generates a sculpted side or rear pattern, adjusted with the flick of a switch. With a passive crossover network, waveguide technologies, and line array techniques, coverage can be adjusted to fit a theatre's unique environment.

- 35 Hz to 20 kHz Frequency Range
- High Sensitivity, 98 dB SPL, 1 w, 3.3 ft
- High Power Handling Capability
- 120° x 60° Coverage
- Multi-ply birch enclosure



JBL Sculpted Surround Providing a flawless surround sound experience to every seat in your cinema

After analyzing the dispersion of sound in a stadium-seating environment, JBL designed the 9300 Cinema Surround Loudspeakers with specific directivity for that geometry. The surrounds were designed with a 15-degree tilt built into the back panel and mounting system. By angling the side surrounds 15 degrees toward the screen, the hotspot and rearward bias have been eliminated while considerably broadening the sound coverage in the theater.

This arrangement is called the JBL Sculpted Surround System because it shapes the sound radiation pattern of the room into a pattern that compliments the screen channels. For easy implementation of the Sculpted Surround System, the 9300 and 9310 are equipped with a mounting mechanism so theater installers can easily position them with the 15-degree tilt.

Besides expanding the audience sweet spot, another major benefit of tilting the surrounds is that the coverage improvements reduce the number of loudspeakers required in the each theater. Because of the speakers' specific directivity and new positioning, each covers a slightly larger area, and can, therefore, be incrementally separated along the wall.

To improve the rear channel issue, JBL developed the JBL 9350, a configurable pattern speaker with three patent-pending technologies. It's the first surround loudspeaker to offer rear coverage directivity as one of its options. When you set them to be positioned in the rear, you only need a single stereo pair for small and medium rooms. When using them as left and right rear mains, there's no need to have additional speakers in the back of the theater.

Traditional 5.1/7.1 Surround Sound

Typical surround loudspeakers that are not adjusted for the inclined rake in theaters can create a buildup and uneven distribution of surround information. As a result, moviegoers may have vastly different surround sound experiences in the same room.

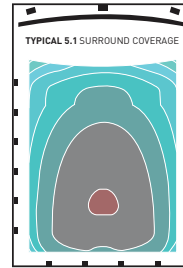

Sculpted Surround (5.1/7.1 System)

A sculpted surround system accommodates stadium seating in order to evenly deploy sound throughout the room. Designed specifically for 5.1 and 7.1 surround systems in cinemas, sculpted surround ensures uniformity so that moviegoers experience sound the way moviemakers intended.

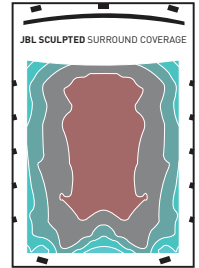

Cinema Subwoofers.

PROFESSIONAL CINEMA SUBWOOFERS

No other manufacturer provides a wider, more cost-effective range of solutions to take on the demands of modern cinema sound reproduction than JBL Professional. With one of the longest track records in the industry (James B. Lansing Sound, Incorporated manufactured some of the world's first true high-fidelity loudspeakers for cinema sound systems) and JBL's legendary reputation for quality, reliability, and innovation, it's easy to see why today more than three quarters of all cinema loudspeakers sold worldwide come from JBL Professional.



Sai Teerth Devotional Theme Park, Mumbai

CINEMA AMPLIFIERS



Century City Cinema, India

4642A

4642A DUAL 460mm (18 IN.) SUBWOOFER SYSTEM

The JBL Model 4642A is a high quality subwoofer system, featuring an advanced technology 460 mm (18 in.) low frequency transducers mounted in a direct radiator, bass-reflex enclosure for smooth response to the lowest audible frequencies. The 4642A is ideal for low-frequency augmentation of either analog or digital soundtracks in motion picture theaters and for general sound reinforcement applications.

- 1200 Watts Continuous
- Usable response to 22 Hz
- High Power Handling Capability
- 2241H VGOTM Vented Gap Cooled Drivers
- Approved by Lucasfilm, Ltd. for THX® installations



5628

ULTRA LONG EXCURSION VERY HIGH POWER DUAL 18IN CINEMA SUBWOOFER

The 5628 is a high power, lightweight front-loaded vented subwoofer enclosure housing two of JBL's exclusive 2269H Ultra Long Excursion 18in Differential Drive™ woofers. This woofer features neodymium magnet, dual voice coils and dual gaps. JBL's exclusive Vented Gap Cooling™ and ultra robust composite cone for high excursion and extra long life. Woofer is capable of a peak-to-peak maximum excursion of 89 mm (3.5in).

- 2 x 2269H 18in Differential Drive™
- 4000 watts continuous pink noise
- Ultra Long Excursion
- Large vent area for high output with low distortion



4281F

PROFESSIONAL HIGH-POWER CINEMA SUBWOOFER

The 1,600-watt 4281F delivers room-shaking low end for a variety of cinema configurations, including Dolby Atmos and DTS:X installations. The 4281F works seamlessly with the entire JBL Cinema Series, which includes two 3-way screen speakers and a surround speaker. Combine Cinema Series speakers with the JBL CP12000 cinema processor and Crown XLC Series amps to build a fully integrated JBL cinema sound solution.

- 1600 Watts Continuous power
- 139 dB peak SPL
- Built-in rigging points
- Binding post input connectors
- Frequency response: 30 Hz-500 Hz



3181F

PROFESSIONAL HIGH-POWER CINEMA SUBWOOFER

The 650-watt 3181F delivers room-shaking low end for a variety of cinema configurations, including Dolby Atmos and DTS:X installations. The 3181F works seamlessly with the entire JBL Cinema Series, which includes two 3-way screen speakers and a surround speaker. Combine Cinema Series speakers with the JBL CP12000 cinema processor and Crown XLC Series amps to build a fully integrated JBL cinema sound solution.

- 650 Watts Continuous power
- 132 dB peak SPL
- Built-in rigging points
- Binding post input connectors
- Frequency response: 30 Hz-500 Hz



DSi 2.0 SERIES AMPLIFIERS

MORE POWER. MORE RELIABILITY.

The DSi 2.0 amplifier family, JBL's first line of dedicated cinema amplifiers, builds on Crown DSi Digital Screen Array amplifier technology, integrating best-in-class DSP from Crown's flagship CDI DriveCore series to deliver potent, cost-effective amplification for JBL's entire range of cinema loudspeakers. Choose from three power configurations, available in analog and analog-plus-digital "D" versions featuring Dante/AES67 connectivity.

Deploy systems faster and easier while streamlining hardware needs: DSi 2.0 amplifiers are designed to meet power requirements of JBL cinema speakers, for a single JBL cinema solution. D models interface with Dolby Atmos directly, without the need for additional processing hardware. JBL Cinema Speaker presets simplify configuration, optimize playback audio and protect against equipment damage. All DSi 2.0 amps feature SNMP connectivity for networked audio distribution, immersive installations and direct interfacing with third-party theater-management and cinema-control systems.

RATED POWER SPECIFICATIONS			
	SA4 & SA4-D	MA4 & MA4-D	LA4 & LA4-D
8Ω	350W x 4	750W x 4	1,900W x 4
4Ω	700W x 4	1,400W x 4	2,200W x 4
2Ω	1,050W x 4	2,100W x 4	1,200W x 4
8Ω (Bridged)	1,900W x 2	2,600W x 2	4,000W x 2
4Ω (Bridged)	2,200W x 2	4,200W x 2	2,900W x 2

- An intuitive front-panel LCD and encoder interface let you configure amplifier settings at the push of a button.
- Ultra-quiet operation: 51dBA maximum fan noise
- All models are standard 19 inch (482mm) 2RU rackmount units.
- Weight: 23.2 pounds (10.5 kg)
- Frequency response: 20 Hz-20 KHz
- Power supply: 100-220V +/- 10%, 50/60 Hz
- Power connector: Standard IEC type, 320 inlet for detachable connector, 100-240V



XLC SERIES AMPLIFIERS

SMALL THEATER, BIG SOUND

From staying on top of your concession inventory to scheduling personnel to payroll management, keeping your small theater running smoothly can keep you can count on to deliver the best cinematic sound for each and every movie. Crown's affordable new XLC Series amplifiers, paired with JBL's cinema sound products, makes your choice simple and easy. Both the XLC2500 and XLC2800 amps include Crown's DriveCore™ Technology, which replaces up to 500 parts with one small chip. This significantly reduces the part count, increasing reliability and energy efficiency while maintaining brilliant performance.

RATED POWER SPECIFICATIONS			
	XLC2500	XLC2800	XLC21900
8Ω	300W x 2	400W x 2	1,000W x 2
4Ω	500W x 2	775W x 2	1,900W x 2
2Ω	775W x 2	1,200W x 2	
8Ω (Bridged)	1,000W x 2	1,550W x 2	2,700W x 1
4Ω (Bridged)	1,550W x 2	2,400W x 2	

- Power for 2-ohm, 4-ohm and 8-ohm outputs, supporting stereo and bridge outputs
- Support parallel connection of cinema surround speaker Indicators provide accurate diagnostics: Power, Signal, Clip and Fault
- Volume control on rear panel of amplifiers
- High performance, light weight
- Minimal front panel control; block connectors and controls on back of amplifiers

CINEMA PROCESSOR



Wein Cinema, Shanghai

JBL COMMERCIAL SERIES



CPI2000 CINEMA PROCESSOR



Place Your Audience In The Middle Of The Action

Deliver a theatre sound experience that's as enveloping as the excitement onscreen. Professional features like DSP, EQ, crossover, loudspeaker management, JBL cinema speaker presets and customizable software functions let you fine-tune each system with total precision, while a user-friendly LCD screen interface and front-panel volume control let theatre staff manage their systems with ease. It's all part of creating an unforgettable movie experience that will keep audiences coming back and keep your cinema customers happy.

Features

Easy to Use

Features like GUI Software and one volume knob makes for simple setup and operation

Built-in Crossover

Up to 7.1 channels with support for passive, bi-amp or tri-amp crossover configurations

Supports TMS Communication

Theater Management System communication provides convenient remote control and saves on system operation cost

JBL Cinema Speaker Presets

Reduces tuning time while optimizing sound quality

Large LCD Display

Provides system status at a glance

USB Connector

For preset file import and export

Highlights

A Complete HARMAN 7.1 Cinema Solution

When combined with Crown cinema amplifiers and JBL cinema speakers, the CPI2000 completes the HARMAN roster to deliver next-generation performance and value to 7.1 cinemas around the world.

Better Sound With Less Effort

With speaker presets for a variety of JBL cinema speakers and a 1/3 octave GEQ for room tuning via an RTA microphone (sold separately) and GUI software, the CPI2000 does much of the heavy lifting, making system tuning a breeze.

Easy Operation

The GUI software and integrated tuning system make it easy to configure and optimize the sound system. Once installed, the large front-panel LCD display and controls make it easy for staff to monitor the system, select sources and adjust volume.

Over-Network System Monitoring & Redundancy

Monitor status of speakers and amps via the front-panel LCD display, GUI software or TMS. And if a fault does occur, the built-in fault detection system sends a notification and automatically re-routes audio to the Redundant Output.

JBL® Commercial Series, a dynamic blend of the best HARMAN brands, knows for any business, the audio system is essential to keeping your customers informed and captivated.

Leveraging the expertise honed by years of precision sound reproduction and technical innovation by JBL and other HARMAN brands, JBL Commercial crafts top-quality components to offer you high-performance yet affordable sound systems.

By providing a premium listening experience for decades in everything from large arenas to private homes, JBL is one of the most recognised and respected brands in the audio industry. Capitalising on JBL's legendary achievements in audio engineering and technology enables JBL Commercial to set new standards in sound.

That means you'll find that our integrated array of mixer-amplifiers, amps, mixers, speakers, microphones, and wall controllers delivers precise, reliable sound in any commercial application, from soothing spas to bustling bars.

As your single-brand source, JBL Commercial Series simplifies the search for high-performance, comprehensive and versatile audio solutions for your business.

Visit www.jblcommercialproducts.com for more information.



Amplifiers.

COMMERCIAL SERIES AMPLIFIERS



CSA140Z/180Z/1120Z 1 X 40/80/120W AUDIO AMPLIFIERS

DRIVECORE™ 

CSA240Z/280Z/2120Z 2 X 40/80/120W AUDIO AMPLIFIERS

By combining years of innovation, invention and insight from HARMAN brands, JBL® Commercial Series Amplifiers (CSA) go well beyond the expected in generating powerful sound. From the switch-mode universal power supply to the efficient performance of Crown's DriveCore's Technology, we continue to set new standards in commercial power amplifier technology.

Simple to configure, the CSA amplifiers provide a DriveCore-based sound solution. This replaces up to 500 parts with one small chip, significantly reducing the part count and increasing reliability while maintaining superb performance.

Supporting 70V and 100V installations out of the box, CSA amplifiers include RJ45 connectors for use with JBL CSR-V in-wall volume controls. Its universal power supply allows every CSA amp to accept AC voltages from 100 to 240 VAC, 50/60 Hz. And with HARMAN's GreenEdge™ environmental initiative, CSA amplifiers quickly pay for themselves in energy savings.



- 1 or 2 output channels with 40W, 80W, 120W per channel
- Built-in 70V and 100V
- Fanless, space-saving 1U design
- Sleep mode disable function
- Energy-efficient amplifier
- Sleek industrial look with illuminated rings making knobs easy to see and use
- Supports the JBL CSR-V wall controller via Ethernet cable
- Universal power supply

SPECIFICATIONS			
Model	Power Output (per channel)	Output Channels	Size
CSA140Z	40W	1	1U Half-Rack
CSA180Z	80W	1	1U Half-Rack
CSA1120Z	120W	1	1U Half-Rack
CSA240Z	40W	2	1U Half-Rack
CSA280Z	80W	2	1U Half-Rack
CSA2120Z	120W	2	1U Half-Rack

CSA-2120 2 X 120W AUDIO AMPLIFIER

A professional-grade, two-channel model, the CSA-2120 power amplifier provides simple analogue front-end processing. Delivering 2 x 120W at 4 and 8 ohms, this efficient, lightweight unit is convection-cooled and has an auto-standby mode to save energy.

The CSA-2120 is a professional-grade power amplifier built for commercial and installed sound applications. The amplifier is a two-channel model providing simple analogue front-end processing with a switch-mode universal power supply.

- Auto-standby mode for energy savings
- Balanced (Euroblock) and unbalanced (RCA) mono-summing inputs
- 1U lightweight design
- Plenum rated
- Over-heat auto protection
- Switch-mode universal power supply
- 2 x 120W at 4 and 8 ohms
- Compact size (1.75inH x 8.2inW x 9inD) Lightweight (under 4 lbs.)
- Optional Transformer Kit: CST-2120 for Hi-Z applications.

SPECIFICATIONS	
CSA Output Power	120W Per Channel
CSA Channels	2
CSA Sensitivity (8 ohms load)	1.4 Vrms
CSA Signal to Noise Ratio	>100dB
Weight & Size	1.3kg, 1U, Half Rack



CST-2120 70V/100V TRANSFORMER KIT

The JBL CST-2120 transformer module comes with a rack mounting kit so you can install it to a cabinet or wall. It supplies impedance and voltage matching from the CSA-2120 amplifier (with 4 and 8 ohms outputs) to drive 70V and 100V distributed speaker systems.

- Providing two channels for constant voltage operation
- 70V/100V Outputs
- Rack-mountable with CSA2120
- Detachable block input and output connectors.



Mixer/Amplifiers.

COMMERCIAL SERIES MIXER/AMPLIFIERS

Mixer/Amplifiers.

COMMERCIAL SERIES MIXER/AMPLIFIERS

VMA 160 / 1120 / 1240

COMMERCIAL MIXER AMPLIFIERS



The JBL VMA Series is a cost-effective line of Mixer/Amplifiers with low impedance functionality (4Ω, 8Ω) and high impedance 70V and 100V output. They are designed with convenient and flexible features to be used by commercial integrators worldwide.

- 5 inputs with 1 output of 60, 120, or 240W of power
- Independent bass and treble controls for each output channel
- 100V and 70V output, or 4Ω/8Ω
- Paging Chime, and Priority muting
- Works with JBL CSR-V wall controllers
- Balanced mic/line inputs; RCA (775V) inputs
- Rack mounting hardware included



SPECIFICATIONS				
Model	Power Output (per channel)	Inputs	Output Channels	Size
VMA160	60W	5	1	2U Full Rack
VMA1120	120W	5	1	2U Full Rack
VMA1240	240W	5	1	2U Full Rack

VMA 260 / 2120

COMMERCIAL MIXER AMPLIFIERS



The JBL VMA Series is a cost-effective line of Mixer/Amplifiers with low impedance functionality (4Ω, 8Ω) and high impedance 70V and 100V output. They are designed with convenient and flexible features to be used by commercial integrators worldwide.

- 8 inputs with 2 outputs of 60 or 120W of power
- Independent bass and treble controls for each output channel
- 100V and 70V output, or 4Ω/8Ω
- Paging Chime, and Priority muting
- Works with JBL CSR-V wall controllers
- Balanced mic/line inputs; RCA (775V) inputs
- Rack mounting hardware included



SPECIFICATIONS				
Model	Power Output (per channel)	Inputs	Output Channels	Size
VMA260	60W	8	2	2U Full Rack
VMA2120	120W	8	2	2U Full Rack

Mixer/Amplifiers.

COMMERCIAL SERIES MIXER/AMPLIFIERS

CSMA 180 / 1120 / 240 / 280 / 2120 COMMERCIAL MIXER AMPLIFIERS

Innovation is always evident throughout the JBL Commercial Series product lineup, and our new high-performance, energy-efficient Commercial Series Mixer-Amplifiers (CSMA) represents the latest example.

Manufactured using HARMAN's GreenEdge™ clean standards, including a low-energy powder coat that uses 33% less energy, CSMA units conform to lead-free RoHS standards. By incorporating Crown's exclusive DriveCore technology, they also deliver unsurpassed reliability, thermal management and power efficiency.

Offering unmatched ease of use and driving 8 ohm and 4 ohm loads, CSMA units include balanced mic/line inputs, unbalanced RCA inputs and speaker connections, and RJ45 connectors to use with JBL CSR-V in-wall volume controls.

DRIVECORE™



SPECIFICATIONS				
Model	Power Output (per channel)	Inputs	Output Channels	Size
CSMA180	80W	4	1	1U Half-Rack
CSMA1120	120W	4	1	1U Half-Rack
CSMA240	40W	8	2	1U Full-Rack
CSMA280	80W	8	2	1U Full-Rack
CSMA2120	120W	8	2	1U Full-Rack

- Fanless, space-saving 1U design
- Configurable output routing (2 channel only)
- Independent bass/treble controls for each output channel
- Euro-block type mic/line input and output connectors, and unbalanced RCA inputs for consumer connection
- Supports 70V and 100V distributed audio systems without needing a separate transformer
- Remote volume control capability using JBL CSR-V module and standard Ethernet cable
- Priority muting, VOX ducking, and phantom power for all models

Mixers.

COMMERCIAL MIXER & PUBLIC ADDRESS MIXER

Easily configured for a range of applications, such as background music, security, and paging, CSM units are designed for everything from schools and hospitals to restaurants and fitness facilities. They feature RJ45 connectors for use with JBL CSR-V in-wall volume controls, and a universal power supply that accepts AC voltages from 100 to 240 VAC, 50/60 Hz. Plus, they're built using HARMAN's GreenEdge™ clean standards to offer numerous energy-efficient benefits, including a lighter weight, space-saving design, and conforming to RoHS standards.

CSM-14 & CSM-28 COMMERCIAL MIXERS

The JBL® Commercial Series CSM-21 and CSM-32 Mixers offer a wide array of processing tools, including priority override, page ducking, source and zone EQ, and a built-in crossover.

Helping maintain optimum levels through the system, LevelGuard™ automatically applies the right amount of compression to the source signals based upon the incoming level.

AutoWarmth™ automatically adjusts the tonal balance within a zone based upon the zone output level, preventing music from sounding thin at lower levels or excessively resonant at higher levels.



- Fanless, space-saving 1U design
- Independent bass/treble controls
- Euro-block type mic/line input and output connectors, and unbalanced RCA inputs for consumer connection
- Sleek industrial look with illuminated rings making them easy to see and use
- Configurable output routing (2 channel models only)
- Supports JBL CSR-V wall controller via Ethernet cable
- Priority muting, VOX ducking, and phantom power for all models

SPECIFICATIONS			
Model	Inputs	Output Channels	Size
CSM-14	4	1	1U Half-Rack
CSM-28	8	2	1U Full-Rack

CSM-21 & CSM-32 PUBLIC ADDRESS MIXERS

The JBL® Commercial Series CSM-21 and CSM-32 Mixers offer a wide array of processing tools, including priority override, page ducking, source and zone EQ, and a built-in crossover.

Helping maintain optimum levels through the system, LevelGuard™ automatically applies the right amount of compression to the source signals based upon the incoming level.

AutoWarmth™ automatically adjusts the tonal balance within a zone based upon the zone output level, preventing music from sounding thin at lower levels or excessively resonant at higher levels.



SPECIFICATIONS									
Model	Stereo Source Inputs	Paging Microphone Input	Direct Input	Stereo Zone Outputs	Dedicated Subwoofer Output	Music-on-hold Output	Stereo/Mono Operation	Music Mute	Page Assign
CSM-21	2	Yes	Yes	1	Yes	-	Yes	Yes	Yes
CSM-32	3	Yes	Yes	2	Yes	Yes	Yes	Yes	Yes

Wall Controllers.

SOLID CONTROL AT YOUR FINGERTIPS

The JBL Commercial Series remote wall controllers offer source selection and/or volume control from an elegant user interface. Using Cat. 5 cable and installation-friendly RJ-45 connectors, the controllers can be placed up to 1000' (305m) from the CSM mixer.



HARMAN PROFESSIONAL TRAINING



CSR-V 1-ZONE WALL CONTROLLER

- Volume Control
- RJ-45 / Cat. 5 Connection
- Up to 1000' (305m) from CSM device
- For use with all CSMA, CSM, and CSA (Z) models
- Available in Black or White



CSR-2SV 2-ZONE WALL CONTROLLER

- Volume Control
- Source Selection (2 Sources)
- RJ-45 / Cat. 5 Connection
- Up to 1000' (305m) from CSM device
- For use with CSM-21 and CSM-32
- Available in Black or White

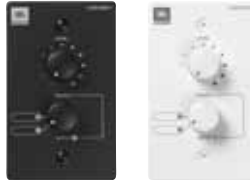

CSR-3SV 3-ZONE WALL CONTROLLER

- Volume Control
- Source Selection (3 Sources)
- RJ-45 / Cat. 5 Connection
- Up to 1000' (305m) from CSM device
- For use with CSM-32
- Available in Black or White



HARMAN PROFESSIONAL TRAINING

Take the time to upskill and expand your knowledge by leveraging the learning sessions on offer by HARMAN Professional Training. Facilitated by leading industry experts and HARMAN product specialists, HARMAN Professional Training provides the information, training on certifications needed to understand, sell, plan, design, install, program, and configure HARMAN Professional products and solutions accurately and effectively.

The training modules range from short bite-sized videos on specific products and technologies, through to face to face, instructor-led training, detailed webinars and certification courses. Whether you are just starting

your career in audio, or you are an industry professional looking to maintain or develop your qualifications, the Certification pathway is structured to suit you.

You can either follow the learning pathway from foundation learning through to examination, or you can jump straight to final examinations if you have the capability and confidence. Instructor-led courses which are eligible for 8 InfoComm / AVIXA RU Credits include HARMAN Pro Audio Designer and Audio Programmer (Audio Architect).

EXPLORE THE ALL NEW TRAINING PROGRAMME



VISIT WWW.HARMAN.REMOTE-LEARNER.NET/ TO DEVELOP YOUR LEARNING JOURNEY

CBT Calculator.

JBL's CBT Calculator software is a precision engineering tool allowing audio professionals to design JBL's CBT Constant Beamwidth Technology line array column loudspeakers into a wide variety of venues.

CBT Calculator shows the vertical coverage of CBT models in venues via a cross-sectional sound level coverage display. The program allows the use of up to 3 CBT speakers and virtual adjustment of their various adjustable settings for vertical coverage (narrow or broad) and voicing (speech or music/flat), in a space with up to 4 independent listening planes.

In addition to the SPL vertical coverage mapping of a proposed design, the CBT Calculator also shows the frequency response for up to 6 listener locations as well as an SPL summary of the listener locations over user-defined frequency bands.



It helps designers to determine the best CBT model selection, the proper vertical coverage and voicing settings, mounting height and the down-angle, allowing audio professionals to design CBT column line array speakers into many venue-application types.

VLA-C Calculator.

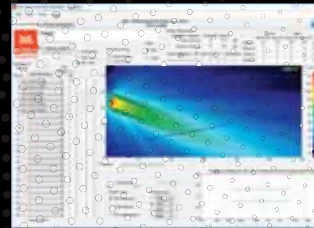

The free VLA-C Calculator is simulation software for designing and predicting JBL VLA-C Series systems.

The Acoustical Mapping tab allows for 2D sectional-view modeling of VLA-C arrays on up to four seating planes. Included are both patterns of the VLA-C full-range boxes (VLA-C285 and VLA-C2100) and the subwoofer (VLA-C125S). Mixed arrays may be modeled.

The Array Configuration tab describes the array and provides information about weight factors and centre of gravity (CG), along with mechanical validation of the array. The array weight design factor is selectable between 5:1, 7:1, and 10:1. Frame options are selectable. If the array configuration falls outside the load limits of either the speaker cabinets, the speaker interconnect system, or the suspension system, this will be indicated via an error indication. Array statistics like total weight, attach point span, and array height and depth are also calculated.

Ceiling Speaker Configurator (CSC) and Distributed System Design (DSD) Software

CSC is a general sales estimation tool for basic projects. It comes up with a few ideas about which ceiling speaker could be used and approximately how many. This free utility program helps select the most economical JBL ceiling speaker to use based on various characteristics of the project, based on desired music level (for music systems) or background noise level (for paging systems).

The intention is that the user will then model the project more completely in the DSD Distributed System Design software to determine how/whether the various possibilities from CSC might work for the project. DSD allows the user to change the design for "what if" scenarios: What will happen if we change the design to a different loudspeaker model, to a different tap setting, to a different density factor, etc? What happens if we trim the pendant speakers at a different height? What impact would different changes have on the number of speakers required, the layout distance between speakers, the resulting sound level, the level variation throughout the space, the required amplification, etc?



DDA (Digital Directivity Analysis).

DDA is a powerful yet intuitive Windows application for accurately predicting the electro-acoustic performance of loudspeaker systems in (semi) open or closed spaces. It includes 3D room acoustic modelling, direct sound simulation as well as statistical prediction of various acoustic parameters.

DDA supports all JBL point source loudspeakers with CLF data and all JBL Intellivox products. Intellivox makes use of JBL's advanced beam shaping (DDS) technologies. From DDA the radiation pattern of JBL Intellivox loudspeaker arrays can be controlled precisely and tailored to the shape and the acoustics of the space. In addition, DDA offers various design tools which reduce design time and help the sound designer to optimise the system performance. For installation and commissioning purposes DDA also generates FIR output filters which can be uploaded to supported DDS-controlled loudspeaker arrays using the JBL WinControl software.

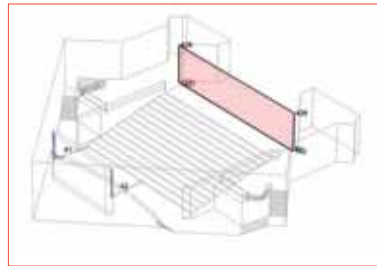



2023 Install Full Line Product Catalog



Find your local JBL representative: jblpro.com/en/distributors

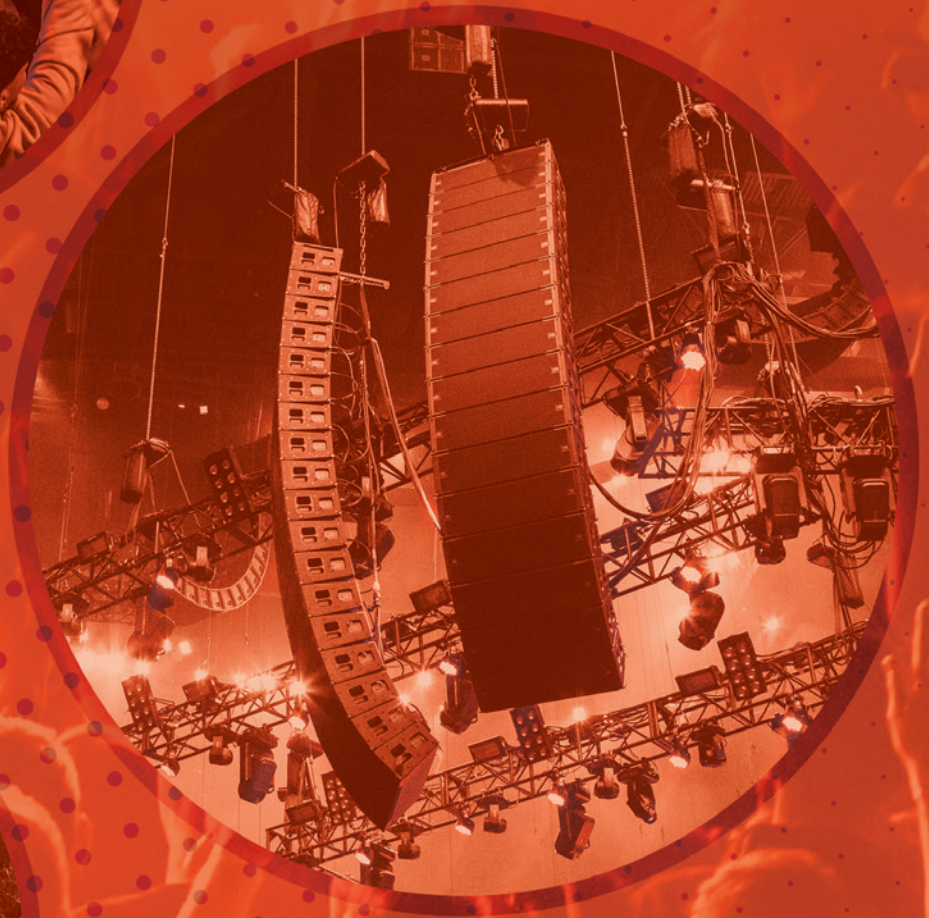

2023 Install Full Line Product Catalog

Contents

About JBL	4-7	JBL Pro Soundbar	29	Live Portable PA Speakers	68-78	JBL Commercial Series	89
Ceiling Loudspeakers	8-15	JBL Pro Soundbar.....	29	PRX400 Series.....	68-69	About JBL Commercial.....	89
CSS Commercial Series.....	8	Column Loudspeakers	30-33	EON700 Series.....	70-71	Commercial Series Amplifiers.....	90-91
8100 Series.....	9	CBT Series.....	30-32	PRX900 Series.....	72-73	Commercial Mixer/Amps.....	92-94
Control 10 Series.....	10-11	COL Series.....	33	SRX800 Series.....	74-75	Commercial Mixers.....	95
Control 20 Series.....	12	Beam Forming Columns	34-37	EON ONE Compact.....	76	Wall Controllers.....	96
Control 40 Series.....	13	Intellivox Series.....	34-37	EON ONE MKII.....	77	Training	97
Control 200 Series.....	14	Pointsource Loudspeakers	38-52	PRXONE.....	78	Software Tools	98-99
Control 300 Series.....	15	AE Application Engineered Speakers.....	38	Studio Monitors	79-80	CBT Calculator.....	98
Surface Mount Loudspeakers	16-22	About AE Pointsource Loudspeakers.....	39	3 Series MKII.....	79	CSC and DSD Software.....	98
Control Contactor 20 Series.....	16-17	AM Speakers.....	40	7 Series.....	80	VLA-C Calculator.....	99
CSS Commercial Series.....	18	AE Subwoofers.....	41-42	Cinema Speakers	81-88	DDA.....	99
Control 50 Series.....	19	AE Expansion Series.....	43-44	200 Series.....	81		
Control Pro Series.....	20	AE Compact Loudspeakers.....	45	Screen Array 3-way.....	82		
Control CRV Series.....	21	All Weather Compact Series.....	46	High Power Screen Arrays.....	83		
Control HST Series.....	22	AW All Weather Series Full Size.....	47-48	Surround Systems.....	84-85		
Pendant Loudspeakers	23-24	CWT Series.....	49	Cinema Subwoofers.....	86		
Control 60 Series.....	23-24	PD500 Series.....	50	Cinema Amplifiers.....	87		
In-wall Loudspeakers	25	PD6000 Series.....	51	CPI 2000 Processor.....	88		
Control 100 Series.....	25	PD700i Series.....	52				
Landscape Loudspeakers	26	Installed Audio	53-67				
Control 80 Series.....	26	VLAi Series.....	53				
GSF Series.....	27	VLA Compact Series.....	54-55				
GSB Series.....	28	VRX900 Series.....	56-57				
		VTX A-Series.....	58-59				
		VTX V-Series.....	60-61				
		VTX-F Series.....	62				
		VTX-M Series.....	63				
		VTX Subwoofers.....	64-65				
		SRX900 Series.....	66-67				

Contact Us

For more information on JBL Professional Loudspeakers and Commercial Audio products for your next project visit us at www.jblpro.com



About JBL.

Power And Versatility Are Just The Beginning.

When it comes to innovating audio, JBL Professional never ceases to raise the bar. Since our inception more than 75 years ago, our brand has become synonymous with epic sound. And while the enjoyment is instinctive, the science behind each innovation is precise and methodical. Passionate and gifted engineers and designers around the world devote themselves to developing JBL products and solutions that take listening to the next level—and they've been striving for those goals since day one.



JBL Professional solutions encompass recording studios, movie theatres, tour sound, installed sound, arenas and stadiums, hospitality venues, houses of worship and much more. At the heart of each solution are a meticulous attention to detail, a drive to develop everything from the ground up, and an unwavering dedication to giving music makers outstanding sound, whether they're performing at a major music festival or busking on a street corner. The technologies that we develop for professionals benefit all audiophiles and music fans as we distill them into compact form factors, letting both content creators and listeners enjoy professional-quality sound in convenient, easy to-use tools and at affordable prices.



Over the decades, JBL has pioneered a remarkable number of engineering firsts and innovations that cemented our reputation as an industry leader, garnering Grammy® Awards, Academy Awards, and accolades from the world's most celebrated musicians and customers alike along the way.



Fusing a bold vision of the future with the extraordinary passion and talent of our engineers and designers, we develop our own solutions, invent our own technologies, and create our own tools, with a pioneering spirit that has defined the brand for more than seven decades. Today, JBL is in more than 130 countries, encompasses an increasingly diverse range of next-level products and solutions, and has more than 300 patents to our name, for groundbreaking technologies like the VGC™ transducer, Slip Stream™ low-frequency port, Progressive Transition™ (PT) waveguide and Plus One™ woofer cone.

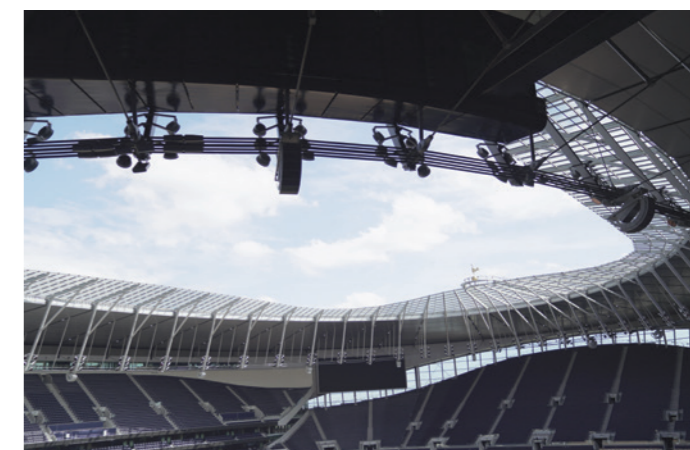

Thanks to our enduring dedication to surpassing customer expectations, JBL sound has become part of the fabric of people's lives. Whether it's cinema sound that delivers more immersive movie-going experiences, soundbars that transform living rooms into concert halls, portables that let listeners enjoy their favorite tunes wherever they go, gaming headsets that make players swear they've stepped inside the action, or in-car audio technology that transforms daily commutes into moments of pure listening pleasure, JBL fills listeners' lives with sound as it was meant to be heard.

A Journey of Engineering Excellence.

JBL

PROFESSIONAL

Audio technology is at the core of everything JBL does. For more than 75 years, we've employed the best methodologies and tools, developing everything from the ground up, guaranteeing our efforts exceed the needs and expectations of audio professionals throughout the world. Never straying from this exacting formula, we've produced a prolific list of audio achievements, groundbreaking technologies, and revolutionary advances in the art and science of professional audio, earning many patents and awards along the way. It's a journey that is legendary worldwide and has positioned JBL as the world leader in professional audio—not just as a brand, but as a company known for continually blending creativity and science as a manifestation of our passion for sound and commitment to those who create it.



Directivity.

Building better loudspeaker components is the first of many performance challenges that face audio design engineers. But controlling the sound as it leaves the speaker enclosure is just as critical to system performance. The goal is always the same: Deliver a consistent dispersion pattern throughout desired vertical and horizontal planes without introducing artifacts, while ensuring a seamless transition between high-frequency and low-frequency components. JBL engineers relentlessly refine new enclosure designs and innovate materials that deliver optimal performance, often inventing testing methodologies that leave no stone unturned in their thorough and rigorous design evaluation. Our pioneering methods have led to such groundbreaking designs as the Progressive Transition Waveguide, Image Control Waveguide, Slip Stream Port, Radiation Boundary Integrator, and Constant Curvature Waveguide. Proven in the real world with successful installations around the globe, JBL technology continues to evolve through our continuous pursuit of the best, most accurate sound.

Transducers.

The JBL engineering legacy began in transducer technology. Building on our founder James B. Lansing's historic foundation, JBL engineers continue to break ground on new and better ways to design transducers, reaching beyond the "possible" and consistently setting new performance benchmarks for the audio industry. Designing products from the ground up has led to us innovating technologies such as Differential Drive woofers, CMCD Cone Midrange drivers, and the D2 Dual Voice Coil Compression Driver, that cover the entire range of professional audio tools. Addressing performance-robbing challenges in power compression, heat dissipation, distortion, component weight, and physical footprint, we've developed a range of transducers that are unparalleled in their ability to deliver extraordinary performance in a wide range of applications.



DIFFERENTIAL DRIVE®

JBL's exclusive dual-voice coil, dual-magnetic-gap Differential Drive technology reduces speaker weight while enhancing critical performance attributes including better heat dissipation, lower power compression and higher dynamic range, compared to conventional single-coil designs. The result is very high output with minimal power compression and deep, distortion-free bass even at very high SPLs. Differential Drive technology is at the core of a range of woofer models incorporated in JBL loudspeaker systems supporting touring, fixed installations, recording studios and cinemas.



D2 DUAL DIAPHRAGM DUAL VOICE COIL COMPRESSION DRIVER

The revolutionary D2 Dual Diaphragm Dual Voice Coil Compression Driver dramatically improves high-frequency performance, offering an extreme output advantage over conventional systems, with significantly higher array power and reduced distortion, thanks to double the number of voice coils and more than double the power handling. This results in a dramatic increase in pure high-frequency sound pressure levels with a 30-percent reduction in weight in the same physical footprint.



DUAL DIAPHRAGM
DUAL VOICE COIL
COMPRESSION DRIVER

FEATURING
D2



RADIATION BOUNDARY INTEGRATOR™ (RBI)

JBL's patented Radiation Boundary Integrator combines a large-diameter high-frequency waveguide with low-frequency projection apertures that work in tandem to ensure the transition across each band is uninterrupted, undistorted, and seamless. A patented, tuned resonant chamber is integrated into the waveguide itself, effectively eliminating throat-related cancellations due to back pressure from the mid-range section. Our refined RBI waveguide implementation delivers improved horizontal coverage—broader and more stable.



Testing.

All audio products have a useful life, and JBL engineers are committed to making your investment last as long as possible—not only in terms of reliability, but in terms of how great your system sounds every time you turn it on. Every JBL Professional product undergoes stringent testing above and beyond the conditions products face when deployed in the real world.



JBL research facilities feature multiple application-specific anechoic testing chambers and showcase our "Speaker Shuffler"—the only one of its kind—which allows rapid and precise re-positioning of speaker systems in the exact same precise position, for unrivaled accuracy in A/B testing. Our rigorous, uncompromising testing methodologies result in continuous performance breakthroughs and ensure that JBL customers worldwide can always work with confidence.

CEILING SPEAKERS



Grande Centre Point, Thailand

CSS Commercial Series.

ENTRY-LEVEL BACKGROUND MUSIC AND PAGING SPEAKERS

The JBL CSS Commercial Series provides affordable performance for paging and background music applications in retail stores, restaurants, schools and other facilities.

CSS8004 100mm (4IN) COMMERCIAL SERIES CEILING SPEAKERS

The CSS8004 is a 100mm (4in) speaker with 90dB sensitivity and a 5-Watt multi tap transformer. The speaker's triple-voltage transformer provides versatility by allowing use on 100V, 70V, or 25V distributed loudspeaker lines. Available in White.

- Transducer: 100mm
- Dispersion: 175° Conical
- Response: 85Hz-18kHz
- Sensitivity: 90dB
- Power: 15W 8Ω (5W Tx)



CSS8008 200mm (8IN) COMMERCIAL SERIES CEILING SPEAKERS

The CSS8008 is a 200mm (8in) speaker with 96dB sensitivity and a 5-Watt multi tap transformer. The speaker's triple-voltage transformer provides versatility by allowing use on 100V, 70V, or 25V distributed loudspeaker lines. Available in White.

- Transducer: 200mm
- Dispersion: 120° Conical
- Response: 55Hz-16kHz
- Sensitivity: 96dB
- Power: 15W 8Ω (5W Tx)



CSS8018 200mm (8IN) COMMERCIAL SERIES CEILING SPEAKERS

The CSS8018 is a high-powered 200mm (8in) speaker with 97dB sensitivity and a 10-Watt multi tap transformer. The speaker's triple-voltage transformer provides versatility by allowing use on 100V, 70V, or 25V distributed loudspeaker lines. Available in White.

- Transducer: 200mm
- Dispersion: 110° Conical
- Response: 50Hz-17kHz
- Sensitivity: 97dB
- Power: 20W 8Ω (10W Tx)



CSS15C-VA 127mm (5IN) CEILING LOUDSPEAKER FOR EN54-24 APPLICATIONS

A full-range, EN54-24 certified ceiling speaker consisting of a 127mm (5in) full-range dual-cone driver, torsion-mounted into an included easy-install blind-mount metal fire dome. The speaker is designed to provide clear and intelligible sound for applications requiring EN54 certification and/or BS5839 compliance. Available in White.

- Transducer: 125mm
- Dispersion: 120° Conical
- Response: 180Hz-20kHz
- Sensitivity: 92dB
- Power: 6W Tx



8100 Series.

SCULPTED GRILLE DUAL-CONE CEILING SPEAKERS

High sensitivity at a cost-effective price point, the 8100 Series is an easy to install loudspeaker solution for a wide variety of commercial sound applications. With its contemporary grille design, the 8100 Series loudspeakers are ideal for a variety of settings ranging from restaurant and retail settings to professional offices and reception areas. All models feature 6W transformer for 70V/100V distributed lines.

8124 100mm (4IN) FULL-RANGE, IN-CEILING LOUDSPEAKER

The 8124 is a 100mm (4in), full-range, loudspeaker, featuring a high sensitivity driver that provides 130° conical coverage in a lightweight 1.2kg package and includes dog-ears for easy blind mount installations. Available in White.

- Transducer: 100mm
- Dispersion: 130° Conical
- Response: 60Hz-18kHz
- Sensitivity: 93dB
- Power: 20W 8Ω (6W Tx)



8128 200mm (8IN) FULL-RANGE, IN-CEILING LOUDSPEAKER

The 8128 is a 200mm (8in), full-range loudspeaker featuring a high sensitivity driver that provides 90° conical coverage in a lightweight 1.4kg package and includes dog-ears for easy blind mount installations. Available in White.

- Transducer: 200mm
- Dispersion: 90° Conical
- Response: 50Hz-16kHz
- Sensitivity: 97dB
- Power: 25W 8Ω (6W Tx)



The 8124 and 8128 Ceiling Speakers are designed with built-in dog-ears for fast and easy installations, and are lightweight with open-back design for applications not requiring an in-ceiling backcan.

8138 200mm (8IN) FULL-RANGE, IN-CEILING LOUDSPEAKER

The 8138 is a 200mm (8in), full-range loudspeaker designed for use with MTC-81BB8 pre-install in-ceiling backcan, resulting in high sensitivity performance at a cost effective price point. Available in White.

- Transducer: 200mm
- Dispersion: 90° Conical
- Response: 95Hz-18kHz
- Sensitivity: 97dB
- Power: 25W 8Ω (6W Tx)



ACCESSORIES

Because of the very light weight of 8124 and 8128, tile rails may not be required for some in-ceiling applications. They are not packaged with these models, however MTC-RAIL tile rail sets and MTC-8124C and MTC-8128C C-rings are available separately.



The 8138 is designed for use with MTC-81BB8 backcan and MTC-81TB8 tile bridge.

Control 10 Series.

AFFORDABLE BLIND-MOUNT CEILING SPEAKERS

Control 10 Series in-ceiling loudspeakers meet the increased market demand for superior sound quality, installation-friendly features and value, delivering a level of sonic performance unmatched by comparably priced products. They are ideal for applications where excellent sound quality is needed for medium-volume music playback and paging.

Control 10 Series models feature wide bandwidth, wide coverage, and combined 70V/100V and 8 ohm operation in each speaker. Dual conduit clamp allows separate strain reliefs for the input and loop out cables. High humidity grilles are available to suit Control 12, 14 and 16 models.



Toyota Buzz Vibhavadi Headquarters, Thailand

CONTROL 12C/T

76mm (3IN) COMPACT CEILING LOUDSPEAKER

The Control 12C/T is a high fidelity speaker with a 76mm (3in) full-range driver and a wide frequency range of 68Hz to 17kHz. The short 120mm (4.7in) blind-mount backcan allows for easy installation in shallow ceiling spaces. Available in Black or White.

- Transducer: 76mm
- Dispersion: 130° Conical
- Response: 95Hz-15kHz
- Sensitivity: 84dB
- Power: 20W 8Ω (15W Tx)



Also available: Control 12C-VA – EN54-24 Certified for life safety applications

CONTROL 14C/T

100mm (4IN) TWO-WAY COAXIAL IN-CEILING LOUDSPEAKER

The Control 14C/T contains a co-axially mounted 100mm (4in) woofer and 19mm (3/4in) soft dome tweeter. The liquid-cooled soft dome tweeter provides clear, pleasant sound over a wide coverage area. Blind-mount backcan for quick and easy installation. Available in Black or White.

- Transducer: 100mm+19mm
- Dispersion: 120° Conical
- Response: 74Hz-20kHz
- Sensitivity: 87dB, D, WG
- Power: 30W 8Ω (25W Tx)



Also available: Control 14C-VA – EN54-24 Certified for life safety applications

CONTROL 16C/T

165mm (6.5IN) TWO-WAY COAXIAL IN-CEILING LOUDSPEAKER

Control 16C/T is a full-range ceiling speaker consisting of a 165mm (6.5in) high tech cone driver and a 19mm soft-dome liquid cooled tweeter mounted in a vented, paintable baffle made of UV resistant UL94-V0 and UL94-5HB material, with a pre-attached blindmount backcan for quick and easy installation. Available in Black or White.

- Transducer: 165mm+19mm
- Dispersion: 110° Conical
- Response: 62Hz-20kHz
- Sensitivity: 91dB, D, WG
- Power: 50W 8Ω (30W Tx)



Also available: Control 16C-VA – EN54-24 Certified for life safety applications

CONTROL 18C/T

200mm (8IN) TWO WAY COAXIAL CEILING LOUDSPEAKER

Control 18C/T is a full-range ceiling speaker consisting of a 200mm (8in) high tech cone driver and a 25mm soft-dome liquid cooled tweeter mounted in a vented, paintable baffle made of UV resistant UL94-V0 and UL94-5HB material, with a pre-attached blind-mount backcan for quick and easy installation. The speaker is designed to provide excellent sound quality for a wide variety of medium to high volume applications. Available in Black or White.

- Transducer: 200mm+25mm
- Dispersion: 90° Conical
- Response: 58Hz-20kHz
- Sensitivity: 92dB, D, WG
- Power: 90W 8Ω (60W Tx)



ACCESSORIES

- New Construction Brackets & Trim Rings: The Control 10 Series speaker utilises the Control 20 Series NC New Construction Brackets, MR Plaster Ring Brackets, and TR Trim Rings.
- Control 12C/T and 14C/T utilise MTC-24NC, MR & TR
- Control 16C/T utilises MTC-26NC, MR & TR
- MTC-48TRx12: Tile Rails for (4' x 4') ceiling tiles (pack of 12 rails)

- High Humidity Grilles:
- MTC-14WG (White) fits Control 12C/T and 14C/T
 - MTC-14WG-BK (Black) fits Control 12C/T-BK and 14C/T-BK
 - MTC-16WG (White) fits Control 16C/T
 - MTC-16WG-BK (Black) fits Control 16C/T-BK

Control® Contractor 20 Series.

PREMIUM SMALL-FORMAT CEILING SPEAKERS

JBL Control Contractor 20 Series small-format ceiling speakers provide full-range, high-fidelity sound reinforcement for background music and music-plus-paging systems. Innovative features like titanium-coated tweeters and JBL's proprietary diffraction-horn loading technology deliver extremely wide, even coverage, meaning fewer speakers are required for any installation. Models are packaged as complete assemblies including grille, backcan and tile rails, and can be installed without accessing areas above the ceiling. All speakers feature JBL's exclusive SonicGuard™ overload protection, enabling higher operational levels and improving reliability. Control Contractor 20 Series ceiling speakers are voiced similarly to other JBL Control Contractor models, allowing them to be combined with in-wall and surface-mount speakers in a single listening space.

CONTROL 24C MICRO, 24CT MICRO & 24CT MICROPLUS 115mm (4.5in) BACKGROUND MUSIC CEILING LOUDSPEAKER

The Control 24C/CT Micro AND 24CT MicroPlus are compact and easy to install in-ceiling speakers providing full, high quality sound for background music and music-plus paging systems. The 24CT Micro includes a 9W multi-tap transformer and the 24CT MicroPlus includes a 25W multi-tap transformer. Available in White.

- Transducer: 115mm+12mm
- Dispersion: 150° (Asym)
- Response: 85Hz-25kHz (Control 24CT Microplus 80Hz-25kHz)
- Sensitivity: 86dB, D
- Power: 15W 8Ω C / 9W Tx CT (Control 24CT Microplus: 25W Tx)



CONTROL 24C, 24CT & 24CT-BK 100mm (4in) BACKGROUND/FOREGROUND CEILING LOUDSPEAKER

The Control 24C contains a coaxially mounted 4in woofer and 3/4in titanium coated tweeter providing high fidelity sound over a wide coverage area. The 24CT provides a 70V/100V multi-tap transformer. The 24CT is available in Black (C24CT-BK).

- Transducer: 115mm+19mm
- Dispersion: 130° Conical
- Response: 80Hz-20kHz
- Sensitivity: 86dB, D, WG
- Power: 40W 16Ω C / 30W Tx CT



CONTROL 26C, 26CT & 26CT-LS 165mm (6.5in) BACKGROUND MUSIC CEILING LOUDSPEAKER

The Control 26C contains a coaxially mounted 165mm (6.5in) woofer and 3/4in titanium coated tweeter, able to deliver maximum sound level over a defined area. The 26CT provides a 70V/100V multi-tap transformer. The 26CT-LS is UL1480/UUMW life-safety certified. Available in White.

- Transducer: 165mm+19mm
- Dispersion: 110° Conical
- Response: 75Hz-20kHz / 80Hz-20kHz -LS
- Sensitivity: 89dB, D, WG
- Power: 75W 16Ω C / 60W Tx CT, -LS



CONTROL 26-DT 165mm (6.5in) COAXIAL CEILING SPEAKER

The Control 26-DT is a compact ceiling speaker assembly configured to install into standard ceiling backcans designed for 200mm (8in) drivers. Available in Black.

- Comes complete with transducer, network and transformer
- Transducer: 165mm+19mm
- Dispersion: 90° Conical
- Response: 70Hz-20kHz
- Sensitivity: 89dB, D, WG
- Power: 60W Tx



CONTROL 19CS & 19CST 200mm (8in) IN-CEILING SUBWOOFER

The Control 19CS uses advanced proprietary technologies to produce powerful bass from a low profile in-ceiling design. The optional 19CST has a special subwoofer band transformer for 70V/100V operation. Available in White.

- Transducer: 200mm
- Response: 42Hz-200Hz
- Sensitivity: 95dB
- Power: 100W 8Ω CS / 75W Tx CST



ACCESSORIES

- New Construction Bracket: MTC-xxNC* · Plaster Ring Bracket: MTC-xxMR*
- Trim Rings: Allow for installation into existing ceiling speaker cutouts that are larger than the speaker's normal cutout size. MTC-xxTR*
- MTC-48TRx12: Tile Rails for 4' x 4' ceiling tiles (pack of 12 rails)
- High humidity grille MTC-16WG (white) fits Control 26C and 26CT.

*These models are available in different sizes. Specify speaker model when ordering.

Control® 40 Series.

EXTENDED PERFORMANCE SMALL-FORMAT CEILING SPEAKERS WITH CONICAL RBI

The Control 40 Series Ceiling Speaker are designed to work perfectly in environments that require a premium, in-ceiling speaker with an extremely wide bandwidth and consistent coverage. Consisting of three 165mm (6.5in) coaxial models, a 60mm (2.5in) ultra-compact satellite speaker and in-ceiling subwoofer, the Control 40 Series can be configured in many different ways to accommodate a full range of applications. JBL focused on ease-of-installation by including an integrated backcan, grille and tile rails (except Control 42C), locking 2-pin connectors and two knockouts. The Control Series speakers are designed for use in air handling spaces.

CONTROL 42C 60mm (2.5in) ULTRA COMPACT SATELLITE SPEAKER

The Control 42C is an ultra-compact in-ceiling satellite loudspeaker designed for use with the Control 40CS/T subwoofer. It offers an unobtrusive design which is ideal for a wide range of installations. Available in White.

- Transducer: 50mm
- Dispersion: 150° Conical
- Response: 140Hz-20kHz
- Sensitivity: 82dB
- Power: 15W 16Ω



CONTROL 45C/T 130mm (5.25in) COAXIAL CEILING RBI™ LOUDSPEAKER

The Control 45C/T is a premium loudspeaker designed for applications that can benefit from extremely wide bandwidth and very consistent coverage from a ceiling speaker with a small footprint. Available in White.

- Transducer: 130mm+20mm
- Dispersion: 120° Conical
- Response: 55Hz-20kHz
- Sensitivity: 88dB, D, WG
- Power: 75W 8Ω (60W Tx)



CONTROL 47C/T & 47LP 165mm (6.5in) COAXIAL CEILING RBI™ LOUDSPEAKER

The Control 47C/T and Control 47LP are designed for applications that require extremely wide bandwidth and very consistent coverage. The Control 47LP (Low Profile backcan) is identical to Control 47 but equipped with a shallow backcan for use in areas with restricted mounting depths. Available in White.

- Transducer: 165mm+25mm
- Dispersion: 120° Conical
- Response: 55Hz-20kHz / 68Hz 47LP
- Sensitivity: 91dB, D, WG
- Power: 75W 8Ω (60W Tx)



CONTROL 47HC 165mm (6.5in) COAXIAL HIGH CEILING RBI™ LOUDSPEAKER

The Control 47HC is designed for applications that require a narrow focused beamwidth pattern and very consistent coverage, such as for increasing clarity, intelligibility and SPL when in high-ceiling applications. Available in White.

- Transducer: 165mm+25mm
- Dispersion: 75° Conical
- Response: 55Hz-17kHz
- Sensitivity: 93dB, D, WG
- Power: 75W 8Ω (60W Tx)



CONTROL 40CS/T 200mm (8in) HIGH IMPACT CEILING SUBWOOFER

The Control 40CS/T is a direct radiating, high impact 8in subwoofer designed for powerful bass response in an in-ceiling loudspeaker. It features a built in crossover network and four high-passed outputs enabling it to be used as a sub/sat system. Available in White.

- Transducer: 200mm
- Response: 32Hz-300Hz
- Sensitivity: 89dB
- Power: 100W 8Ω (80W Tx)



ACCESSORIES

- New Construction Bracket: MTC-xxNC* · Plaster Ring Bracket: MTC-xxMR*
- Trim Rings: Allow for installation into existing ceiling speaker cutouts that are larger than the speaker's normal cutout size. MTC-xxTR*
- MTC-48TRx12: Tile Rails for 4' x 4' ceiling tiles (pack of 12 rails).

*These models are available in different sizes. Specify speaker model when ordering.

Control® 200 Series. MEDIUM-FORMAT CEILING SPEAKERS

Control 226C/T, 227C and 227CT are premium in-ceiling speakers designed to meet the increasing market demand for premium quality sound in ceiling-mount applications. The Control 200 Series loudspeakers incorporate breakthrough performance features such as best-in-class pattern control to provide a consistent sound throughout the listening area. Especially wide coverage allows fewer speakers to cover the space, reducing both the material and labor cost for the installation. The high-power kevlar-reinforced 6.5in (165mm) low-frequency driver along with the titanium-diaphragm compression driver and the advanced-technology steep-slope crossover provide superb, wide-bandwidth sound quality.



CONTROL 226C/T

Control 200 models are available both in an independent backcan design (Control 227C & 227CT) and in an integrated backcan version (Control 226C/T).

CONTROL 226C/T 165mm (6.5in) COAXIAL CEILING LOUDSPEAKER WITH HF COMPRESSION DRIVER

Control 226C/T is a compact, easy-to-install speaker with integrated backcan for blind-mounting into ceilings. It features a top-quality 60W multi-tap transformer for 70V/100V line distribution systems. The transformer may be bypassed, allowing the Control 226C/T to be used as a low-impedance 8 ohm speaker. C-ring, tile rails and grille are included. This model is designed to be able to utilise the optional MTC-19NC new construction ring and MTC-19MR plaster-ring for new construction projects requiring pre-installation rings. Available in White.

- Transducer: 165mm+25mm
- Dispersion: 120° Conical
- Response: 47Hz-19kHz
- Sensitivity: 90dB, CD
- Power: 100W 8Ω (68W Tx)



CONTROL 227C & 227CT 165mm (6.5in) COAXIAL CEILING LOUDSPEAKER WITH HF COMPRESSION DRIVER

Control 227C is a high-output, low-impedance 8 ohm speaker assembly for installation with the separate MTC-200BB8 backcan and MTC-RG6/8 grille (both sold separately). Optional accessories include MTC-19NC new construction ring, MTC-19MR plaster-ring, and MTC-TB6/8 tile bridge. Control 227CT is a 70V/100V version of Control 227C, featuring a top-quality 60W multi-tap transformer for 70V/100V line distribution systems.

- Transducer: 165mm+25mm
- Dispersion: 120° Conical
- Response: 43Hz-19kHz
- Sensitivity: 90dB, CD
- Power: 100W 8Ω C / 68W Tx CT



ACCESSORIES

- MTC-200BB8: Backcan for Control 227C and 227CT. 337mm (13.3in) max diameter x 206mm (8.1in) deep
- MTC-RG6/8: Round grille for Control 227C and 227CT. Also fits Control 328C & 328CT. 345mm (13.6in) in diameter
- MTC-SG6/8: Square grille for Control 227C and 227CT. Also fits Control 328C & 328CT. 340mm (13.4 in) x (340 mm)
- MTC-TB6/8: Tile bridge for Control 227C and 227CT. Also fits Control 328C & 328CT.
- MTC-19NC & MTC-19MR: New-construction and mud rings fit Control 226 for new construction applications requiring pre-installation rings.

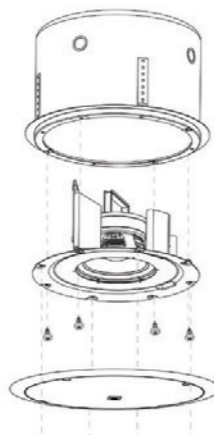

CONTROL 227C & 227CT

Assembly with backcan and grille.

Control® Contractor 300 Series LARGE-FORMAT CEILING SPEAKERS

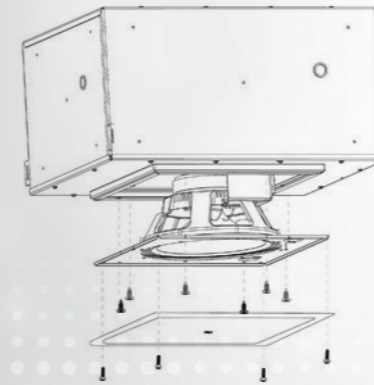

Control 300 Series represents the state of the art in large-format ceiling loudspeaker systems. True point-source coax designs, multiple power levels and transformer choices, plus an in-ceiling subwoofer, make it easy to fulfill any system performance requirements. Premium components include Kevlar-reinforced cones, low-saturation transformers and legendary JBL compression drivers. Advanced high-slope crossover networks, combined with low system distortion and smooth frequency response provides full, natural music along with exceptional speech intelligibility.

CONTROL 328C & 328CT 200mm (8in) COAXIAL CEILING LOUDSPEAKER WITH HF COMPRESSION DRIVER

The Control 328C has a 8in woofer and 1in compression driver engineered from the ground up to deliver exceptional performance in a coaxial point source design ceiling speaker. The optional Control 328CT includes 70V/100V multi-tap transformer.

- Transducer: 200mm+25mm
- Dispersion: 100° Conical
- Response: 45Hz-18kHz
- Sensitivity: 93dB, CD
- Power: 150W 8Ω C / 68W Tx CT



CONTROL 321C & 321CT 300mm (12in) COAXIAL CEILING LOUDSPEAKER WITH HF COMPRESSION DRIVER

The Control 321C has a 12in woofer and 1in compression driver engineered from the ground up to deliver exceptional performance in a coaxial point source design ceiling speaker. The optional Control 321CT includes 70V/100V multi-tap transformer.

- Transducer: 300mm+25mm
- Dispersion: 90° Conical
- Response: 34Hz-18kHz
- Sensitivity: 94dB, CD
- Power: 200W 8Ω C / 68W Tx CT



CONTROL 322C & 321CT 300mm (12in) HIGH OUTPUT COAXIAL CEILING SPEAKER

The Control 322C has a high output 12in woofer and 1in compression driver engineered from the ground up to deliver exceptional performance in a coaxial point source design ceiling speaker. The optional Control 322CT includes 70V/100V multi-tap transformer.

- Transducer: 300mm+37mm
- Dispersion: 90° Conical
- Response: 32Hz-20kHz
- Sensitivity: 95dB, CD
- Power: 250W 8Ω C / 100W Tx CT



CONTROL 312CS 300mm (12in) HIGH OUTPUT IN-CEILING SUBWOOFER SPEAKER

The Control 312CS is a high output 12in subwoofer that is an excellent addition to JBL Control 321, 322, and 328 loudspeaker systems.

- Response: 30Hz-4kHz
- Sensitivity: 93dB
- Power: 250W 8Ω



ACCESSORIES

Premium accessories include best-in-class black boxes made of heavy 16 gauge metal and lined with 1/2 MDF, as well as contemporary grilles and an optional higher power transformer. A variety of grilles are available.

SURFACE-MOUNT SPEAKERS



Indeogwon Catholic Church, South Korea

Control Contractor 20 Series. SURFACE-MOUNT SPEAKERS

JBL Control Contractor 20 Series surface-mount speakers and subwoofers deliver full, rich sound; deep bass extension; high SPL output; and wide, consistent coverage for retail stores, restaurants, health clubs, theme parks, educational facilities or any application demanding top-quality sound reinforcement in a rugged, compact package.

Built-in JBL Invisiball® mounting technology makes installation a breeze. Outdoor capabilities can be further enhanced with optional IP55 WeatherMax™ grilles. Control Contractor surface-mount speakers are voiced similarly to other JBL Control Contractor models, allowing them to be combined with in-wall and in-ceiling speakers in a single listening space. The Control Contractor 20 line balances superior fidelity with versatility, ease-of-installation and contemporary style: Models feature IP44 weather-resistant transducers and enclosures.



CONTROL 23-1 ULTRA-COMPACT INDOOR/OUTDOOR BACKGROUND/FOREGROUND SPEAKER

The Control® 23-1 is a two-way 3in speaker with rich sonic character, wide coverage, consistent dispersion, versatile mounting, and a contemporary high-design look that fits into a wide range of decors. Available in Black or White. Also available: Control 23-1L - 8 ohm only

- Dispersion: 100°x 100° HxV
- Response: 70Hz-20kHz
- Sensitivity: 86dB, D, WG
- Power: 40W 8Ω (15W Tx)
- Environmental: IP-44



CONTROL 25-1 COMPACT INDOOR/OUTDOOR BACKGROUND/FOREGROUND SPEAKER

The Control® 25-1 is a two-way 5in speaker with rich sonic character, wide coverage, consistent dispersion, versatile mounting, and a contemporary high-design look that fits into a wide range of decors. Available in Black or White. Also available: Control 25-1L - 8 ohm only

- Dispersion: 100°x 100° HxV
- Response: 60Hz-20kHz
- Sensitivity: 90dB, D, WG
- Power: 75W 8Ω (30W Tx)
- Environmental: IP-44



CONTROL 28-1 HIGH-OUTPUT INDOOR/OUTDOOR BACKGROUND/FOREGROUND SPEAKER

The Control® 28-1 is a two-way 8in speaker with rich sonic character, wide coverage, consistent coverage, versatile mounting, and a contemporary high-design look that fits into a wide range of decors. Available in Black or White. Also available: Control 28-1L - 8 ohm only

- Dispersion: 100°x 100° HxV
- Response: 45Hz-20kHz
- Sensitivity: 91dB, D, WG
- Power: 90W 8Ω (60W Tx)
- Environmental: IP-44



CONTROL 25-AV & 25-AVLS COMPACT BACKGROUND/FOREGROUND SPEAKER

The Control 25 is an especially wide band-width, smooth response speaker. It features a top quality 70V/100V transformer for distribution systems which can also be bypassed for use as an 8 ohm speaker. The Control 25AV-LS is UL1480 UUMW listed for use in fire alarm and/or emergency communication systems. Also EN52-24 certified. Available in Black or White.

- Dispersion: 100°x 100° HxV
- Response: 70Hz-23kHz
- Sensitivity: 87dB, D, WG
- Power: 100W 8Ω (60W Tx)
- Environmental: IP-X4



CONTROL 29AV-1 PREMIUM INDOOR/OUTDOOR MONITOR SPEAKER

The Control 29AV-1 utilises high power components and a complex network to achieve smooth high fidelity performance and a well-controlled defined coverage from a compact loudspeaker. Available in Black or White.

- Dispersion: 110°x85° HxV
- Response: 37Hz-18kHz
- Sensitivity: 90dB
- Power: 150W 8Ω (110W Tx)
- Environmental: IP-X4



CONTROL 30 3-WAY HIGH OUTPUT INDOOR/OUTDOOR MONITOR SPEAKER

The Control 30 is a three-way high output speaker designed for multiple uses. Weather resistance has been maximised, making the Control 30 suitable for outdoor applications. Includes 70V/100V multi-tap transformer. Available in Black or White.

- Dispersion: 120°x120° HxV
- Response: 38Hz-17kHz
- Sensitivity: 93dB,
- Power: 250W 4Ω (150W Tx)
- Environmental: IP-X5



CONTROL 31 2-WAY HIGH OUTPUT INDOOR/OUTDOOR MONITOR SPEAKER

The Control 31 utilises high-power components, computer optimised horn, and a complex network to achieve smooth, powerful high-fidelity performance, extended bandwidth, and well-controlled defined coverage from a compact loudspeaker. Available in Black or White.

- Dispersion: 110°x110° HxV
- Response: 33Hz-19kHz
- Sensitivity: 92dB,
- Power: 200W 8Ω (150W Tx)
- Environmental: IP-55



CONTROL SB2 DUAL COIL 250MM (10in) COMPACT SUBWOOFER

The Control SB-2 functions as the subwoofer section of left/right music systems, preserving the stereo separation. The dual coil 10in transducer has been optimised to compliment four Control 23 speakers. Available in Black.

- Response: 38Hz-160Hz
- Sensitivity: 97dB
- Power: 170W 8Ω (x2)



CONTROL SB2210 DUAL 250MM COMPACT SUBWOOFER

The Control SB2210 provides low frequency reinforcement for a wide variety of sound system applications. Its compact size, high output and outdoor capable design makes it one of the most versatile subwoofers in the installation market. Available in Black.

- Response: 42Hz-200Hz
- Sensitivity: 95dB
- Power: 400W 8Ω
- Environmental: IP-45



ACCESSORIES

MTC-PC2: The MTC-PC2 Panel Cover provides sealed entrance protection for input terminals and strain relief for incoming speaker wire. MTC-xxSSG and MTC-xxWMG: SSG stainless steel retrofit grilles for Control 23, 25, and 28. WMG WeatherMax™ grilles add a foam and tight-weave backing to break up driving rain.

MTC-xxH* Horizontal Array Brackets: Allows horizontal arraying of two Control 23, 25 or 28 speakers. MTC-H brackets can be interconnected to form a suspended ring for mounting 6 or 3 speakers in a 360° cluster module.

MTC-xxV* Vertical Array Brackets: Allows vertical end-to-end mounting of up to three Control 23, 25, or 28 speakers.

MTC-xxCM* Ceiling Brackets: The curved arm allows installation of Control 23, 25, 28, 29AV or 30 speakers down from a ceiling.

MTC-30MK-WH: Marine grille kit for Control 30 (white only).

SB-2 Installation Brackets: The MTC-SB2W wall/corner bracket allows mounting of the subwoofer onto a wall surface or into a corner.

The MTC-SB2C ceiling bracket enables suspension of the SB-2 from above, projecting downward into the listening area.

PMB-BK and PMB-WH: Control CRV pole-mount bracket for 4-speaker 360° hanging pendant cluster.

Various adaptors for installing via threaded pipe or rod available from third party.

* These models are available in different sizes. Specify speaker model when ordering.

CSS Commercial Series. CEILING AND SURFACE-MOUNT SPEAKERS



CSS-1S/T 135mm (5.25IN) COMPACT TWO-WAY SPEAKER

The CSS-1S/T is a versatile, compact two-way loudspeaker designed for use on 100V or 70V distributed speaker lines or in 8 ohm direct mode. Aimable wall-mount bracket is included.

- Available in Black.
- Dispersion: 120°x 120° HxV
- Response: 85Hz-18kHz
- Sensitivity: 86dB, D
- Power: 60W 8Ω (10W Tx)

Control® 50 Series. SURFACE-MOUNT SUBWOOFER SATELLITE SYSTEM

The Control 50 Series subwoofer-satellite loudspeaker system provides high fidelity sound in any location where full-range high fidelity foreground/background music is required from a surface-mount system.

The Control 50S/T subwoofer can be utilised with either two of four Control 52 satellite speakers. The Control 50 system is mono. Both the Control 50S/T and Control 52 can be intermixed in systems along with the Control 40 Series in-ceiling models – Control 40CS/T subwoofer and Control 42 satellite speaker – to match the form factor requirements of a wide variety of applications.



CONTROL 52 60mm (2.5IN) SURFACE-MOUNT SATELLITE LOUDSPEAKER

The Control 52 satellite loudspeaker produces superb high fidelity sound via a low distortion 2.5in driver. The included wall bracket allows each speaker to be angled up to 45 degrees off-axis. Available in Black and White.

- Dispersion: 150° Conical
- Response: 140Hz-20kHz
- Sensitivity: 82dB
- Power: 15W 16Ω



CSS Commercial Series. PAGING HORNS



CSS-H15/H30 15W/30W PAGING HORNS

The CSS-H15 and H30 paging horns provide excellent voice range clarity. The wide coverage pattern allow the horns to cover larger audience areas, and they are designed for demanding environmental conditions. Available in Grey.

CSS-H15

- Dispersion: 70°x 90° HxV
- Response: 400Hz-7.5kHz
- Sensitivity: 105dB
- Power: 15W 8Ω (15W Tx)
- Environmental: IP-65

CSS-H30

- Dispersion: 50°x 70° HxV
- Response: 380Hz-6kHz
- Sensitivity: 108dB
- Power: 30W 8Ω (30W Tx)
- Environmental: IP-65



CONTROL 50S/T 200mm (8IN) SURFACE-MOUNT SUBWOOFER SYSTEM

The Control 50S/T subwoofer contains a high-power, long excursion, 8in driver which provides extended low frequency response. The Control 50S/T installs quickly with its included two-piece easy-mount wall-bracket. Available in Black and White.

- Response: 32Hz-200Hz
- Sensitivity: 89dB
- Power: 100W 8Ω (80W Tx)



CONTROL C50PACK PACKAGED SURFACE-MOUNT SUBWOOFER-SATELLITE LOUDSPEAKER SYSTEM

The Control 50Pack includes 4x Control 52 satellite speakers and 1x Control 50 subwoofer. Available in Black and White.

- Versatile four satellite speaker system
- Wall mount brackets included
- Response: 32Hz-20kHz



CONTROL 50ST



Control Pro Series. COMPACT INSTALLATION MONITORS

The JBL Control Series speakers offer well balanced sound and exceptional power handling, making these speakers ideal for any installation requiring professional control monitor performance from a compact source.

CONTROL 1 PRO 100mm (5.25IN) TWO-WAY PROFESSIONAL COMPACT LOUDSPEAKER SYSTEM

The Control 1 Pro is a high-performance compact loudspeaker system incorporating monitor-grade, magnetically shielded transducers, a professional crossover network and full-range SonicGuard overload protection. Available in Black.

- Dispersion: 100°x 100° HxV
- Response: 80Hz-20kHz
- Sensitivity: 87dB, D
- Power: 150W 4Ω



CONTROL 2P 100mm (5.25IN) COMPACT POWERED TWO-WAY LOUDSPEAKER SYSTEM

The Control 2P compact powered reference monitor system combines JBL's legendary loudspeaker design with powerful amplification to deliver rich, accurate performance for demanding audio applications. Available in Black.

- Dispersion: 100°x 100° HxV
- Response: 80Hz-20kHz
- Connector: XLR, 1/4in TRS & RCA
- Power Amp: 35W x2



CONTROL 5 125mm (6.5IN) COMPACT PASSIVE TWO-WAY LOUDSPEAKER SYSTEM

The Control 5 is a high-performance, wide range control monitor suitable for use as the primary sound source in a variety of applications. All transducers are magnetically shielded for use in close proximity to video monitors. Available in Black.

- Response: 55Hz-20kHz
- Sensitivity: 89dB, D
- Power: 85W 4Ω



Control CRV Series. ARCHITECTURAL SPEAKERS

The Control CRV brings high design and versatility to commercial applications such as restaurants, retail stores, lounges, theme bars, music cafes, hotels, boardrooms, boutiques, museums, leisure venues, outdoors, upscale lobbies, and other foreground and background music and paging applications that require a fashionable look with superb sound quality.

JBL Control CRV speakers are exceedingly versatile, with multiple installation possibilities. The JBL Control CRV speaker can be wall-mounted aimed straight out from the wall, angled down at a 45° aiming axis, mounted spanning the junction of a wall and ceiling, or spanning the junction of a wall and another wall. At a junction, the unique curved shape of the speaker couples well with both boundary surfaces, forming a dual ground plane configuration which increases the acoustic length of the speaker, providing additional spaciousness to the sound character and increased bass output. In addition, two or three Control CRV speakers can be joined together to create loudspeaker solutions for a wide variety of coverage, appearance and mounting requirements. Using the optional PMB pole-mount bracket, four speakers can be joined together and suspended by a ceiling fan pole to form a cluster module with 360° horizontal coverage.

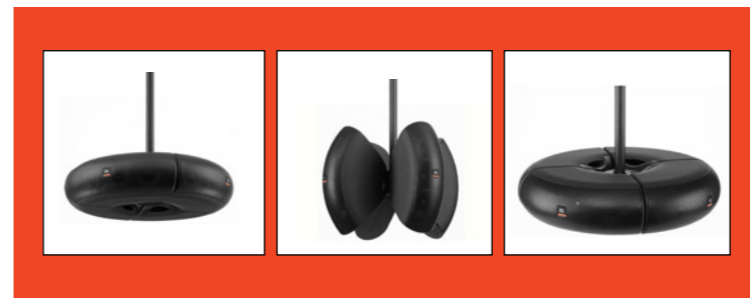

CONTROL CRV CONTEMPORARY CURVED DESIGN LOUDSPEAKER

Control CRV are outdoor capable to IP-34 (per IEC 529), utilising stainless steel screws, professional outdoor-rated screw-down terminals, and screened ports to prevent ingress of pests. Available in Black or White.

- Dispersion: 80°x 105° HxV
- Response: 80Hz-20kHz
- Sensitivity: 89dB, D, WG
- Power: 60W 4Ω (30W Tx)
- Environmental: IP-34



Control HST Series.

ARCHITECTURAL SPEAKERS

The Control HST utilizes JBL's patent-pending Hemispherical Soundfield Technology™ to achieve extremely wide coverage of the listening space along with eliminating the primary wall reflection that tends to cause inconsistent sound when speakers are attached to a wall. The wide hemispherical soundfield covers from wall to wall, allowing a single speaker to provide high-fidelity full-range sound to a large listening area. This can reduce the number of speakers needed for covering a space, lowering the overall cost for a sound system.



CONTROL HST

WIDE-COVERAGE SPEAKER WITH 5-1/4IN LF, DUAL TWEETERS AND HST TECHNOLOGY™ LOUDSPEAKER

Control HST is ideal for a wide variety of applications, including retail stores, restaurants, corridors, educational facilities, hospitality, music cafes, leisure venues, upscale lobbies, and other background/foreground music and paging applications. The IP-54 outdoor capability also makes it suitable for applications where an outdoor capable speaker is required. The system is capable of handling 100 Watts, and is equipped with a 60W/70V/100V multi-tap transformer. Available in Black or White.

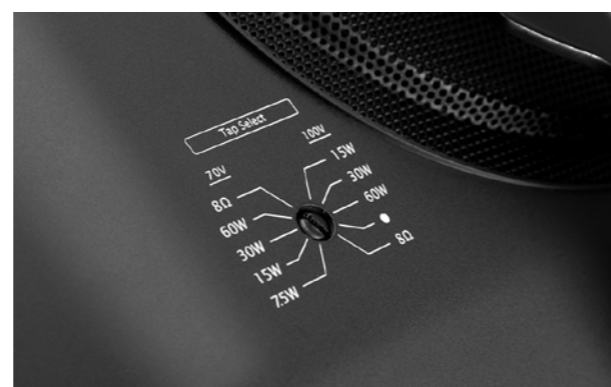

- Dispersion: 160°x 150° HxV
- Response: 50Hz-20kHz
- Sensitivity: 88dB, D, WG
- Power: 75W 8Ω (60W Tx)
- Environmental: IP-54



PENDANT SPEAKERS



Vans Store Gangnam, South Korea

Control 60 Series.

HIGH PERFORMANCE PENDANT LOUDSPEAKERS

The Control 60 Series bring renowned JBL sound and outstanding coverage to rooms and venues with open architecture or high-ceilings, while providing superior voice and musical clarity for rooms with difficult acoustics. Easy to install stainless steel hanging hardware is included, featuring redundant suspension cables and UL listed adjustable height hangers. The Control 60 Series pendant speakers are outdoor capable to IP44 (per IEC 529) and pair perfectly with the Control 40 Series ceiling speakers as they share the same sound signature and sonic characteristics.

CONTROL 62P

50MM (2.5IN) ULTRA-COMPACT SATELLITE PENDANT SPEAKER

The Control 62P is great for speech and mid-high music applications (external high-pass required) in visually sensitive applications. For full-range applications, up to 4 pieces can be driven from a Control 50S/T or 40CS/T subwoofer. Available in Black or White.

- Dispersion: 140° Conical
- Response: 150Hz-20kHz
- Sensitivity: 84dB
- Power: 15W 16Ω
- Environmental: IP-44



CONTROL 64P/T

100MM (4IN) COMPACT FULL RANGE PENDANT SPEAKER WITH RBI™

The Control 64P/T is a compact full-range, pendant-type loudspeaker that provides superb sound reproduction for rooms with open architecture ceilings and other locations where a pendant form factor is desired. Available in Black or White.

- Dispersion: 120° Conical
- Response: 55Hz-20kHz
- Sensitivity: 86dB, D, WG
- Power: 75W 8Ω (60W Tx)
- Environmental: IP-44



CONTROL 65P/T

133MM (5.25IN) COMPACT FULL RANGE PENDANT SPEAKER WITH RBI™

The Control 65P/T incorporates JBL's exclusive RBI Radiation Boundary Integration technology to provide very consistent, wide coverage throughout the listening space. 120° constant directivity broadband pattern control. Available in Black or White.

- Dispersion: 120° Conical
- Response: 55Hz-20kHz
- Sensitivity: 86dB, D, WG
- Power: 75W 8Ω (60W Tx)
- Environmental: IP-44



Control 60 Series.



CONTROL 67P/T

158mm (6.5IN) EXTENDED RANGE PENDANT SPEAKER WITH RBI™

The Control 67P/T incorporates a larger enclosure and high power 6.5in transducer for extended bass output capability. 120° constant directivity broadband pattern control. Available in Black or White.

- Dispersion: 120° Conical
- Response: 58Hz-18kHz
- Sensitivity: 90dB, D, WG
- Power: 75W 8Ω (60W Tx)
- Environmental: IP-44



CONTROL 67HC/T

158mm (6.5IN) HIGH CEILING PENDANT SPEAKER WITH RBI™

The Control 67HC/T has well controlled narrow coverage, ideal for improved voice intelligibility and musical clarity in high-ceiling venues or in rooms with difficult acoustics. Narrow 75° constant directivity broadband pattern control. Available in Black or White.

- Dispersion: 75° Conical
- Response: 75Hz-17kHz
- Sensitivity: 93dB, D, WG
- Power: 75W 8Ω (60W Tx)
- Environmental: IP-44



CONTROL 60PS/T

200mm (8IN) PENDANT SUBWOOFER WITH CROSSOVER

The Control 60 PS/T provides bass and extension, high impact and good transient response for high-fidelity sound systems. Available in Black or White.

- Response: 42Hz-350Hz
- Sensitivity: 89dB
- Power: 150W 8Ω (110W Tx)
- Environmental: IP-44



ACCESSORIES

MTC-PC60: Terminal Cover for C65P/T, C67P/T, C67HC/T & C60PS/T
MTC-PC62: Terminal Cover for C62P

IN-WALL SPEAKERS

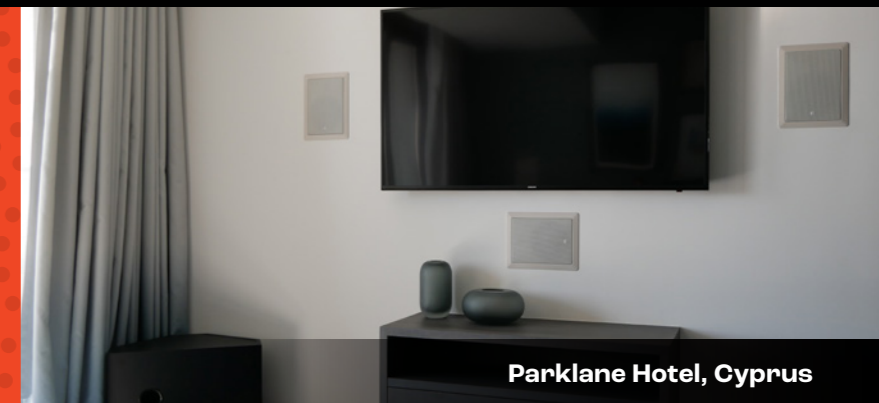

Control® Contractor 100 Series.

EASY TO INSTALL WALL SPEAKERS

The Control 100 Speakers are premium in-wall speakers designed for applications where top performance from a loudspeaker with minimal visual impact is required, such as common theatre spaces. The Control 100 Series speakers are voiced similarly to other JBL control Contractor models, allowing mixing with surface-mount and in-ceiling speakers within a single listening space. The premium sound quality makes these loudspeakers ideal for critical listening environments, yet they are high power and rugged enough to handle venues requiring high-SPL heavy duty-cycle music.

CONTROL 126W/WT

PREMIUM IN-WALL LOUDSPEAKER

The Control 126W is a premium in-wall speaker within the JBL Professional Control® Contractor line designed for applications such as foreground music, boardrooms, reception areas, airports, convention centres, cruise ships, retail outlets, restaurants, museums, surround locations, or any critical listening application where top performance from a loudspeaker with minimal visual impact is required. Available in White.

- Response: 38Hz-20kHz
- Sensitivity: 88dB, D
- Power: 50W 8Ω W / 30W Tx WT



CONTROL 128W/WT

PREMIUM IN-WALL LOUDSPEAKER

The Control 128W is a premium in-wall speaker within the JBL Professional Control® Contractor line designed for applications such as foreground music, boardrooms, reception areas, airports, convention centres, cruise ships, retail outlets, restaurants, museums, surround locations, or any critical listening application where top performance from a loudspeaker with minimal visual impact is required. Available in White.

- Response: 30Hz-20kHz
- Sensitivity: 90dB, D
- Power: 60W 8Ω W / 50W Tx WT



LANDSCAPE SPEAKERS



Parklane Hotel, Cyprus

GSF Series. GARDEN GROUND-STAKE FULL-RANGE SPEAKERS

Weather-resistant JBL GSF garden ground-stake full-range speakers provide superior fidelity and wide coverage in a range of outdoor commercial applications. Available in hunter green and tan finishes, these speakers are the perfect sound solution for diverse outdoor applications including shopping malls, theme parks, sports venues, hospitality venues, and any application calling for a stylish, robust, great-sounding landscape speaker system.

(includes L-bracket and ground stake)



Control 80 Series. MUSHROOM TYPE OUTDOOR LANDSCAPE LOUDSPEAKERS

The Control 80 Series mushroom-type landscape speakers feature high fidelity performance for outdoor in-ground or on-ground use in applications such as hotels, restaurants, and shopping complexes. A wide frequency response and 360° of horizontal coverage ensure coverage of outdoor spaces with top-quality music and/or intelligible paging. The wiring entrance is via an included water-tight gland nut fitting which can be located in a number of positions on the speaker (installed in the field). A double-chamber seal helps to further protect connections and electrical components for long-term reliability. Colour infused throughout the enclosure case minimises the visual impact of the nicks and scratches that can happen with outdoor speakers. The Control 80 Series are IP-55 rated as per IEC529 (protected against jets of water) and exceeds MilSpec 810 for humidity, salt spray, temperature and UV.



CONTROL 85M TWO-WAY 135mm (5.25IN) COAXIAL MUSHROOM LANDSCAPE SPEAKER

- Dispersion: 360°x 160° HxV
- Response: 55Hz-18kHz
- Sensitivity: 86dB, D, WG
- Power: 45W 8Ω (30W Tx)
- Environmental: IP-56
- Available in Green



CONTROL 89MS LONG-THROW 200mm (8IN) MUSHROOM LANDSCAPE SUBWOOFER

- Dispersion: 360°x160° HxV
- Response: 40Hz-150Hz
- Sensitivity: 87dB
- Power: 150W
- Environmental: IP56
- Available in Green



GSF3 76mm (3IN) GROUND-STAKE LANDSCAPE SPEAKER

- Dispersion: 90° conical
- Response: 74Hz-20kHz
- Sensitivity: 84dB
- Power: 30W
- Environmental: IP66
- Available in Green and Tan



GSF6 152mm (6IN) GROUND-STAKE LANDSCAPE SPEAKER

- Dispersion: 70° conical
- Response: 65Hz-20kHz
- Sensitivity: 87dB
- Power: 50W
- Environmental: IP66
- Available in Green and Tan



CONTROL 88M TWO-WAY 200mm (8IN) COAXIAL MUSHROOM LANDSCAPE SPEAKER

- Dispersion: 360°x 160° HxV
- Response: 47Hz-16kHz
- Sensitivity: 87dB, D, WG
- Power: 100W 8Ω (60W Tx)
- Environmental: IP-56
- Available in Green.

GSB Series. GARDEN IN-GROUND SUBWOOFERS

JBL GSB in-ground landscape subwoofers augment the low-frequency performance of JBL GSF full-range landscape speakers to provide rich, full-range sound in lawn and garden areas of hospitality, corporate and retail spaces. Add GSB subwoofers to landscape areas of hotels, shopping complexes, restaurants, public spaces, theme parks or any application that demands legendary JBL sound with deep, rich, powerful bass.



SOUNDBARS



JBL Pro Soundbar. COMMERCIAL GRADE ACTIVE SOUNDBAR

The JBL Pro SoundBar PSB-1 is a cost-effective, commercial-grade active soundbar designed specifically for use in applications such as hotel guestrooms, cruise ship staterooms, meeting rooms and public spaces. With an optimised feature set targeting the unique requirements of these applications, the Pro SoundBar reduces the cost and complexity found in consumer-grade soundbars while providing excellent sound quality, security, and reliability.

The all-in-one design of the Pro SoundBar provides full-range sound without the need for a separate subwoofer, providing excellent quality audio while minimising sound transfer to neighboring rooms. For further volume management, the Pro SoundBar offers a 4-position volume limiting switch to control the maximum volume output of the soundbar. The Pro SoundBar supports both fixed and variable source volume for maximum TV compatibility. Controls for the volume switch and source volume selection can be covered by a lockout plate to prevent tampering by anyone other than the support staff.



GSB8 203mm (8IN) IN-GROUND LANDSCAPE SUBWOOFER

- Dispersion: 360°x160° HxV
- Response: 35Hz-130Hz
- Sensitivity: 84dB
- Power: 250W
- Environmental: IP66
- Available in Green and Tan



GSB12 305mm (12IN) IN-GROUND LANDSCAPE SUBWOOFER

- Dispersion: 360°x160° HxV
- Response: 30Hz-120Hz
- Sensitivity: 85.5dB
- Power: 450W
- Environmental: IP66
- Available in Green and Tan

PSB-1 2.0 CHANNEL COMMERCIAL GRADE SOUNDBAR

- Response: 42Hz-20kHz
- Connector: RCA x2
- Power Amp: 20W x2
- Available in Black

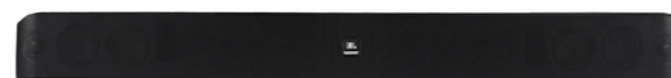

Clarity at Any Level

Better clarity at low levels allows users to hear without increasing volume to intrusive levels.

Front-Facing Speakers

Front-facing speakers offer improved clarity over internal television speakers. TV speakers are typically rear or downward facing, diminishing the quality and volume and increasing sound transference.

Premium Materials

No cloth is used on the speaker grill, making the product easier to clean and maintain and less prone to damage.

Flexible and Easy to Use

The JBL Pro SoundBar is compatible with both fixed volume and variable volume control schemes. Whether the volume is controlled directly at the soundbar or upstream at the TV, the Pro SoundBar is able to support these scenarios, with a single remote controlling the entire system.

This is made possible by the Pro SoundBar's IR Learning feature. In fixed volume scenarios, where the volume is controlled at the soundbar, the Pro SoundBar is able to "learn" the IR pulse of volume up and volume down controls, meaning any remote can be used—programmable or not. This allows guests to use a television remote to adjust the entire system without the need to use a smart remote. No matter the system requirements, the JBL Pro SoundBar offers users a simplified experience.

COLUMN LOUDSPEAKERS

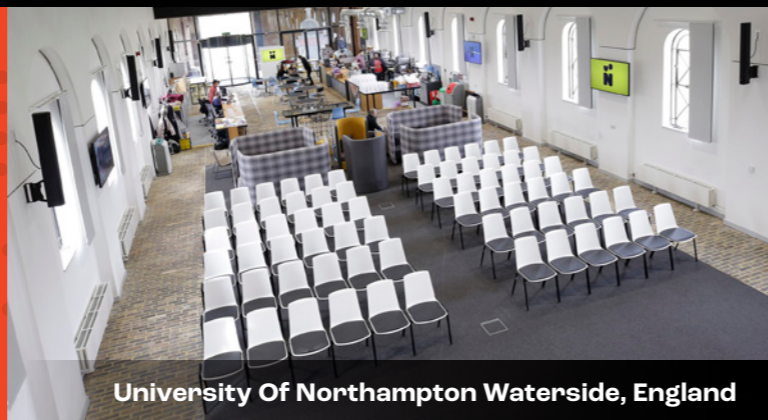

University Of Northampton Waterside, England



Seongsan Methodist Church, Republic Of Korea

JBL CBT Series. LINE ARRAY COLUMN LOUDSPEAKERS

The JBL CBT Series line array columns with Constant Beamwidth Technology break new ground in performance, versatility, and affordability. Designed for venues that would typically use larger point-and-shoot speakers or powered columns, the CBT models incorporate patented technical advancements that allow them to vastly outperform competitive systems, with a level of user-friendliness that virtually eliminates the challenges of delivering great sound. With a slim compact design in fibreglass reinforced ABS enclosures, the CBT Series fits well into virtually any decor. When installed with optional MTC-PC2 panel cover, the CBT series is IP-55 rated (per IEC529).

CBT 50LA-1 50CM TALL LINE ARRAY COLUMN WITH 8X 50mm DRIVERS

The CBT 50LA-1 is the most compact of the models. At 150 watts, it holds its own against larger competitive columns. Response to 80 Hz works well for speech or music. Voicing can be set for music (flat) or speech via a switch. Available in Black or White.

- Dispersion: 150°x 20° HxV
- Response: 80Hz-20kHz
- Sensitivity: 89dB-93dB (Variable modes)
- Power: 100W 8Ω (60W Tx)
- Environmental: IP-55



Also available: Control 50LA-LS – EN54-24 Certified for life safety applications

CBT 100LA-1 100CM TALL LINE ARRAY COLUMN WITH 16X 50mm DRIVERS

The CBT 100LA-1 contains 16x 2in drivers in a slim, compact cabinet, providing excellent pattern control. Vertical coverage is adjustable via a switch and voicing is switchable between music (flat) or speech setting, making this model a great choice for a wide variety of environments. Available in Black or White.

- Dispersion: 150°x 15°/40° HxV
- Response: 80Hz-20kHz
- Sensitivity: 93dB-96dB (Variable modes)
- Power: 200W 8Ω (120W Tx)
- Environmental: IP-55



Also available: Control 100LA-LS – EN54-24 Certified for life safety applications

CBT 200LA-1 200CM TALL LINE ARRAY COLUMN WITH 32X 50mm DRIVERS

With a height of 200cm (6.6 ft), CBT 200LA-1 is the tallest model, providing useful pattern control down to below 200Hz. The top and bottom speaker modules allow individual adjustment of music (flat)/ speech voicing and vertical pattern settings. Setting in Asymmetrical Progressive Gradient coverage mode (top narrow; bottom broad) sends more sound toward the far listening area versus close for more even SPL near-to-far in the listening space. Available in Black or White.

- Dispersion: 150°x 15°/30° HxV
- Response: 80Hz-20kHz
- Sensitivity: 90dB-95dB (Variable modes)
- Power: 400W 4Ω (240W Tx)
- Environmental: IP-55



CBT 70J-1 TWO-WAY LINE ARRAY COLUMN WITH ASYMMETRICAL VERTICAL COVERAGE

The CBTJ-1 is a two-way speaker with high fidelity and response down to 60Hz, 500W power handling, high sensitivity and high SPL capability. This model provides Asymmetrical Progressive Gradient coverage sending more sound toward the far area of the listening space. Available in Black or White.

- Dispersion: 150°x 25°/45° HxV
- Response: 60Hz-20kHz
- Sensitivity: 92dB-98dB (Variable modes)
- Power: 350W 8Ω
- Environmental: IP-55





CBT 70JE-1
PURPOSE DESIGNED EXTENSION FOR CTB 70J-1

The CTB 70JE-1 extension speaker is purpose-built for use with CBT 70J-1, lengthening the line array to extend the pattern control, extending the bass response, and increasing power handling SPL levels in the LF range. Available in Black or White.

- Response: 45Hz-700Hz
- Sensitivity: 90dB
- Power: 350W 8Ω
- Environmental: IP-55



CBT 1000
CONSTANT BEAMWIDTH TECHNOLOGY™
ADJUSTABLE COVERAGE LINE ARRAY COLUMN

Expanding upon our highly successful Constant Beamwidth Technology™ breakthrough, the CBT 1000 represents the next generation in pattern control consistency utilising adjustable vertical coverage and a tapered horizontal waveguide to increase the versatility of aiming the coverage of the loudspeaker to more accurately map to the room geometry in a wide variety of listening spaces. Available in Black or White.

- Dispersion Horizontal: 160° to 100° (Asym)
- Dispersion Vertical: 16 Variable Patterns
- Response: 45Hz-20kHz
- Sensitivity: 95dB-102dB (Variable modes)
- Power: 1000W 4Ω
- Environmental: IP55

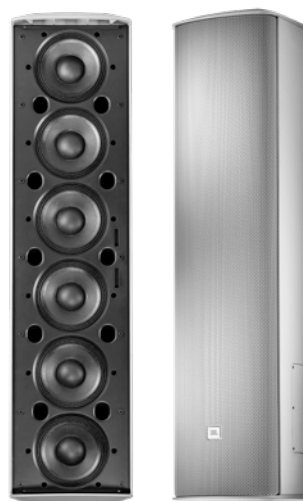

CBT 1000E
PURPOSE-DESIGNED EXTENSION FOR CBT 1000
LINE ARRAY COLUMN SPEAKER

When connected to a CBT 1000 line array column speaker, the CBT 1000E Extension provides extended bass response, extended pattern control, and increased sound output levels. Available in Black or White.

- Response: 38Hz-650Hz
- Sensitivity: 92dB
- Power: 1000W 8Ω
- Environmental: IP-55

ACCESSORIES

MTC-CBT-70T - Transformer module for CBT 70J-1 or 70J-1 + 70JE-1 array, bolts onto back, 70V/1 00V taps at 120W, 60W, 30W (plus 15W for 70V), gland nuts for water tight seal.

MTC-CBT-SMB1 - Stand Mount Bracket fits all models for portable applications. Note: For stability, CST 70J+E array system and CST 200LA-1 requires larger, heavier-duty stand than JBL SS2-BK.

MTC-CBT-FM1 - Low-profile, close-to-wall mounting bracket for use with CBT 50LA-1, CBT50LA-LS, and CST 1 00LA-1 and CBT 1 00LALS.

MTC-CBT-FM2 - Low-profile, close-to-wall mounting bracket for use with CBT 70J-1 and CST 70J-1/70JE-1 array.

CBT Calculator Software - For designing CBT speakers into projects. Download from jblpro.com website.



JBL COL Series.
SLIM COLUMN LOUDSPEAKERS

The JBL COL Slim Column Loudspeaker product family includes the COL600 (24-Inch 600 mm) and COL800 (32-Inch 800 mm). Both provide wide horizontal and narrow vertical coverage, with a built-in 10° down-tilt to the aim, providing optimum coverage for most listening areas while allowing the speaker to be installed flat to the wall. The slim, compact design—winner of international design awards for industrial design excellence—complements virtually any architectural décor. A combination of stylish design and outstanding performance features makes these loudspeakers ideal for a wide variety of applications, such as conference/meeting rooms, lecture halls, retail stores, concourses, transit spaces, fill applications, audio for video, and other applications where slim, compact design and high performance is desired.



COL600
600mm (24in) SLIM COLUMN LOUDSPEAKER

Two 5-inch x 2.25 inch racetrack woofers provide maximum radiating area in a column form factor. The tweeter is located at top of array for less obstructed coverage of the listening space and is aimed at a down angle, allowing down-tilted coverage aim, even with the cabinet flat to the wall. The shallow cabinet depth of 3.7 inches (93 mm) qualifies for ADA (Americans with Disabilities Act) projects when installed with the back of the cabinet flush to the wall. Available in Black or White.

- (2) 5 x 2.25 inch racetrack woofers and (1) 1 inch tweeter
- 70 Hz – 20 kHz frequency range
- Wide 160° horizontal and focused 110° vertical coverage
- 111 dB peak SPL (105 dB continuous), 2 hrs



COL800
800mm (32in) SLIM COLUMN LOUDSPEAKER

Four 5-inch x 2.25-inch racetrack woofers provide maximum radiating area in a column form factor. Dual tweeters are located at top of the array for less obstructed coverage of the listening space, and they are aimed at a 10° down angle, allowing down-tilted coverage aim, even with the cabinet flat to the wall. The shallow cabinet depth of 3.7 inches (93 mm) qualifies for ADA (Americans with Disabilities Act) projects when installed with the back of the cabinet flush to the wall. Available in Black or White.

- (4) 5-inch x 2.25-inch racetrack woofers and (2) 0.8-inch tweeters
- 85 Hz – 20 kHz frequency range
- Wide 160° horizontal and focused 60° vertical coverage
- 116 dB peak SPL (110 dB continuous), 2 hrs

BEAM FORMING COLUMNS



The School Of Nichiren's Daijozan Houonji Temple, Japan

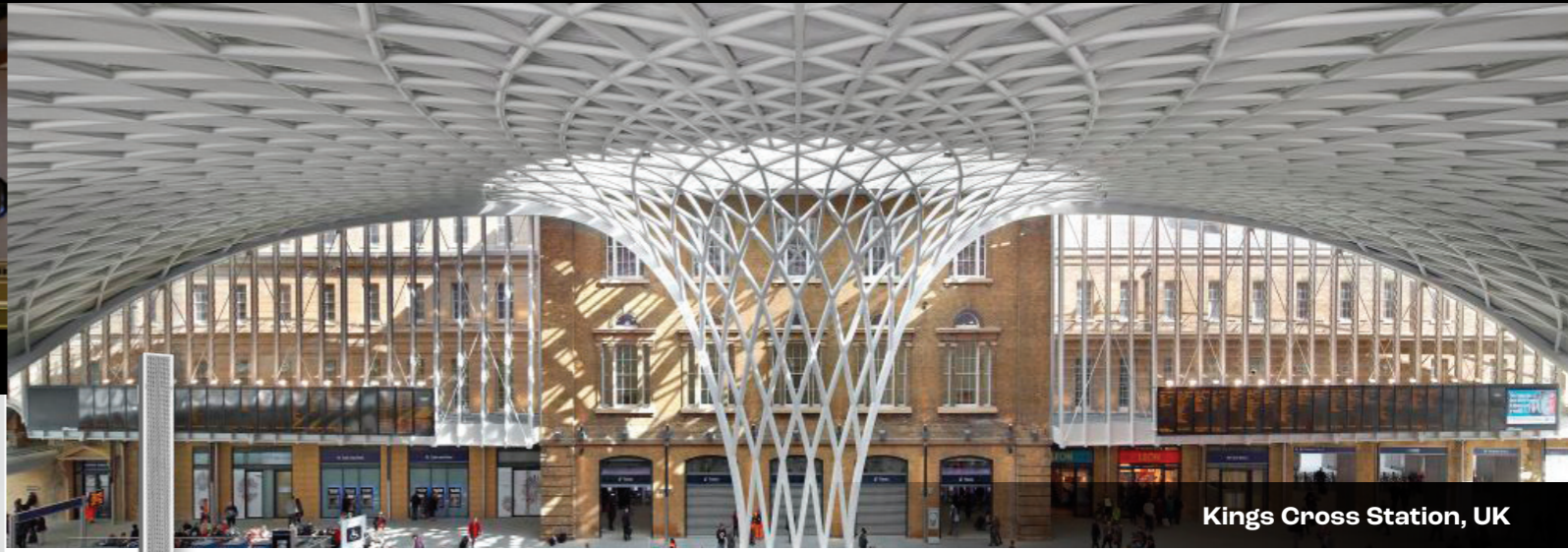

Kings Cross Station, UK

JBL Intellivox Series.

**BEAM FORMING, SELF POWERED
LOUDSPEAKER ARRAYS**

The JBL Intellivox Series has revolutionised directivity control. If you need to deliver a clear & intelligible message and/or musical clarity in a large reverberant space, then Intellivox is the solution. Thanks to its small cross section and neutral visual design, Intellivox can blend into any environment, allowing sound system designers, architects and acoustic engineers to work together to deliver systems that not only look great but sound great too. Intellivox's pioneering of Beam Steering wasn't the end of the journey, but just the start. Ground-breaking Beam Shaping technology delivers a level of control that is quite simply unmatched. Its superior coverage capabilities once again set a new bench mark within its class. JBL has been constantly improving their DDC (Digital Directivity Control for beam steering) and DDS (Digital Directivity Synthesis for complex beam shaping) technologies, to ensure that the systems continually outpace the competition and are easy to set up and operate.



WHY CHOOSE INTELLIVOX? A GREAT SOUNDING SYSTEM

Quality sound reproduction – delivering the ultimate intelligibility:

- Highly intelligible speech reinforcement
- Natural sound reproduction
- High direct-to-reverberant ratio
- Free from distortion
- Even SPL coverage (The sound level from a properly set up Intellivox unit will be the same, whether the listener is at a distance or close up)

Digital directivity technologies ensure a high ratio of direct sound to reverberant sound which is critical to the intelligibility of any sound system.

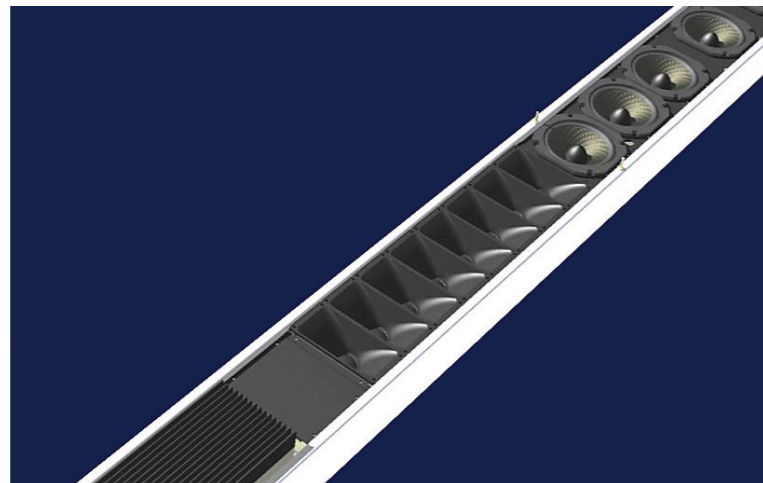

A GREAT LOOKING SYSTEM

Architectural Integration – for systems that look great and sound great

- No need for mechanical aiming
- Units can be mounted vertically
- Units can be recessed into surfaces
- Colour matching service available
- Units have a slim and unobtrusive design
- Can be integrated into buildings of all ages and styles.

AN EASY TO INSTALL AND MAINTAIN SYSTEM

- Fewer installation/maintenance points than conventional distributed systems
- Units can be configured from a single control point via an RS-485 network
- A wide range of mounting and cable entry options
- All parts & connections are accessible from the front as well as the rear of the unit making it possible to service the unit in situ
- Most units can be ordered with the electronics module at the top or bottom of the enclosure, allowing additional architectural flexibility.



JFK Terminal 4, USA



Cologne Dome, Germany



Covington Cathedral, USA

A SAFE AND RELIABLE SYSTEM

Emergency sound systems - Intellivox products are designed for use in emergency sound systems:

- Designed to provide reliable operation
- In some cases, Intellivox products are the only way of achieving the required levels of speech intelligibility in a large reverberant space
- All elements of Intellivox products are constantly monitored by the on board RISC processor
- Faults can be reported via the built in failure relay or via the network
- WinControl servers can be supplied to provide fault logging and to interface to external controllers.

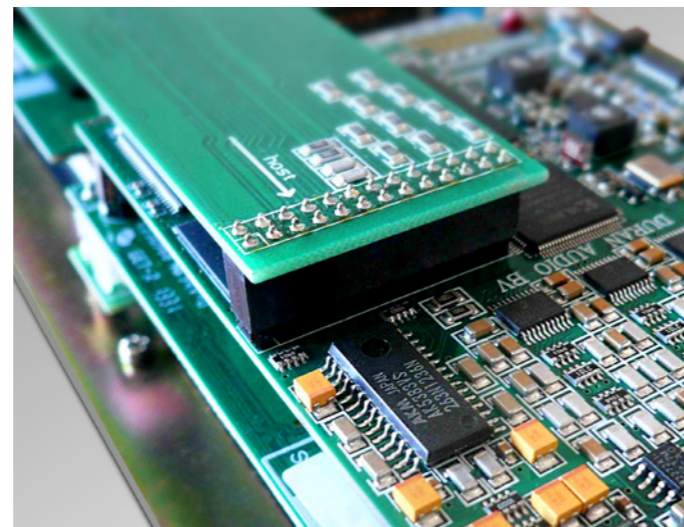
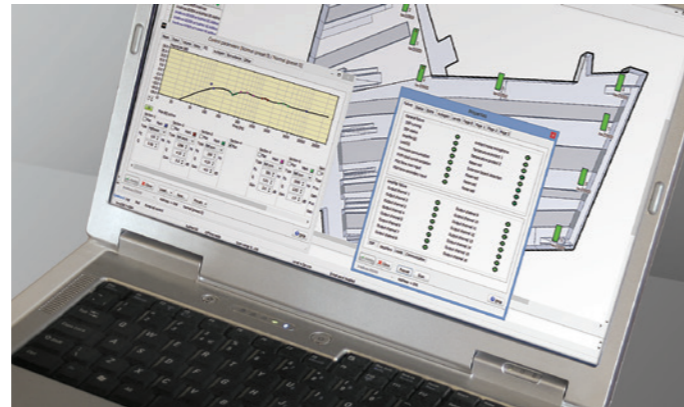

Integrated electronics module which combines powerful Digital Signal Processing with multi-channel class D Amplifiers

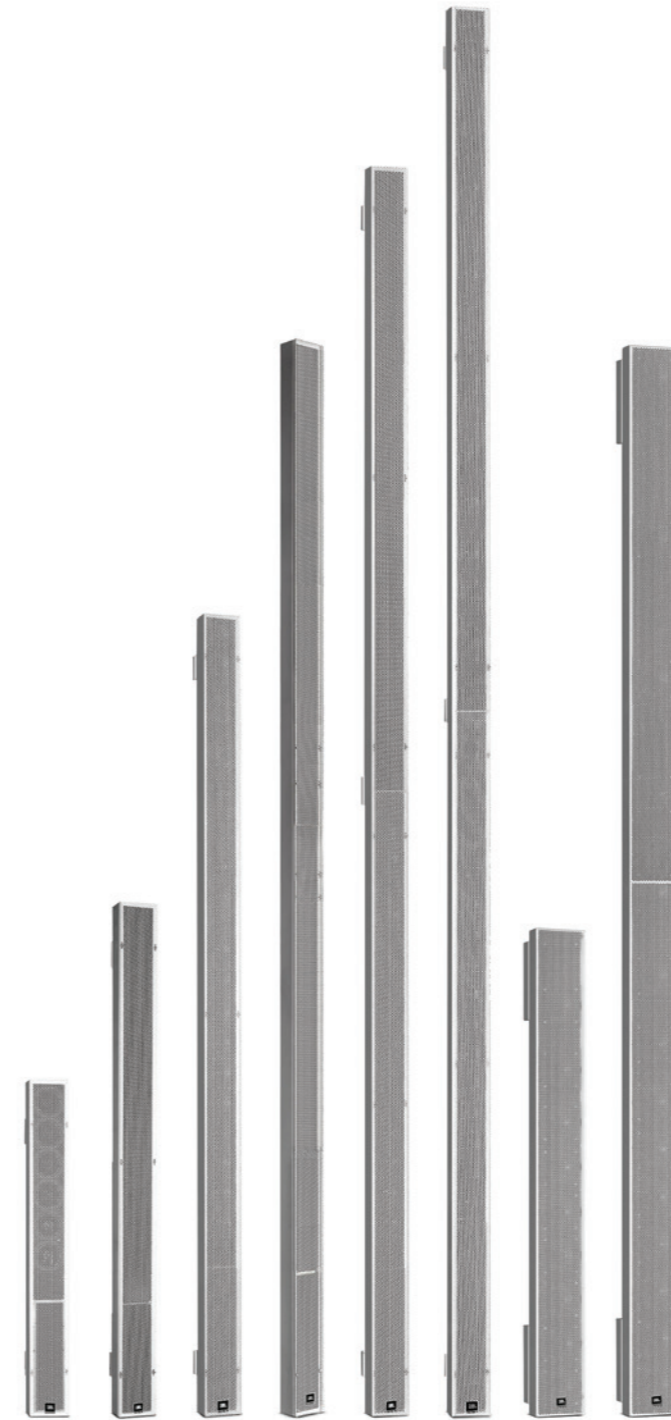

DDA (DIGITAL DIRECTIVITY ANALYSIS)

DDA is a powerful yet intuitive Windows application for accurately predicting the electro-acoustic performance of loudspeaker systems in (semi) open or closed spaces. It includes 3D room acoustic modelling, direct sound simulation as well as statistical prediction of various acoustic parameters.

DDA supports all JBL point source loudspeakers with CLF data and all JBL Intellivox products. Intellivox makes use of JBL's advanced beam shaping (DDS) technologies. From DDA the radiation pattern of JBL Intellivox loudspeaker arrays can be controlled precisely and tailored to the shape and the acoustics of the space. In addition, DDA offers various design tools which reduce design time and help the sound designer to optimise the system performance. For installation and commissioning purposes DDA also generates FIR output filters which can be uploaded to supported DDS-controlled loudspeaker arrays using the JBL WinControl software.

THE JBL PROFESSIONAL INTELLIVOX FAMILY

DS/DSX500
DS/DSX430
DS/DSX380
HP-DS370

DS/DSX280
DS/DSX180
HP-DS170
DS115

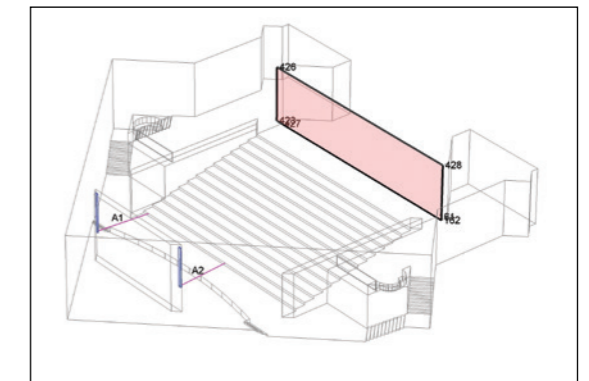

POINT-SOURCE SPEAKERS



AE APPLICATION ENGINEERED™ SPEAKERS. ORIGINAL SERIES LOUDSPEAKERS

Imagine if your every need was not only met, but anticipated. The Application Engineered Series does exactly that. The AE Series is a complete line of permanent installation loudspeakers, containing the performance and features that meet the needs of contractors and consultants alike. Incorporating the latest loudspeaker technology, a wide selection of models, high performance features, reliability, and a systems approach. AE Series has a loudspeaker for just about any challenge you might encounter. Optional Weather Protection treatment is available.



AM7212 HIGH-POWER 300mm (12in) TWO-WAY

The AM7212 loudspeaker system is comprised of one 300mm (12in) Differential Drive 2262H woofer and a 2432H high frequency compression driver. The large format PT waveguide provides excellent coverage and is rotatable for use in either the vertical or horizontal orientation. Available in Black or White and WRC/WRX finishes for extreme weather protection.

Available in five models:
 AM7212/64: 60° x 40° AM7212/95: 90° x 50°
 AM7212/00: 100° x 100°
 AM7212/66: 60° x 60° AM7212/26: 120° x 60°

- Response: 36Hz-20kHz
- Sensitivity: 95dB
- Power: 600W 8Ω (Bi-Amp Switchable)
- Environmental: IP-X3, Optional IP-55 or IP-56
- Suspension: M10 x15



AM7215 HIGH-POWER 380mm (15in) TWO-WAY

The AM7215 loudspeaker system is comprised of one 380mm (15in) Differential Drive 2262H woofer and a 2432H high frequency compression driver. The large format PT waveguide provides excellent coverage and is rotatable for use in either the vertical or horizontal orientation. Available in Black or White and WRC/WRX finishes for extreme weather protection.

Available in four models:
 AM7215/64: 60° x 40° AM7215/95: 90° x 50°
 AM7215/66: 60° x 60° AM7215/26: 120° x 60°

- Response: 34Hz-20kHz
- Sensitivity: 96dB
- Power: 600W 8Ω (Bi-Amp Switchable)
- Environmental: IP-X3, Optional IP-55 or IP-56
- Suspension: M10 x15



AM5212 MEDIUM-POWER 300mm (12in) TWO-WAY

The AM5212 loudspeaker system is comprised of one 300mm (12in) Differential Drive 262H-1 woofer and a 2408H-1 high frequency compression driver. The large format PT waveguide provides excellent coverage and is rotatable for use in either the vertical or horizontal orientation. Available in Black or White and WRC/WRX finishes for extreme weather protection.

Available in five models:
 AM5212/64: 60° x 40° AM5212/95: 90° x 50°
 AM5212/66: 60° x 60° AM5212/00: 100° x 100°
 AM5212/26: 120° x 60°

- Response: 37Hz-20kHz
- Sensitivity: 96dB
- Power: 300W 8Ω (Bi-Amp Switchable)
- Environmental: IP-X3, Optional IP-55 or IP-56
- Suspension: M10 x15



AE SERIES POINT-SOURCE LOUDSPEAKERS

AE Series loudspeakers are ideal for a wide variety of fixed installation applications including performing arts facilities, theatrical sound design, auditoriums, houses of worship, live music clubs, dance clubs/ discotheques, sports facilities and themed entertainment venues.

The special mid-high frequency models can be used without LF reinforcement in voice-only PA and delay-fill applications. The smaller models are ideal in lecture halls and corporate learning centres as well as in delay-fill locations of larger systems.

AE Series models provide a wide variety of building blocks for system designers to achieve just the right solution for any installation.

Within the AE Series there are three power footprint levels. The high output models are found in the 7000 and 6000, medium output power level is found in the 5000 and 4000 with lower output power found in the Compact AC series and Expansion AC series.

Many AE Series speakers offer selectable crossover modes: tri-amp/bi-amp or bi-amp/ passive switchable. In addition, AE Series models incorporate sophisticated crossover designs for outstanding sound quality and consistent coverage. To minimise overlap between adjacent frequency bands, steep slopes are utilised in passive crossovers — most are 4th order (24 dB/octave).

This reduces off-axis lobing, providing consistent coverage throughout the crossover region. Conjugate networks are added in some models to fine tune the frequency response for optimum sound quality.



Differential Drive Technology

JBL's exclusive Differential Drive technology is at the core of the AM5212, AM5215, AM7212, AM7215, AM7315, AM7200 and AL7115 as well as the ASB6112, ASB6115, ASB6125, ASB7118 and ASB7128. This technology reduces weight while enhancing all critical performance parameters.

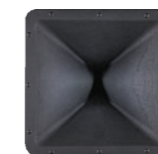

Progressive Transition Waveguides

JBL's new patent pending Progressive Transition waveguides represent the latest in horn technology. In addition to providing smooth, low distortion sound, PT waveguides deliver uniform off-axis frequency response to every point within the intended coverage area.

CMCD™ Cone Midrange Compression Drivers

Incorporated into all cone midrange models — patented CMCD technology is more than a simple displacement plug. In addition to providing increased output and lower distortion, this cone-based true compression driver design extends operational bandwidth (both up and down in frequency) to cover the entire vocal range seamlessly, allows for better waveguide pattern control, and improves phase coherency of the midrange signal for clearer, more intelligible audio quality.





Rosewood Bangkok Hotel, Thailand

AM5215
MEDIUM-POWER 380mm (15in) TWO-WAY

The AM5212 loudspeaker system is comprised of one 380mm (15in) Differential Drive 265H-1 woofer and a 2408H-1 high frequency compression driver. The large format PT waveguide provides excellent coverage and is rotatable for use in either the vertical or horizontal orientation. Available in Black, White and WRC/WRX weather resistant finishes.

- Response: 35Hz-20kHz
- Sensitivity: 98dB
- Power: 350W 8Ω (Bi-Amp Switchable)
- Environmental: IP-X3, Optional IP-55 or IP-56
- Suspension: M10 x15

Available in four models:

- AM5215/64: 60° x 40°
- AM5215/66: 60° x 60°
- AM5215/95: 90° x 50°
- AM5215/26: 120° x 60°



AM7315
HIGH-POWER 380mm (15in) THREE-WAY

The AM7315 loudspeaker system is comprised of a 380mm (15in) low frequency woofer, one 8in CMCD compression driver, and one 38mm (1.5in) exit compression driver. The multi-band PT mid-high frequency waveguide provides well controlled coverage and is rotatable for cabinet positioning in either horizontal or vertical orientation. Black DuraFlex™ finish. White available upon request.

- Response: 38Hz-20kHz
- Sensitivity: LF 97dB, MHF 108dB
- Power: LF 600W 8Ω, MHF 200W 8Ω (Tri-Amp Switchable)
- Environmental: IP-X3, Optional IP-55 or IP-56
- Suspension: M10 x13

Available in two models:

- AM7315/95: 90° x 50°
- AM7315/64: 60° x 40°



AE Application Engineered™ Subwoofers.
ORIGINAL SERIES SUBWOOFERS

AL7115
HIGH POWER 15in LOW FREQUENCY TRAPEZOIDAL LOUDSPEAKER SYSTEM

The AL7115 loudspeaker system is comprised of one 15in JBL Differential Drive 2265H woofer in a front-loaded, vented configuration. This model arrays with various AE series mid-high frequency and compact two-way models. Available in Black DuraFlex™ finish. White available on request.

- Cabinet matches AM7315 footprint
- Response: 40Hz-4.2kHz
- Sensitivity: 97dB @ 50Hz-125Hz
- Power: 600W 8Ω
- Environmental: IP-X3, Optional IP-55 or IP-56
- Suspension: M10 x13



ASB6112
HIGH POWER COMPACT 300mm (12in) SUBWOOFER SYSTEM

The ASB6112 compact subwoofer system is comprised of one 300mm (12in) JBL Differential Drive 2263H woofer. Black DuraFlex™ finish. White available on request.

- Response: 35Hz-1kHz
- Sensitivity: 96dB
- Power: 700W 8Ω
- Environmental: IP-X3, Optional IP-55 or IP-56
- Suspension: M10 x16

ASB6115
HIGH POWER LIGHTWEIGHT 380mm (15in) SUBWOOFER

The ASB6115 subwoofer system is comprised of one 380mm (15in) JBL Differential Drive 2265H-1 woofer in a vented, front-loaded enclosure. This system is for ground-stacked or suspended applications in combination with other AE series products. Black DuraFlex™ finish. White available on request.

- Response: 32Hz-1kHz
- Sensitivity: 97dB @ 35Hz-400Hz
- Power: 675W 8Ω
- Environmental: IP-X3, Optional IP-55 or IP-56
- Suspension: M10 x16

ASB6125
HIGH POWER LIGHTWEIGHT DUAL 380mm (15in) SUBWOOFER

The ASB6125 subwoofer system is comprised of two 380mm (15in) JBL Differential Drive 2265H-1 woofer in a vented, front-loaded enclosure. This system is for ground-stacked or suspended applications in combination with other AE series products. Black DuraFlex™ finish. White available on request.

- Response: 32Hz-1kHz
- Sensitivity: 100dB @ 35Hz-400Hz
- Power: 675W 8Ω x2, 1350W 4Ω
- Environmental: IP-X3, Optional IP-55 or IP-56
- Suspension: M10 x16



ASB7118
HIGH POWER ULTRA LONG EXCURSION DUAL 457mm (18in) SUBWOOFER

The ASB7118 high power subwoofer system is comprised of one 18in JBL Differential Drive 2269H ultra long excursion woofer. JBL's exclusive vented gap cooling and ultra robust composite cone ensure extra long life. Black DuraFlex™ finish. Available in White on request.

- Response: 22Hz-1kH
- Sensitivity: 96dB @ 25Hz-200Hz
- Power: 1200W 8Ω
- Environmental: IP-X3, Optional IP-55 or IP-56
- Suspension: M10 x16



ASB7128
HIGH POWER ULTRA LONG EXCURSION 457mm (18in) SUBWOOFER

The ASB7128 high power subwoofer system is comprised of two 457mm (18in) JBL Differential Drive 2269H ultra long excursion woofers. JBL's exclusive vented gap cooling and ultra robust composite cone ensure extra long life. Black DuraFlex™ finish. Available in White on request.

- Response: 20Hz-1kHz
- Sensitivity: 99dB @ 25Hz-200Hz
- Power: 1200w 8Ω x2, 2400w 4Ω
- Environmental: IP-X3, Optional IP-55 or IP-56
- Suspension: M10 x16



ASB4128
MEDIUM POWER DUAL 457mm (18in) SUBWOOFER

The ASB4128 subwoofer system is comprised of two 18in JBL 2042H woofers in a vented, front-loaded configuration. The deep cabinet allows for extended low frequency bandwidth with minimal frontal profile. Black DuraFlex™ finish. Available in White on request.

- Response: 30Hz-1kHz
- Sensitivity: 103dB @ 30Hz-200Hz
- Power: 300W 8Ω x2, 600W 4Ω
- Environmental: IP-X3, Optional IP-55 or IP-56
- Suspension: M10 x12



ASB6118
HIGH POWER 457mm (18in) SUBWOOFER SYSTEM

The ASB6118 subwoofer system is comprised of one 458mm (18in) JBL 2242H SVG woofer in a vented, front-loaded configuration. Black DuraFlex™ finish. Available in White on request.

- Response: 28Hz- 1kHz
- Sensitivity: 98dB @ 30Hz-100Hz
- Power: 800W 8Ω
- Environmental: IP-X3, Optional IP-55 or IP-56
- Suspension: M10 x12



ASB6128
HIGH POWER DUAL 457mm (18in) SUBWOOFER

The ASB6128 subwoofer system is comprised of two 457mm (18in) JBL 2242H SVG woofers in a vented, front-loaded configuration. The deep cabinet allows for extended low frequency bandwidth with minimal frontal profile. Black DuraFlex™ finish. Available in White on request.

- Response: 28Hz-1kHz
- Sensitivity: 102dB @ 30Hz-100Hz
- Power: 800W 8Ω x2, 1600W 4Ω
- Environmental: IP-X3, Optional IP-55 or IP-56
- Suspension: M10 x12



AE Application Engineered™
Expansion Series Loudspeakers.

EXPANSION SERIES LOW COST LOUDSPEAKERS

The AE Expansion series is designed for use in a variety of applications. All models are equipped with multiple M10 attachment points and additional installation-friendly features and utilise a rugged grille design and system appearance suitable for nearly all indoor environments.

The AE Expansion Series includes six 2-way full-range systems and two subwoofer models. The full-range systems include fourteen M10 suspension points and four M8 mounting points for use when a wall mount bracket is required. The subwoofer models include 12 M10 suspension points. All models are available in both black and white textured coatings and are intended for indoor use. The line includes optional U-brackets and a wall mount bracket accessory for all full-range models.

These low-cost systems are a perfect choice for projects including bars, restaurants, clubs, lounges, worship facilities, gymnasiums, retail spaces, and education facilities. Their compact size provides opportunities for system designers to satisfy most architectural requirements.

AC895
TWO-WAY FULL-RANGE LOUDSPEAKER WITH 1 X 203mm (8IN) LF

AC895 is a compact 2-way full-range loudspeaker system comprised of one 209mm (8in) low frequency driver and one 25mm (1in) exit/25mm (1in) voice-coil compression driver. The rotatable PT™ Progressive Transition waveguide provides 90° by 50° coverage in vertical cabinet orientation. Highslope passive crossovers minimise band overlap and well-controlled off axis response. Textured Black paint finish. Available in White on request.

- Dispersion: 90°x 50° HxV
- Response: 70Hz-20kHz
- Sensitivity: 94dB
- Power: 150W 8Ω
- Suspension: M10 x18



AC195
TWO-WAY FULL-RANGE LOUDSPEAKER WITH 1 X 254mm (10IN) LF

AC195 is a compact 2-way full-range loudspeaker system comprised of one 258mm (10in) low frequency driver and one 25mm (1in) exit/35mm (1.5in) voice-coil compression driver. The rotatable PT™ Progressive Transition waveguide provides 90° by 50° coverage in vertical cabinet orientation. Highslope passive crossovers minimise band overlap and well-controlled off axis response. Textured Black paint finish. Available in White on request.

- Dispersion: 90°x 50° HxV
- Response: 68Hz-20kHz
- Sensitivity: 95dB
- Power: 200W 8Ω
- Suspension: M10 x18



AC266

TWO-WAY FULL-RANGE LOUDSPEAKER WITH 1 X 300mm (12IN) LF

A compact 2-way full-range loudspeaker system comprised of one 300mm (12in) low frequency driver and one 25mm (1in) exit/35mm (1.5in) voice-coil compression driver. The horn provides 60° by 60° coverage in vertical and horizontal orientation. High-slope passive crossovers minimise band overlap and well-controlled off axis response. Textured Black paint finish. Available in White on request.

- Dispersion: 60°x 60° HxV
- Response: 63Hz-20kHz
- Sensitivity: 97dB
- Power: 250W 8Ω
- Suspension: M10 x18



AC299

TWO-WAY FULL-RANGE LOUDSPEAKER WITH 1 X 300mm (12IN) LF

A compact 2-way full-range loudspeaker system comprised of one 300mm (12in) low frequency driver and one 25mm (1in) exit/35mm (1.5in) voice-coil compression driver. The horn provides 90° by 90° coverage in vertical and horizontal orientation. High-slope passive crossovers minimise band overlap and well-controlled off axis response. Textured Black paint finish. Available in White on request.

- Dispersion: 90°x 90° HxV
- Response: 63Hz-20kHz
- Sensitivity: 97dB
- Power: 250W 8Ω
- Suspension: M10 x18



AC566

TWO-WAY FULL-RANGE LOUDSPEAKER WITH 1 X 385mm (15IN) LF

A compact 2-way full-range loudspeaker system comprised of one 385mm (15in) low frequency driver and one 25mm (1in) exit/35mm (1.5in) voice-coil compression driver. The horn provides 60° by 60° coverage in vertical and horizontal orientation. High-slope passive crossovers minimise band overlap and well-controlled off axis response. Textured Black paint finish. Available in White on request.

- Dispersion: 60°x 60° HxV
- Response: 60Hz-20kHz
- Sensitivity: 98dB
- Power: 250W 8Ω
- Suspension: M10 x18



AC599

TWO-WAY FULL-RANGE LOUDSPEAKER WITH 1 X 385mm (15IN) LF

A compact 2-way full-range loudspeaker system comprised of one 385mm (15in) low frequency driver and one 25mm (1in) exit/35mm (1.5in) voice-coil compression driver. The horn provides 60° by 60° coverage in vertical and horizontal orientation. High-slope passive crossovers minimise band overlap and well-controlled off axis response. Textured Black paint finish. Available in White on request.

- Dispersion: 90°x 90° HxV
- Response: 60Hz-20kHz
- Sensitivity: 98dB
- Power: 250W 8Ω
- Suspension: M10 x18



AC115S

385mm (15IN) HIGH POWER SUBWOOFER

A high power subwoofer system comprised of one 385mm (15in) low frequency driver in a vented, front-loaded configuration for extended bandwidth. Textured Black paint finish. Available in White on request.

- Response: 32Hz-250Hz
- Sensitivity: 94dB
- Power: 400W 8Ω
- Suspension: M10 x12



AC118S

459mm (18IN) HIGH POWER SUBWOOFER

As per AC115S but 459mm (18in). Textured Black paint finish. Available in White on request.

- Response: 32Hz-250Hz
- Sensitivity: 95dB
- Power: 450W 8Ω
- Suspension: M10 x12



AE Application Engineered™ Compact Loudspeakers.

COMPACT LOUDSPEAKERS

An extension of the industry leading AE Series, the AE Compact family consists of high output, 2-way loudspeaker systems combining flexibility with high fidelity. Ranging from a single 133mm (5.25in) point-and-shoot box to dual 200mm (8in) loudspeaker system that are specifically designed for better serving the needs of both designers and artists alike. The ultra-compact AC15 and AC25 models include a 1in dome tweeter while the AC16, AC26, AC18, and AC28 models feature 1in exit compression drivers providing sonic clarity and crisp detail. The AC18 and AC28 featuring JBL's Progressive Transition™ Rotatable Waveguides, offer the system designer a choice of coverage patterns in either 90° x 50° or 120° x 60°.

AC15

Ultra compact enclosure with one 133mm (5.25in) LF transducer and 90° x 90° waveguide with 25mm dome tweeter. It is equipped with attachment points for a U-bracket and OmniMount® type bracket. Black DuraFlex™ finish. White available upon request.

- Dispersion: 90°x 90° HxV
- Response: 80Hz-20kHz
- Sensitivity: 86dB, D, WG
- Power: 150W 16Ω
- Suspension: M6 x2, M8 x4



AC25

With all the features of the AC15 with two 133mm (5.25in) LF transducers. Black DuraFlex™ finish. White available upon request.

- Dispersion: 90°x 90° HxV
- Response: 80Hz-20kHz
- Sensitivity: 91dB, D, WG
- Power: 225W 16Ω
- Suspension: M6 x4, M8 x4



AC16

Ultra compact enclosure with one 165mm (6.50in) LF transducer and 90° x 90° Progressive Transition™ waveguide with a 25mm exit compression driver. It is equipped with attachment points for a U-bracket and OmniMount® type bracket and standard mount adapter. Black DuraFlex™ finish. White available upon request. WRC/WRX finishes are available for extreme weather protection.

- Dispersion: 90°x 90° HxV
- Response: 55Hz-20kHz
- Sensitivity: 90dB,
- Power: 160W 16Ω
- Suspension: M6 x4, M8 x5



AC26

With all the features of the AC16 with two 165mm (6.50in) LF transducers. Black DuraFlex™ finish. White available upon request. WRC/WRX finishes are available for extreme weather protection.

- Dispersion: 90°x 90° HxV
- Response: 55Hz-20kHz
- Sensitivity: 92dB,
- Power: 180W 8Ω
- Suspension: M6 x4, M8 x6



AC18/95 & AC18/26

Compact enclosures with one 200mm (8in) LF transducer and a 90° x 50° Progressive Transition Field Rotatable Waveguide with a 25mm (1in) exit compression driver (AC18/95) or 120°x60° Progressive Transition™ Field Rotatable Waveguide with a 25mm (1in) exit compression driver (AC18/26). Equipped with U-bracket attachment points, OmniMount bracket and stand mount adaptor. Black DuraFlex™ finish. White available upon request. WRC/WRX finishes are available for extreme weather protection.

- Dispersion: 90°x 50° & 120°x 60° HxV
- Response: 52Hz-20kHz
- Sensitivity: 92dB
- Power: 250W 8Ω
- Environmental: IP-X3, Optional IP-55 or IP-56
- Suspension: M6 x4, M8 x6



AC28/95 & AC28/26

With all the features of the AC18/95 & AC18/26 with two 200mm (8in) LF transducers. Black DuraFlex™ finish. White available upon request. WRC/WRX finishes are available for extreme weather protection.

- Dispersion: 90°x 50° & 120°x 60° HxV
- Response: 53Hz-20kHz
- Sensitivity: 94dB
- Power: 375W 8Ω
- Environmental: IP-X3, Optional IP-55 or IP-56
- Suspension: M8 x10



All Weather Compact Series.

COMPACT ALL WEATHER

The AWC All Weather Compact models incorporate co-axial drivers for high output, consistent pattern control, extraordinary clarity with speech, and extended frequency response for music, all from very compact enclosures.

These models include minimally audible overload protection, 200 Watt transformers for 70V or 100V distributed systems, and can also be operated 8 ohm direct.



Nagashima Spa Land, Japan

AWC62

COMPACT ALL-WEATHER 165mm (6.5IN) TWO-WAY COAXIAL LOUDSPEAKER

The AWC62 is a compact two-way highly weather-resistant full-range loudspeaker system which is ideal for speech and music-fill in a wide variety of applications. Available in Black or Light Grey.

- Dispersion: 110° Conical
- Response: 70Hz-18kHz
- Sensitivity: 92dB, CD
- Power: 120W 8Ω (120W Tx)
- Environmental: IP-56



AWC82

COMPACT ALL-WEATHER 200mm (8IN) TWO-WAY COAXIAL LOUDSPEAKER

The AWC82 is a compact two-way highly weather-resistant full-range loudspeaker system which is ideal for speech and music-fill in a wide variety of applications. Available in Black or Light Grey.

- Dispersion: 120° Conical
- Response: 80Hz-18kHz
- Sensitivity: 94dB, CD
- Power: 200W 8Ω (200w Tx)
- Environmental: IP-56



AWC129

COMPACT ALL-WEATHER 300mm (12IN) TWO-WAY COAXIAL LOUDSPEAKER

The AWC129 is a compact two-way highly weather-resistant full-range loudspeaker system which is ideal for speech and music-fill in a wide variety of applications. Available in Black or Light Grey.

- Dispersion: 90° Conical
- Response: 55Hz-18kHz
- Sensitivity: 96dB, CD
- Power: 250W 8Ω (200w Tx)
- Environmental: IP-56



AWC159

COMPACT ALL-WEATHER 385mm (15IN) TWO-WAY COAXIAL LOUDSPEAKER

The AWC159 is a compact two-way highly weather-resistant full-range loudspeaker system which is ideal for speech and music-fill in a wide variety of applications. Available in Black or Light Grey.

- Dispersion: 90° Conical
- Response: 52Hz-18kHz
- Sensitivity: 96dB, CD
- Power: 300W 8Ω (300w Tx)
- Environmental: IP-56



AWC15LF

COMPACT ALL-WEATHER 385mm (15IN) LOW FREQUENCY LOUDSPEAKER

The AWC15LF is a compact highly weather resistant loudspeaker for augmenting the low frequency capability of a sound system, and is ideal for use with other AWC full-range loudspeakers. Available in Black or Light Grey.

- Response: 45Hz-2.2kHz
- Sensitivity: 94dB
- Power: 350W 8Ω (300w Tx)
- Environmental: IP-56



AW All Weather Series.

FULL SIZE ALL WEATHER

ALL WEATHER SERIES: EXCELLENT PROTECTION IN THE HARSHTEST ENVIRONMENTS

The AW full-size models are comprised of the JBL Differential Driver® dual voice coils and dual magnetic gap low frequency 12in and 15in woofers and the 2432H high-frequency 38mm (1.5in) exit, 75mm (3in) voice-coil compression driver. The large format Progressive Transition™ wave-guides provide excellent high-frequency coverage patterns. Waveguides are rotatable so the loudspeaker system can be used in either vertical or horizontal orientation.

Enclosures are constructed of multilayer glass composite and are heavily braced to maximize low-frequency performance. A 14-gauge stainless steel grille, backed with open cell foam and stainless steel mesh, provides excellent protection in the harshest environments. The systems are equipped with a 400W 70/100V transformer. A heavy-duty U-type mounting bracket is included and allows for easy installation on flat surfaces or in 90° corners.



Stade Saint-Symphorien, France

AW SERIES ALL WEATHER

- Weather-resistant, all fibreglass enclosure
- Differential Drive® low frequency driver
- U-Type mounting bracket included
- Variety of coverage patterns for versatile installation use
- Available in -LS model for EN54-24 compliance
- Available in Black or Light Grey

AW266/AW266-LS
AW295/AW295-LS

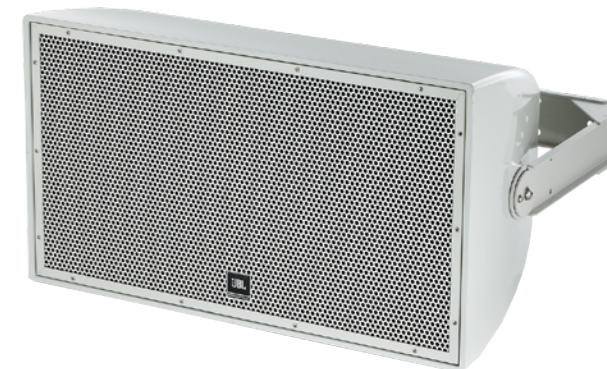

AW526/AW526-LS
AW566/AW566-LS
AW595/AW595-LS



AW266
HIGH POWER 300mm (12IN) TWO-WAY FULL-RANGE ALL-WEATHER LOUDSPEAKER

- Dispersion: 60°x 60° HxV
- Response: 40Hz-20kHz
- Sensitivity: 98dB
- Power: 500Ww 8Ω (400W Tx)
- Environmental: IP-55
- Available in Black or Light Grey

Also available: Control AW266-LS – EN54-24 Certified for life safety applications

AW295
HIGH POWER 300mm (12IN) TWO-WAY FULL-RANGE ALL-WEATHER LOUDSPEAKER

- Dispersion: 90°x 50° HxV
- Response: 40Hz-20kHz
- Sensitivity: 98dB
- Power: 500W 8Ω (400W Tx)
- Environmental: IP-55
- Available in Black or Light Grey

Also available: Control AW295-LS – EN54-24 Certified for life safety applications

AW526
HIGH POWER 380mm (15IN) TWO-WAY FULL-RANGE ALL-WEATHER LOUDSPEAKER

- Dispersion: 120°x 60° HxV
- Response: 35Hz-20kHz
- Sensitivity: 98dB
- Power: 600W 8Ω (400W Tx)
- Environmental: IP-55
- Available in Black or Light Grey

Also available: Control AW526-LS – EN54-24 Certified for life safety applications

AW566
HIGH POWER 380mm (15IN) TWO-WAY FULL-RANGE ALL-WEATHER LOUDSPEAKER/ROTATABLE HORN

- Dispersion: 60°x 60° HxV
- Response: 35Hz-20kHz
- Sensitivity: 98dB
- Power: 600W 8Ω (400W Tx)
- Environmental: IP-55
- Available in Black or Light Grey

Also available: Control AW566-LS – EN54-24 Certified for life safety applications

AW595
HIGH POWER 380mm (15IN) TWO-WAY FULL-RANGE ALL-WEATHER LOUDSPEAKER/ROTATABLE HORN

- Dispersion: 90°x 50° HxV
- Response: 35Hz-20kHz
- Sensitivity: 98dB
- Power: 600W 8Ω (400W Tx)
- Environmental: IP-55
- Available in Black or Light Grey

Also available: Control AW595-LS – EN54-24 Certified for life safety applications



CWT Series.
EXTREMELY WIDE-ANGLE COVERAGE LOUDSPEAKER SYSTEM



To provide high quality, full bandwidth sound evenly dispersed across a coverage area greater than 100°, often two speaker systems are mounted and splayed to achieve wider horizontal coverage. But this approach produces interference where the coverage patterns overlap resulting in uneven sound fields and compromised intelligibility.

JBL engineers created an innovative solution to this problem: the CWT128 loudspeaker system featuring CWT Crossfired Waveguide Technology. Drawing on its vast experience in the art and science of loudspeaker technology, JBL continually sets new standards for the audio industry while creating elegant solutions for the challenges that face all sound professionals.

CWT128
HIGH OUTPUT DUAL 200mm (8in) LOUDSPEAKER SYSTEM

The CWT128 is a compact full-range system with dual 209mm (8in) SFG drivers and a 1in exit compression driver. It is designed to provide maximum bandwidth and SPL in a single package system. Available in Black or White.

- Dispersion: 160°x 60° HxV
- Response: 71Hz-20kHz
- Sensitivity: 94dB
- Power: 450W 8Ω (110W Tx)
- Environmental: IP-X3, Optional IP-55 or IP-56
- Suspension: M8 x4, M10 x4

Crossfire Waveguide Technology

At the heart of the CWT128 is the CWT Waveguide featuring a wide coverage pattern designed to provide seamless horizontal coverage across a full 160°. Based on JBL patented technology, the CWT Waveguide is essentially split in half and loaded with two compression drivers facing in different directions. The waveguide delivers wide angle coverage in a single enclosure, exhibiting no interference, and providing remarkable off-axis response. By eliminating multiple sets of speakers that interfere with each other, the overall fidelity of the system is greatly improved, intelligibility is increased, and a more pleasant listening experience is provided for the audience.

PD500 Series.

PRECISION DIRECTIVITY SMALL FORMAT LOUDSPEAKERS 380mm (15IN) HORN-LOADED FULL-RANGE LOUDSPEAKER SYSTEM

The PD500 Series is a line of loudspeaker systems consisting of four horn-loaded 380mm (15in) 2-way systems and one dual 380mm (15in) subwoofer. The Series includes horn coverage patterns of 40° x 40°, 60° x 40°, 60° x 60°, and 90° x 50°.

These systems utilise JBL Progressive Transition™ (PT) waveguides coupled with the 2432H 38mm (1.5in) exit, 75mm (3in) voice coil compression driver and the 2031H 380mm (15in) low frequency transducer that features high sensitivity and low power compression for high continuous SPL capability. It is horn-loaded for additional sensitivity and improved pattern control. The 60° x 40° and 90° x 50° waveguides are rotatable allowing all models to be utilised in either vertical or horizontal orientation. The loudspeaker can be operated in either bi-amplified or in full passive mode. All models are available with JBL Professional WRC weather protection and WRX extreme weather protection finishes. All four full-range models are EN54-24 certified when used in full-range (not bi-amp) model.



Horizontal Array



Vertical Stack



Vertical Array

PD544

- Dispersion: 40°x 40° HxV
- Response: 50Hz-20kHz
- Sensitivity: 106dB
- Power: 300W 8Ω (Bi-Amp Switchable)

- Environmental: IP-X3, Optional IP-55 or IP-56
- Suspension: M10 x20
- Available in Black and White

PD566

- Dispersion: 60°x 60° HxV
- Response: 50Hz-20kHz
- Sensitivity: 104dB

- Power: 300W 8Ω (Bi-Amp Switchable)
- Environmental: IP-X3, Optional IP-55 or IP-56
- Suspension: M10 x20
- Available in Black and White

PD564

- Dispersion: 60°x 40° HxV
- Response: 50Hz-20kHz
- Sensitivity: 105dB

- Power: 300W 8Ω (Bi-Amp Switchable)
- Environmental: IP-X3, Optional IP-55 or IP-56
- Suspension: M10 x20
- Available in Black and White

PD595

- Dispersion: 90°x 50° HxV
- Response: 50Hz-20kHz
- Sensitivity: 104dB

- Power: 300W 8Ω (Bi-Amp Switchable)
- Environmental: IP-X3, Optional IP-55 or IP-56
- Suspension: M10 x20
- Available in Black and White

PD525S

HIGH OUTPUT, DUAL 380mm (15IN) LOW-FREQUENCY SUBWOOFER LOUDSPEAKER

The PD525S is a high power low frequency loudspeaker comprised of two 380mm (15in) Dual Coil - Dual Gap Differential Drive® low frequency drivers in a front-loaded, vented configuration. The trapezoidal cabinet is fitted with M10 threaded suspension points. Available in Black and White.

- Response: 28Hz-3.8kHz
- Sensitivity: 102dB @ 40Hz-1000Hz
- Power: 500W 8Ω x2, 1000W 4Ω
- Environmental: IP-X3, Optional IP-55 or IP-56
- Suspension: M10 x20



PD6000 Series.

PRECISION DIRECTIVITY MEDIUM FORMAT LOUDSPEAKERS

The PD6000 Series joins JBL's broad lineup of installed sound loudspeakers, complementing the larger PD700 mid-high cabinets with a more compact size and supplementing the smaller AE Series cabinets with higher SPL capability and larger horns for pattern control to a lower frequency. The PD6000 Series loudspeakers deliver high power and constant coverage in a low profile form. Featured across the PD6000 Series, newly developed 24 x 24in PT™ Progressive Transition mid-frequency rotatable waveguides that provide versatility, excellent pattern control with low distortion and extremely natural sound character. This is an evolution of the waveguide technology of the successful JBL Professional Application Engineered™ (AE) install series. Also incorporating sophisticated, steep-slope passive crossover networks minimise band overlap, further enhancing off-axis pattern control. User accessible internal switches allow for a fully active crossover. Optional Weather Protection treatment is available.

PD6200

200MM (8in) HIGH-OUTPUT MID-HIGH LOUDSPEAKER SYSTEM

- Response: 200Hz-18kHz
- Sensitivity: 109dB
- Power: 300W 8Ω (Bi-Amp Switchable)
- Environmental: IP-X3, Optional IP-55 or IP-56
- Suspension: M10 x20
- Black DuraFlex™ finish, available in White on request

- Available models:**
- PD6200/43 (40° x 30°)
 - PD6200/64 (60° x 40°)
 - PD6200/66 (60° x 60°)
 - PD6200/95 (90° x 50°)



PD6212

300mm (12in) FULL-RANGE TWO-WAY LOUDSPEAKER SYSTEM

- Response: 80Hz-18kHz
- Sensitivity: 106dB
- Power: 300W 8Ω (Bi-Amp Switchable)
- Environmental: IP-X3, Optional IP-55 or IP-56
- Suspension: M10 x20
- Black DuraFlex™ finish, available in White on request

- Available models:**
- PD6212/43 (40° x 30°)
 - PD6212/64 (60° x 40°)
 - PD6212/66 (60° x 60°)
 - PD6212/95 (90° x 50°)



PD6322

DUAL 300MM (12in) FULL-RANGE THREE WAY LOUDSPEAKER SYSTEM

- Response: 41Hz-17kHz
- Sensitivity: LF 96dB, MHF 109dB
- Power: LF 1200W 4Ω, MHF 300W 8Ω (Tri-Amp Switchable)
- Environmental: IP-X3, Optional IP-55 or IP-56
- Suspension: M10 x20
- Black DuraFlex™ finish, available in White on request

- Available models:**
- PD6322/43 (40° x 30°)
 - PD6322/64 (60° x 40°)
 - PD6322/66 (60° x 60°)
 - PD6322/95 (90° x 50°)



PD5122

DUAL 300MM (12in) HIGH-POWER LOW FREQUENCY MODULE

The PD5122 is intended for use as a flown or ground supported, high power low frequency module used in conjunction with mid/high-only or fullrange systems of the PD5000 series. Black DuraFlex™ finish, available in White on request.

- Response: 41Hz-1kHz
- Sensitivity: 96dB @ 60Hz-250Hz
- Power: 600W 8Ω x2, 1200W 4Ω
- Environmental: IP-X3, Optional IP-55 or IP-56
- Suspension: M10 x20

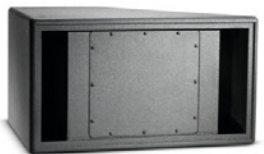

PD5125

DUAL 380MM (15in) HIGH-POWER LOW FREQUENCY MODULE

The PD5125 is a high power low frequency loudspeaker comprised of two 380mm (15in) VGC™ Vented Gap Cooled low frequency drivers in a front-loaded, vented configuration. The trapezoidal cabinet is fitted with M10 threaded suspension points. Black DuraFlex™ finish, available in White on request.

- Response: 37Hz-2.5kHz
- Sensitivity: 103dB @ 50Hz-125Hz
- Power: 600W 8Ω x2, 1200W 4Ω
- Environmental: IP-X3, Optional IP-55 or IP-56
- Suspension: M10 x20



PD700i Series.

PRECISION DIRECTIVITY LARGE FORMAT LOUDSPEAKERS

One of the challenges in large arenas, stadiums, houses of worship and performance spaces is to provide quality sound to every seat with the volume and clarity demanded by today's sporting events, concerts, and special events. The Precision Directivity™ (PD700i and PD700i-215) line of speakers provides exactly that. The PD700i models are greatly improved over their hugely successful predecessors, the PD700 Series, with upgraded mid-frequency and high-frequency components. Two new additions further enhance the capabilities of system designers by adding full-range capabilities by adding two low-frequency drivers to the mid-high models. This allows contractors and consultants to design a fully integrated sound system that solves the audio challenges inherent to these types of large installations. Optional Weather Protection treatment is available.

PD743i

VERY HIGH OUTPUT MID-HIGH LOUDSPEAKER SYSTEM

The PD743i Precision Directivity™ loudspeaker provides high-impact sound reinforcement at throw distances that are beyond the reach of traditional single-driver designs. A single module produces greater than 104dB SPL (continuous) at distances of 50m (165 ft). The PD743i-215 may be used in clusters with other PD family modules or singly as part of a distributed system. Black DuraFlex™ finish, available in White on request.

- Dispersion: 40°x 30° HxV
- Response: 200Hz-19.5kHz
- Sensitivity: 110dB
- Power: 400W 4Ω
- Environmental: IP-X3, Optional IP-55 or IP-56
- Suspension: M10 x32

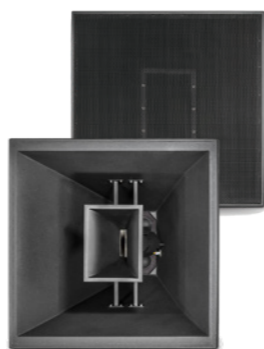

PD743i-215

VERY HIGH OUTPUT FULL-RANGE LOUDSPEAKER SYSTEM

- Dispersion: 40°x 30° HxV
- Response: 36.5Hz-19.5kHz
- Sensitivity: LF 103dB, MHF 110dB
- Power: LF 1000W 4Ω, MHF 400W 4Ω (Tri-Amp Switchable)
- Environmental: IP-X3, Optional IP-55 or IP-56
- Suspension: M10 x52
- Black DuraFlex™ finish, available in White on request



PD764i

VERY HIGH OUTPUT MID-HIGH LOUDSPEAKER SYSTEM

The PD764i-215 Precision Directivity™ loudspeaker provides high-impact sound reinforcement at throw distances that are beyond the reach of single-driver designs. A single module produces greater than 104dB SPL (continuous) at distances of 50m (165 ft). The PD764i-215 may be used in clusters with other PD family modules or singly as part of a distributed system. Black DuraFlex™ finish, available in White on request.

- Dispersion: 60°x 40° HxV
- Response: 200Hz-19.5kHz
- Sensitivity: 110dB
- Power: 400W 4Ω
- Environmental: IP-X3, Optional IP-55 or IP-56
- Suspension: M10 x28

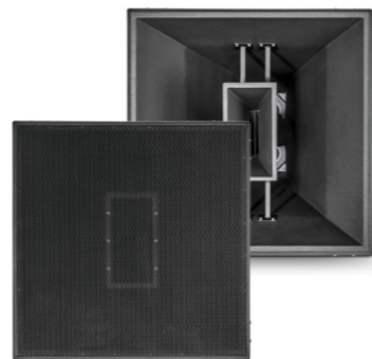

PD764i-215

VERY HIGH OUTPUT FULL-RANGE LOUDSPEAKER SYSTEM

- Dispersion: 60°x 40° HxV
- Response: 36.5Hz-19.5kHz
- Sensitivity: LF 103dB, MHF 110dB
- Power: LF 1000W 4Ω, MHF 400W 4Ω (Tri-Amp Switchable)
- Environmental: IP-X3, Optional IP-55 or IP-56
- Suspension: M10 x52
- Black DuraFlex™ finish, available in White on request

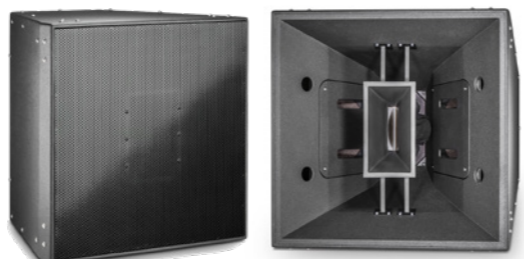

INSTALLED AUDIO



Nakhon Ratchasima Sports Complex, Thailand

VLAi Series.

LARGE FORMAT VARIABLE LINE ARRAY SPEAKERS

JBL VLAi Series includes six large format horn-loaded modules with three horizontal horn coverage patterns (30°, 60°, and 90°). This horn-loaded modular concept provides the designer additional flexibility to vary the horizontal pattern within a vertical array by incorporating different modules with wider or narrower coverage patterns while still maintaining vertical directivity.

The JBL VLAi Series uses proven JBL components with patented Differential Drive® technology. The mid and high frequency sections are horn-loaded for maximum sensitivity and optimum pattern control. The midrange section features 2169H cone midrange compression drivers with an 8in cone diameter and dual 3in voice coils. The high-frequency section features large format 2432H compression drivers with 3in voice coil. The low-frequency section features JBL's 2265H-1 Differential Drive® dual voice coil dual gap 15in woofer. This woofer features neodymium magnet and ultra-robust cone for extra-long life.

Enclosures feature 16mm (5/8in) exterior grade 12-ply birch plywood. Grills are powder coated 14 gauge acoustically transparent perforated steel. For outdoor applications JBL offers two standard levels of weather resistance. WRC is for outdoor placement where the loudspeaker will be sheltered from direct exposure. WRX is for direct exposure or more extreme environments.



VLA301i

THREE-WAY FULL RANGE LOUDSPEAKER

- Dispersion: 30° x 5° HxV (Varies with array length)
- Response: 39Hz-19kHz
- Sensitivity: LF 99dB, MF 105dB, HF 112dB
- Power: LF 1000W 4Ω, MF 400W 4Ω, HF 160W 16Ω
- Environmental: IP-X3, Optional IP-55 or IP-56
- Suspension: M10 x16
- Available in Black, available in White upon request

VLA301Hi

HIGH OUTPUT VERSION

- Dispersion: 30° x 5° HxV (Varies with array length)
- Response: 39Hz-19kHz
- Sensitivity: LF 99dB, MF 112dB, HF 115dB
- Power: LF 1000W 4Ω, MF 550W 8Ω, HF 300W 4Ω
- Environmental: IP-X3, Optional IP-55 or IP-56
- Suspension: M10 x16
- Available in Black, available in White upon request

VLA601i

THREE-WAY FULL RANGE LOUDSPEAKER

- Dispersion: 60° x 8° HxV (Varies with array length)
- Response: 41Hz-20kHz
- Sensitivity: LF 99dB, MF 107dB, HF 111dB
- Power: LF 1000W 4Ω, MF 400W 4Ω, HF 160W 16Ω
- Environmental: IP-X3, Optional IP-55 or IP-56
- Suspension: M10 x16
- Available in Black, available in White upon request

VLA601Hi

HIGH OUTPUT VERSION

- Dispersion: 60° x 8° HxV (Varies with array length)
- Response: 41Hz-20kHz
- Sensitivity: LF 99dB, MF 104dB, HF 114dB
- Power: LF 1000W 4Ω, MF 550W 8Ω, HF 300W 4Ω
- Environmental: IP-X3, Optional IP-55 or IP-56
- Suspension: M10 x16
- Available in Black, available in White upon request

VLA901i

THREE-WAY FULL RANGE LOUDSPEAKER

- Dispersion: 90° x 10° HxV (Varies with array length)
- Response: 41Hz-20kHz
- Sensitivity: LF 98dB, MF 106dB, HF 109dB
- Power: LF 1000W 4Ω, MF 400W 4Ω, HF 160W 16Ω
- Environmental: IP-X3, Optional IP-55 or IP-56
- Suspension: M10 x16
- Available in Black, available in White upon request

VLA901Hi

HIGH OUTPUT VERSION

- Dispersion: 90° x 10° HxV (Varies with array length)
- Response: 41Hz-20kHz
- Sensitivity: LF 98dB, MF 102dB, HF 110dB
- Power: LF 1000W 4Ω, MF 550W 8Ω, HF 300W 4Ω
- Environmental: IP-X3, Optional IP-55 or IP-56
- Suspension: M10 x16
- Available in Black, available in White upon request

VLA Compact Series Line Array.

SMALL-FORMAT PROFESSIONAL SOUND SYSTEMS

The Variable Line Array (VLA) Compact Series is a line array loudspeaker solution built upon the industry-leading VLA line array solution. Designed to fill the needs of system designers for installations requiring the long-throw capabilities of the VLA in a more compact line array solution, the VLA Compact offers advanced audio capabilities, out-of-the-box IP55-rated weather protection and a fibreglass enclosure for stadiums and arenas and any other project in need of compact, high-powered line arrays.

The modular design concept of the VLA Compact Series offers additional flexibility to vary the horizontal pattern within a vertical array by incorporating different modules with wider or narrower coverage patterns while still maintaining the vertical directivity. This provides the system designer the ability to build line array systems for large venue applications or to design smaller line array systems for use as distributed clusters in arenas, domed stadiums and larger performance spaces, including houses-of-worship.

VLA Compact is designed specifically for permanent installation applications requiring even coverage, high intelligibility and audio levels capable of overcoming crowd noise. As a fundamental design element, VLA Compact Series offers large format horn-loaded modules to provide broad bandwidth horizontal directivity and an increase in sensitivity. The full-range speakers include dual 2261 10in Differential Drive® 3in voice coil low frequency drivers, with 65° and 100° horizontal coverage options available. The VLA-C125S subwoofer has dual 2267H 15in Differential Drive® woofers.



VLA-C265

TWO-WAY FULL RANGE LOUDSPEAKER

The VLA-C265 uses JBL proven technology components. The high frequency section is horn-loaded for maximum sensitivity and optimum pattern control and features three D2415 drivers featuring 1.5in diameter annular diaphragms, 1.5in voice coils, and neodymium motors. The low-frequency section utilises dual 2261 10in Differential Drive® 3in voice coil drivers.

Enclosures feature multi-layer reinforced fibreglass and steel end-panels. Grilles are zinc plated, powder coated 14-gauge perforated steel with an acoustically transparent black grill cloth backing, a hydrophobic mesh underlayer, and a waterproof rail system.

The rigging system is inherent to the design of the system. Inter-box angles are selected when the array is assembled. Other accessories include a rigging frame, pull-back bar, and a cardioid kit for the sub.

- Available in Black and Grey.
- Dispersion: 65° x 10° HxV (Varies with array length)
- Response: 85Hz-19kHz
- Sensitivity: 102dB,
- Power: 400W 8Ω (Bi-Amp Switchable)
- Environmental: IP-55
- Suspension: M10 x8 (array rigging included)

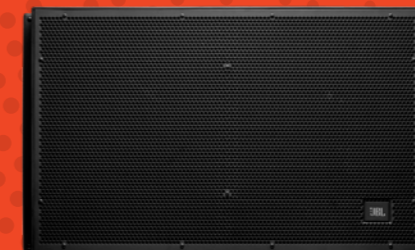
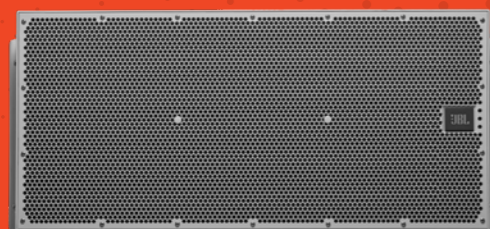

VLA-C2100

TWO-WAY FULL RANGE LOUDSPEAKER WITH 2 X 10IN DIFFERENTIAL DRIVE® LF

The VLA-C2100 uses JBL proven technology components. The high frequency section is horn-loaded for maximum sensitivity and optimum pattern control and features three D2415 drivers featuring 1.5in diameter annular diaphragms, 1.5in voice coils, and neodymium motors. The low-frequency section utilises dual 2261 10in Differential Drive® 3in voice coil drivers. Enclosures feature multi-layer reinforced fibreglass and steel end-panels. Grilles are zinc plated, powder coated 14-gauge perforated steel with an acoustically transparent Black grille cloth backing, a hydrophobic mesh underlayer, and a waterproof rail system. The rigging system is inherent to the design of the system. Inter-box angles are selected when the array is assembled. Other accessories include a rigging frame, pull-back bar, and a cardioid kit for the sub. Available in Black and Grey.

- Dispersion: 100° x 15° HxV (Varies with array length)
- Response: 86Hz-18kHz
- Sensitivity: 102dB,
- Power: 400W 8Ω (Bi-Amp Switchable)
- Environmental: IP-55
- Suspension: M10 x8 (array rigging included)

VLA-C125S

DUAL 380MM (15IN) SUBWOOFER

The VLA-C125S uses JBL proven technology components, featuring dual 380mm (15in) Differential Drive® transducers. Enclosures feature multi-layer reinforced fibreglass and steel end-panels. Grilles are zinc plated, powder coated 14-gauge perforated steel with an acoustically transparent Black grille cloth backing, a hydrophobic mesh underlayer, and a waterproof rail system.

The rigging system is inherent to the design of the system. Inter-box angles are selected when the array is assembled. Other accessories include a rigging frame, pull-back bar, and a cardioid kit. Available in Black and Grey.

- Response: 52Hz-210Hz
- Sensitivity: 98dB
- Power: 800W 8Ω
- Environmental: IP-55
- Suspension: M10 x8 (array rigging included)

VRX900 Series.

SMALL-FORMAT PROFESSIONAL SOUND SYSTEMS

Delivering extraordinary power handling, clarity and flexibility, the VRX900 Series Constant Curvature line array loudspeakers feature the hallmark of all JBL products—stunning, legendary JBL sound. Designed to address the growing need for a small-format professional sound system, JBL developed the VRX900 Series for sound rental companies and fixed installations, along with musicians and DJ's looking for the ultimate in performance and portability. Providing the performance of high end line arrays in compact 8- and 12-inch formats, including a powered 12-inch format, VRX900-Series solutions are affordable, flexible and offer outstanding coverage and coherence.

Leveraging technology and components from the JBL VERTEC® Series line arrays, but with a more compact form factor, the VRX900 Series is perfectly suited for use in smaller venues and small to medium sound reinforcement projects. Despite their smaller-scale applications, VRX900 Series Constant Curvature Line Arrays are designed and built to the same high standards as the VERTEC line and uses the same advanced, concert-proven drivers. JBL's VRX900 Series speakers deliver extraordinary power handling, clarity, flexibility and, of course, stunning JBL sound in an attractive, easy to handle and affordable package.



- Constant curvature line array system for an easy to use controlled, coherent coverage pattern.
- High performance, lightweight neodymium Differential Drive Woofers
- Powered by high performance, ultra-compact Crown Class-D amplification
- Simplified rigging and quick connections ensure fast setup and takedown
- Constructed with premium birch plywood and coated in JBL's rugged DuraFlex finish
- VRX Array Tool available for the user to understand and properly deploy the array.

VRX915M

380mm (15in) TWO-WAY FLOOR MONITOR

Dedicated, compact and lightweight 380mm two-way touring class floor monitor using JBL's latest neodymium transducers. Available in Black DuraFlex™.

- Dispersion: 50°x 90° HxV
- Response: 60Hz-20kHz
- Sensitivity: 98dB
- Power: 600W* 8Ω (Bi-Amp Switchable)



VRX915S

380mm (15in) COMPACT HIGH POWER SUSPENDABLE SUBWOOFER

The VRX915S is a compact, high power suspendable subwoofer system containing a 2265G-1 neodymium magnet, patented Differential Drive®, 15in woofer in a front-loaded, vented enclosure. Available in Black DuraFlex™.

- Arrays with VRX928LA
- Response: 35Hz-250Hz
- Sensitivity: 91dB
- Power: 800W* 4Ω
- Suspension: Integrated array rigging or M10 x8. M20 pole socket



VRX928LA

200mm (8in) TWO-WAY COMPACT LINE ARRAY SPEAKER SYSTEM

Designed for use in arrays of up to six units. Ideal when line array performance is needed but the venue size doesn't call for the very long-throw characteristics of the larger VRX932LA. Available in Black DuraFlex™.

- Dispersion: 100° x 15° HxV (Varies with array length)
- Response: 70Hz-20kHz
- Sensitivity: 90dB
- Power: 400W* 8Ω (Bi-Amp Switchable)
- Suspension: Integrated array rigging or M10 x4 Dual angle pole socket



VRX932LA-1

300mm (12in) TWO-WAY COMPACT LINE ARRAY SPEAKER SYSTEM

Lightweight compact and designed for use in arrays of up to six units. Available in Black DuraFlex™.

- Dispersion: 100° x 15° HxV (Varies with array length)
- Response: 57Hz-20kHz
- Sensitivity: 95dB
- Power: 800Ww* 8Ω (Bi-Amp Switchable)
- Suspension: Integrated array rigging or M10 x4. Dual angle pole socket



VRX932LAP

300mm (12in) TWO-WAY COMPACT LINE ARRAY SPEAKER SYSTEM

Powered version of VRX932LA-1. Available in Black DuraFlex™.

- Dispersion: 100° x 15° HxV (Varies with array length)
- Response: 57Hz-20kHz
- Power: 1750-watts Peak, 875-watts Continuous, Class D
- Suspension: Integrated array rigging or M10 x4. Dual angle pole socket



VRX918S

457mm (18in) COMPACT HIGH POWER SUSPENDABLE SUBWOOFER

The VRX918S is a compact, high power suspendable subwoofer system containing a 2268H neodymium magnet, patented Differential Drive®, 18in woofer in a front-loaded, vented enclosure. Available in Black DuraFlex™.

- Arrays with VRX932LA
- Response: 31Hz-250Hz
- Sensitivity: 95dB
- Power: 800W* 8Ω
- Suspension: Integrated array rigging or M10 x4 M20 pole socket



VRX918SP

457mm (18in) POWERED HIGH POWER SUSPENDABLE SUBWOOFER

The VRX918SP is a powered, suspendable subwoofer system containing a 2268FF neodymium magnet, patented Differential Drive®, 18in woofer in a front-loaded, vented enclosure. The VRX918SP was designed specifically for use in arrays with the VRX932LAP Line Array speaker and VRX-AF Array Frame. In addition it may also be used in arrays consisting entirely of VRX918SP subwoofers. Available in Black DuraFlex™.

- Arrays with VRX932LAP
- Response: 31Hz-250Hz
- Power: 1500W Peak, 750W Continuous, Class D
- Suspension: Integrated array rigging or M10 x4. M20 pole socket



*2 Hour IEC with 6dB Crest.

VTX A-Series.

SCALABLE, SMART AND EFFICIENT

The VTX A-Series was designed from scratch to address not only audio performance, but the full scope of challenges faced by tour sound professionals, rental companies, FOH engineers and live production crews. Want unparalleled performance, sensitivity and coverage? JBL's proprietary transducer technology and high-frequency waveguides deliver. Want streamlined deployment and setup? A patented JBL rigging mechanism and redesigned suspension system make it happen.



VTX A6

SUB-COMPACT DUAL 6.5-INCH LINE ARRAY ELEMENT

The A6, JBL's smallest VTX line array product to date, brings flagship VTX A Series performance to a subcompact form factor. The fully passive, two-way line array element is a versatile solution for small to mid-size rental houses, corporate events, theaters, clubs, houses of worship or anyone who demands superior sound reinforcement.

- 3-inch polymer annular-diaphragm compression driver and integrated waveguide
- Custom 6.5-inch woofers
- (RBI) horn design provides 120° horizontal dispersion
- Efficient passive crossover network



VTX A8

DUAL 8-INCH COMPACT LINE ARRAY LOUDSPEAKER

The A8 combines two 8in woofers, four 3.5in midrange drivers and two 2in high-frequency drivers in a single low-profile cabinet. Proprietary double-flared low-frequency ports, precisely calculated for greater low-frequency performance extend the usable operating range down to 49Hz.

- 3-way bi-amp design
- Differential Drive™ woofers and Slip Stream™ ports
- Radiation Boundary Integrator® (RBI) design
- Built-in MF/HF passive network
- Compact, lightweight design



VTX A12 & A12W

DUAL 12-INCH LINE ARRAY LOUDSPEAKER

VTX A12 was designed from scratch to address the unique challenges of rental companies, FOH engineers and tour sound production crews. Next-generation JBL transducer technology and a high-frequency waveguide design deliver unmatched performance, sensitivity and coverage.

- Innovative HF section
- Redesigned Radiation Boundary Integrator® (RBI) design
- Next Generation LF section

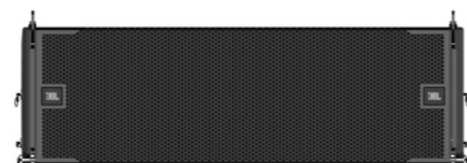

Inside The Innovations

For VTX A-Series, next-generation transducers were engineered from the ground up by JBL for linear performance, high output and consistent coverage. Together, their custom-designed low-, mid-, and high-frequency sections deliver the highest output per weight in their class, with improved low-frequency extension and controlled directivity that ranges from 90–120 degrees. Physical design refinements integrate more drivers into smaller, lighter cabinets for reduced overall system weight and truck-friendly dimensions. A revolutionary auto-locking rigging and suspension system speeds deployment time. It all adds up to big-system-JBL sound in our most convenient and comprehensive offering to date.

Advanced Speaker Components

- High Frequency—Combines the HF phasing plug and waveguide in a single part
- Radiation Boundary Integrator—Integrates mid-frequency woofers with the high-frequency horn
- Low Frequency—A lightweight neodymium low-frequency woofer
- Suspension System—Patented auto-locking mechanism
- Grill Design—Minimizes exposed components

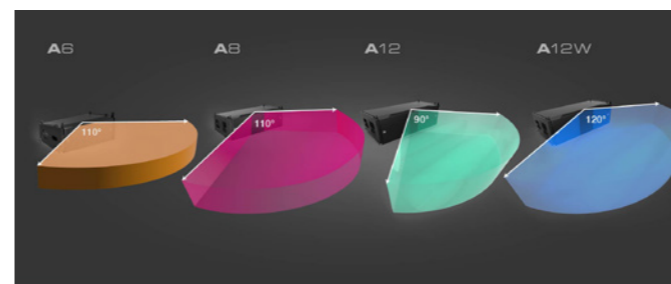

Smooth, Even Coverage In Any System Configuration

VTX A-Series speakers adhere tightly to their dispersion patterns, which keeps the sound where you want it: off the stage and in the audience. All four models feature the same HF compression driver, waveguide technology and other components, ensuring uniform, consistent voicing and coverage and providing the flexibility to design systems that match the needs of any listening environment.



Innovative Rigging And Transport

To facilitate fast deployment, array elements are stacked four per vertical transporter (VT) cart in a 10-degree collapsed position. A patented auto-locking mechanism lets users select angles while components are on the ground; once the system is suspended, the mechanism automatically locks cabinet angles in designated positions. Angles can be set in increments as low as 0.25 degrees simply by pulling and placing a pin—it's that easy.

Advanced High Frequency Section

The high-frequency (HF) section found in the VTX A-Series combines the HF phasing plug and waveguide into a single part, which increases sensitivity and provides better tolerances while reducing distortion and overall weight.

Acoustically Integrated Mids And Highs

VTX A-Series features JBL's patented Radiation Boundary Integrator (RBI), which integrates mid-frequency drivers in the high-frequency waveguides for a seamless transition across each band and maximum transducer density.

Superior Low Frequency Extension

The VTX A-Series delivers big low-frequency performance thanks to its custom lightweight, neodymium low-frequency woofers. Transducer design is based around JBL's Differential Drive technology, a dual-voicecoil, dual-gap configuration that maximizes excursion, power handling and sensitivity in a compact footprint. The resulting sound quality is extraordinarily transparent, even at very high SPLs. Coupled with flared, exponential low-frequency ports, A-Series' new LF drivers provide low-frequency extension that's unmatched in their class.

VTX V-Series. PERFORMANCE LINE ARRAY SYSTEM

Of all the achievements JBL has made over the years, the VTX V-Series stands as a milestone in the practical application of creative engineering because of their high levels of performance, system integration and user friendliness—and years of high profile tours, festivals, and installations can attest to that fact. The V-Series evolved from JBL's continued effort to deliver more powerful, more compact, lightweight and flexible sound reinforcement systems for portable and fixed-venue system operators alike.



VTX V25-II FULL SIZE 3-WAY LINE ARRAY

The VTX V25-II includes a new 4th generation waveguide which improves long throw performance, wavefront control, and is an improved power match for the Crown IT4x3500HD. The transducer complement for VTX V25-II is two 2000W 15in Differential Drive® woofers mounted in die cast aluminum baffles, four 8in Differential Drive midrange transducers firing through a patented (RBI Radiation Boundary Integrator®), and three revolutionary D2 Dual-Diaphragm Dual-Voice-Coil Compression Drivers loaded onto the newly designed waveguide.

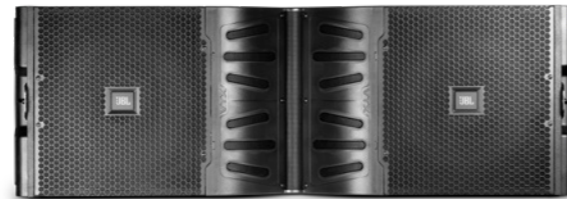

- D2 Dual Diaphragm, Dual Voice Coil Compression Drive
- RBI (Radiation Boundary Integrator®)
- Patented JBL S.A.F.E.™ Suspension System
- Aluminum front baffles

- Available models:**
- VTX V25-II**
Full Size 3-Way Line Array with Fixed Angle ASM Suspension
 - VTX V25-II-CS**
Full Size 3-Way Line Array with Compression Suspension System

VTX V20 THREE-WAY LINE ARRAY ELEMENT

VTX V20 features the advanced technology and extraordinary performance of the groundbreaking VTX V25 in a smaller format, high power density 3-way system complemented by a new suspension system that provides efficient transport, fast setup and precise configuration. All VTX V20 components have been specifically engineered to provide stable 105 degree horizontal coverage and effective line source array coupling in the vertical plane while delivering linear, transparent sound up to surprisingly high output levels for its diminutive size.

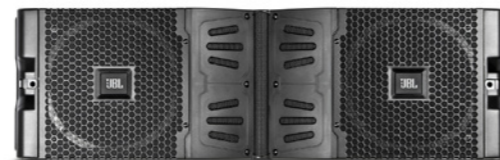

- Differential Drive Technology
- Small format D2 Dual Compression Driver
- ASM Suspension System



The Realization Of Engineering Excellence

At the heart of VTX is the D2 Dual Driver, a revolutionary device developed by JBL that dramatically improves the sound and performance of high frequencies. Merging two compression drivers into a single, compact transducer with a single acoustical output, the D2 Dual Driver utilizes two voice coils, each with its own lightweight, polymer, annular diaphragm, its own magnet assembly, and its own specialized phasing plug. Instead of the large and 'heavy' single voice coil metal dome diaphragm of conventional compression drivers, D2 is driven by two light but strong voice coils, two motive 'forces' instead of one, acoustically connected to a single exit chamber. The two annular polymer diaphragms have the same radiating area as a conventional single dome, and overall output and power handling are dramatically increased due to the lower moving mass and enhanced heat transfer obtained with two separate voice coils.

The result is a compact compression driver with dramatically improved efficiency, power handling, smoother, extended high frequency response and significantly lower levels of nonlinear distortion. Well-validated by objective measurements, D2's performance has also gone through exhaustive subjective listening tests, demonstrating its superior sound quality compared to traditional metallic, mono structure drivers. D2 provides an extreme output advantage over conventional systems with significantly higher array power density. Compared to a conventional system, the D2 has double the number of voice coils and more than double the power handling, but with a 30% reduction in weight. This results in a dramatic increase in pure high frequency sound pressure levels in the same physical footprint.



A simple formula for success in modern audio technology is to employ the best engineers using the best methodology and tools, and always develop from the ground up—a formula that JBL has perfected for over 70 years. The result is a prolific list of audio achievements, groundbreaking technologies, revolutionary advances in the art and science of professional audio, patents and awards—many of them. It's a journey that is legendary worldwide and has positioned JBL as the world leader in professional audio.



Powerful Mid-Range 2169h 8in Transducers

The low distortion, high output design of the 2169H 8in mid-range transducers ensures superb fidelity and articulation for critical mid-range frequencies. The VTX V25 system's mid-range drivers employ JBL's exclusive Differential Drive technology for lower weight and higher output. The highly efficient cooling characteristics of the mid-range drivers ensure lower operating temperatures, greatly improved power compression characteristics, dynamic headroom and lower harmonic distortion.

Powerful Low Frequency 2267h 15in And 2269h 18in Transducers

The 2267H was specifically-designed for VTX V25 and has the same motorstructure as employed in the 2269H 18in transducer featured in both G28 and S28 subwoofers. The result? Four-inch diameter, dual voice coil, dual magnet transducers with industry-leading AES 2 hr power handling of 2000 Watts. Combined with uncompromised Crown power amplification, VTX V25 low section output is unequalled in its class and G28, S28 subwoofers provide a solid foundation for high impact, very low frequency reproduction.



S.A.F.E.™ Suspension

VTX's patented S.A.F.E. suspension system is streamlined for speed and efficiency with improved hardware for faster setup with fewer pinning operations and greater security. A custom-designed protective cover and dolly makes transport easy and the suspension process fast, efficient and safe. Vertical Transporters are also available allowing for transport of four V25 enclosures or three S28 enclosures in either front-firing or cardioid mode.

All suspension hardware is integrated into the enclosure and strategically-positioned for fast and secure operation. Front flip hinges and captive rear hinge bars utilizing a unique Angle Stop Mechanism (ASM) allow for efficient assembly that is not only secure, but antirattle. Also included is provision for mounting a Laser Sighting Module accessory for greater ease and precision in array focus and system tuning.

VTX F Series.

STUDIO MONITOR SOUND QUALITY

VTX F Series delivers studio monitor sound quality in a line of premium two-way multipurpose cabinets featuring point and shoot flexibility, uncompromised sound quality and the patented D2 Dual Diaphragm Dual Driver used in the VTX V25-II and M2 Studio Reference Monitor. VTX F Series features a premium transducer upgrade of a tried-and-tested design that has always delivered for their most demanding clients.



Nz Sound Reinforcement At Bay Dreams Festival, New Zealand

VTX F12

305mm (12in) BI-AMPLIFIED 2-WAY SYSTEM

The VTX F series is a line of multi-purpose loudspeakers designed to give sound production companies a variety of flexible options for deploying high-quality audio, either as a stand-alone FOH system, a satellite and subwoofer system (with companion VTX F18S), or on-stage floor monitor and fill speaker.

- Dispersion: 90°x50° (vertical orientation)
- Response: 51Hz-21.5kHz
- Max SPL: LF: 138dB; HF: 137dB
- Power: LF: 1,000W continuous (AES/2 hour)
- HF: 200W continuous (AES/2 hour)



VTX F15

380mm (15in) BI-AMPLIFIED 2-WAY SYSTEM

The VTX F series is a line of multi-purpose loudspeakers designed to give sound production companies a variety of flexible options for deploying high-quality audio, either as a stand-alone FOH system, a satellite and subwoofer system (with companion VTX F18S), or on-stage floor monitor and fill speaker.

- Dispersion: 90°x50° (vertical orientation)
- Response: 43Hz-21.5kHz
- Max SPL: LF: 134dB; HF: 137dB
- Power: LF: 1,000W continuous (AES/2 hour)
- HF: 200W continuous (AES/2 hour)



VTX F35

380mm (15in) HIGH PERFORMANCE DUAL 3-WAY LOUDSPEAKER

The F35 is the go-to choice for customers needing high-power side-fills, mains speakers, or a high-performance point-source solution to complement to larger VTX systems. This system has an exceptional power-to-weight ratio thanks to its lightweight, Differential Drive 15in and 8in transducers, and benefits from proven JBL technologies, including a multi-band Progressive Transition Waveguide and the high-performance D2 high-frequency driver.

- Dispersion: 90°x50° HxV
- Response: 39Hz-18kHz
- Max SPL: 143dB
- Power: LF: 2x800W continuous (IEC/100 hour)
- MF: 270W continuous (IEC/100 hour)
- HF: 100W continuous (IEC/100 hour)



VTX F18 S

458MM (18IN) COMPACT SUBWOOFER



The VTX F series is a line of multi-purpose loudspeakers designed to give sound production companies a variety of flexible options for deploying high-quality audio, either as a stand-alone FOH system, a satellite and subwoofer system (with companion VTX F18S), or on-stage floor monitor and fill speaker.

- Dispersion: 50°x 90° HxV
- Response: 60Hz-20kHz
- Sensitivity: 98dB
- Power: 600W* 8Ω (Bi-Amp Switchable)

VTX M Series.

PREMIUM TOUR-READY MONITORS

VTX M Series monitors feature high performance differential drive woofers and the large-format D2 dual-diaphragm dual voice-coil high frequency driver. The option of Single-Channel (Passive) or Dual-Channel (Bi-Amp) operation modes comes standard, allowing the user to choose the right option for the application, with no compromise in output power or performance.



SPECIFICATIONS		
Model	VTX M20	VTX M22
Coverage Pattern	60°H x 60°V	60°H x 60°V
Maximum Peak Output*	136 dB	138dB
System Power**	1250 W Continuous (IEC / 100 hour) LF: 1250 W Continuous (IEC / 100 hour) HF: 100 W Continuous (IEC / 100 hour)	1500 W Continuous (IEC / 100 hour) LF: 1500 W Continuous (IEC / 100 hour) HF: 100 W Continuous (IEC / 100 hour)
Frequency Range (-10 dB)	55 Hz - 19.5 kHz	45 Hz - 19.5 kHz
Nominal Impedance Single Channel (Passive)	4-ohm	4-ohm
Nominal impedance Dual Channel (Bi-Amp)	LF: 4-ohm HF: 8-ohm	LF: 4-ohm HF: 8-ohm
Transducers	LF: 2 x 10in HF: 1 x Dual-3in	LF: 2 x 12in HF: 1 x Dual-3in
Amplification	Crown iTech HD	Crown iTech HD
Dimensions (mm/in)	342.9 mm x 575.0 mm x 515.3 mm (13.6 in x 22.6 in x 20.3 in)	380.1 mm x 670.8 mm x 555.0 mm (15.0 in x 26.4 in x 21.8 in)



VTX M20
DUAL 10-INCH
PROFESSIONAL STAGE MONITOR



VTX M22
DUAL 12-INCH
PROFESSIONAL STAGE MONITOR

*Peak, unweighted SPL, measured under half-space conditions at 1 meter using broadband pink noise with a 10dB crest factor and specified preset.

**IEC Standard: IEC shaped noise with 6dB crest factor based on Nominal impedance and a duration of 100 hours

VTX Subwoofer Series.

UNCOMPROMISED LOW-FREQUENCY PERFORMANCE

Boasting JBL's legendary subwoofer technology innovations, VTX Subwoofers include models that feature Differential Drive® transducers that integrate a dual voice coil, dual-gap design, neodymium magnets, and carbon-fiber-based cones. JBL Slip Stream™ low-frequency port technology include proprietary double-flared ports, precision-engineered for greater low frequency extension and reduced port noise.



COACHELLA VALLEY MUSIC AND ARTS FESTIVAL, INDIO, CALIFORNIA

VTX B15 380mm (15in) COMPACT ARRAYABLE SUBWOOFER

The VTX B15 Compact Arrayable 15-inch Subwoofer extends the low-end performance of VTX full-range sound-reinforcement systems, including the VTX A6 Subcompact Dual 6.5-inch Line Array Element. The B15 is a versatile solution for production companies, touring acts, rental houses, theaters, houses of worship or anyone who demands superior sound reinforcement when space is at a premium.

- 2285H 15-inch woofer
- SlipStream double-flared ports
- Differential Drive dual-voicecoil
- Rugged, exterior-grade birch plywood
- Neutrik STX speakON NL4 connectors



VTX B18 457mm (18in) SINGLE SUBWOOFER

The VTX B18 features JBL's new 2288H 18in woofer, engineered for improved linearity, increased sensitivity and extra-long excursion. The 2288H is based on JBL's Differential Drive, dual voice coil, dual-gap technology, which delivers better heat dissipation, lower power compression and wider dynamic range than conventional single-coil designs. The B18 incorporates JBL's patented Slip Stream™ double-flared exponential low-frequency port design to improve airflow and reduce audible turbulence, even at maximum excursion.

- 2228 transducer
- SlipStream double-flared ports
- Built-in, easy to use, spring-loaded rigging system
- Front and rear NL4 connectors
- Compact design



VTX B28 457mm (18in) ARRAYABLE DUAL SUBWOOFER

The B28 boasts JBL Differential Drive transducers, an exclusive port design, and the same industrial design found in JBL's VTX A-Series products. It is equally ideal flown or ground stacked, in omnidirectional or cardioid configurations. Simple and fast rigging, a selection of accessories, and software support make the B28 an exceptional choice for rental, AV, and touring companies, as well as in high-end fixed installations.

- Linear bass response down to 25 Hz
- JBL Differential Drive woofers
- Large double-flared port
- 2-point spring-loaded rigging system
- FEA-optimized enclosure

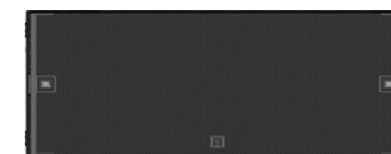

VTX S25 380mm (15in) SUSPENDABLE, CARDIOID-ARRAYABLE, DUAL SUBWOOFER

The dual 15in, cardioid-arrayable S25 subwoofer provides industry-leading very low frequency output and can be integrated with V20 with tremendous versatility, either ground-stacked or suspended in mixed arrays or standalone.

- Differential Drive Technology
- V5 System Integration



VTX S28 457mm (18in) SUSPENDABLE DUAL SUBWOOFER

VTX series dual 18in subwoofers employ two 2269H 18in transducers featuring Differential Drive technology with two voice coils, two neodymium magnets and extremely high peak-to-peak excursion capabilities to deliver extended very low frequency performance.

- 2269H Differential Drive®
- Reverse-Cardioid Arrayable
- Compatible with VTX V25 suspension
- BSS® Audio OmniDriveHD V5 Processing



SRX900 Series.

OUTSTANDING SONIC PERFORMANCE

The SRX900 Series' outstanding sonic performance is based on time-tested JBL technologies. Custom-engineered and manufactured, high-power-handling transducers deliver extremely low distortion, high fidelity and class-leading output. Precision waveguides provide accurate pattern control for intelligibility and definition that are unmatched in this category. A full suite of user-configurable DSP and design-and-management software tools provides hands-on control from a computer or mobile device, making design, deployment and control a breeze. SRX900's cabinet architecture is thoughtfully engineered for easy handling, fast rigging, minimal space displacement and streamlined transport.



SEAMLESS SOFTWARE CONTROL

SEAMLESS SOFTWARE CONTROL

The SRX900 Series' unified software suite lets users manage system design, control and deployment functions on Windows, macOS, and iOS. Use JBL LAC-3 simulation software for system design and the new, cross-platform JBL Performance application for system management; transfer rigging information via the Array Link iOS/Android companion app. A rear-panel LCD screen provides full on-speaker access to control features, making it easy for users to troubleshoot large systems or configure small systems right onscreen.



VERSATILE AND SCALABLE

VERSATILE, SCALABLE AND AFFORDABLE

The SRX900 Series offers a complete system solution, including speakers, subwoofers and accessories that support a variety of configurations and simplify storage, transport and rigging. Because systems are scalable, it's easy to start with a small investment and add components over time. SRX900 products are designed to work seamlessly with other JBL touring sound products, thanks to common voicing targets and phase characteristics.



FAST, SAFE, EASY RIGGING

FAST, SAFE, EASY RIGGING

SRX900 Series systems are designed for both portable and installed applications and can be deployed in a variety of configurations, from pole-mounted to ground-stacked to flown arrays of up to 16 cabinets. A three-point rigging system, adapted from VTX technologies, makes suspending systems safe and easy, regardless of system size or user experience level. Set splay angles on the ground; cabinets lock into place as the system is lifted. The rear rigging spine serves as an additional heatsink for added cooling. Available accessories include array frames, base plates, pole-mount and truss-clamp adapters, cases, carts and covers.

SRX906LA DUAL 165mm (6.5IN) POWERED LINE ARRAY LOUDSPEAKER

The SRX906LA is a compact, two-way, active line array element that can cover a variety of small- to mid-sized applications, including rental houses, touring artists, DJs, and installations. Built-in DSP and amplification offer a plug and play experience while providing consistency and optimum performance anywhere in the world.

- High-performance, high-density system
- High-power-handling transducers
- Built-in, passively cooled Class D amplification
- Dual Ethernet ports



SRX910LA DUAL 254mm (10IN) POWERED LINE ARRAY LOUDSPEAKER

The SRX910LA is a two-way active line array element that can cover a variety of mid to large-sized applications, including rental houses, touring artists, DJs, and installations. Built-in DSP and amplification offer a plug and play experience while providing consistency and optimum performance anywhere in the world.

- High-performance, high-density system
- High-power-handling transducers
- Built-in, passively cooled Class D amplification
- Dual Ethernet ports

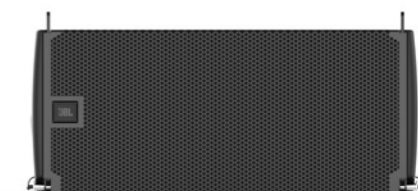

SRX918S 203mm (18IN) POWERED SUBWOOFER

The SRX918S is a single 18-inch active subwoofer designed to complement SRX900 Series full-range sound reinforcement systems. The subwoofer houses a JBL 2279-1 18-inch woofer featuring Differential Drive® – JBL's dual voice coil, dual gap technology – to deliver better heat dissipation, lower power compression, and wider dynamic range than conventional single-coil designs.

- High-performance, high-density system
- High-power-handling transducers
- Built-in, passively cooled Class D amplification
- Dual Ethernet ports

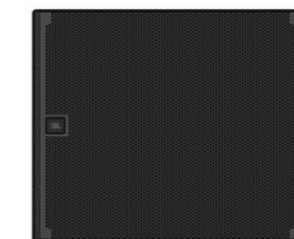

SRX928S DUAL 203mm (18IN) POWERED SUBWOOFER

The SRX928S is a dual 18-inch active subwoofer designed to complement SRX900 full-range sound reinforcement systems. The sub-woofer houses two JBL 2279-1 18-inch woofers, featuring Differential Drive® – JBL's dual voice coil, dual gap technology – to deliver better heat dissipation, lower power compression, and wider dynamic range than conventional single-coil designs.

- High-performance, high-density system
- High-power-handling transducers
- Built-in, passively cooled Class D amplification
- Dual Ethernet ports

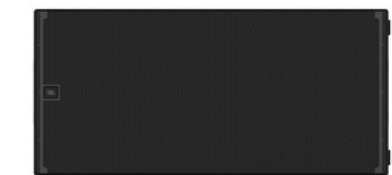

LIVE PORTABLE PA SPEAKERS

The road to the top is long and difficult. You need a PA system that is built to take it. Before you even plug it in, the EON600 endures JBL's legendary testing protocol, including 100 hours of playback at full power, and extreme environmental and drop tests. Sturdy cabinet materials, heavy-gauge grilles, and genuine JBL transducers ensure that the EON600 delivers exceptional sound for the long haul, gig after gig. Plus, integrated Bluetooth capability gives you convenient and simple wireless control.



Nam Nghi Resort's Rock Island Club, Vietnam

PRX400 Series.

PORTABLE PASSIVE LOUDSPEAKERS

PRX400 passive speakers were designed to provide the sensitivity, frequency response and power handling needed for almost any professional audio environment while still being reasonably priced. Whether you use a powered mixer or an equipment rack full of amps and signal processing, PRX400 passive speakers deliver the sound, power and bandwidth necessary to make loud music sound natural and even quiet speech intelligible. Utilising poplar and birch enclosures as well as JBL's rugged DuraFlex coating, these speakers are road tough and ready to perform in any environment.



Grille

Rugged 16-gauge grilles provide serious protection for the JBL tour tested components. Backed with acoustically transparent cloth the grilles are designed for sonic accuracy, structural strength and professional good looks.

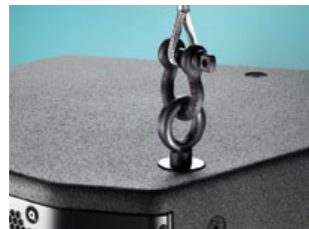

Suspension Points

Permanently mounting the PRX400 is easily managed via twelve built-in M10 suspension points constructed from 14 gauge steel. They have been tested with a yield-strength of 1000 pounds each ensuring a safe and secure mount.



Handles

Ergonomically engineered handles are made from light-weight glass-filled nylon for added strength and durability. Intelligently engineered for both balance and comfort in the hand, they make carrying, mounting and positioning each enclosure easily managed in any situation.



Pole Sockets

Built in dual-angle pole mount sockets allow the PRX412M and PRX415M to be stand mounted at different angles to accommodate the best audience coverage pattern. With a 10° down angle, the speaker can be directed down toward your audience, enhancing sound coverage and clarity.



Eye Bolts

The JBL M10 Forged Shoulder Steel Eyebolts kit contains the necessary eyebolts needed for flying and suspending most installation-ready loudspeakers.



Tri-Pod Stand

The JBL SS2BK stand is a collapsible, aluminum tri-pod stand designed exclusively for JBL pole mount speakers. Its light-weight and simple functionality make it the perfect companion to your JBL speakers.



Subwoofer Pole

The JBL SS4BK adjustable subwoofer mounting pole is the essential option for your PRX400 sub/satellite system. The pole features a safe and secure 10mm threaded end and a standard 35mm end for use in JBL pole sockets. Also available in a fixed 24in height.

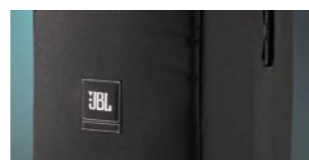

Speaker Covers

Protect your investment with a rugged, padded nylon, JBL branded cover or even a hard-shell case.

PRX412M

300mm (12in) TWO-WAY POWERED STAGE MONITOR

PRX412M is a portable, 300mm (12in), two-way speaker system designed for either main sound reinforcement or monitoring applications. Black or White DuraFlex™ finish.

- Dispersion: 90° x 50° HxV
- Response: 50Hz-20kHz
- Sensitivity: 95dB,
- Power: 300W* 8Ω
- Suspension: M10 x12. Dual angle pole socket.



PRX415M

380mm (15in) TWO-WAY PASSIVE STAGE MONITOR & LOUDSPEAKER SYSTEM

PRX415M is a portable, 380mm (15in), two-way speaker system designed for either main sound reinforcement or monitoring applications. Black or White DuraFlex™ finish.

- Dispersion: 90° x 50° HxV
- Response: 55Hz-20kHz
- Sensitivity: 98dB,
- Power: 300W* 8Ω
- Suspension: M10 x12. Dual angle pole socket.



PRX425

380mm (15in) TWO-WAY LOUDSPEAKER SYSTEM

PRX425 dual 380mm (15in), two-way is the perfect choice for DJ's and bands who need low-frequency extension from the convenience of a stand-alone cabinet. Black DuraFlex™ finish.

- Dispersion: 90° x 50° HxV
- Response: 48Hz-20kHz
- Sensitivity: 98dB,
- Power: 600w* 4Ω
- Suspension: M10 x12



PRX418S

457mm (18in) PASSIVE SUBWOOFER SYSTEM

PRX418S is an 457mm (18in) subwoofer which, when combined with the two-way models, provides a sub/sat system capable of generating 135 dB of full-range, high quality audio. Black DuraFlex™ finish.

- Response: 35Hz-250Hz
- Sensitivity: 95dB
- Power: 800w* 8Ω
- Suspension: Pole socket



EON700 Series.

ADVANCED ACOUSTIC TECHNOLOGY

Launched in 1995, JBL's best-selling EON family of PAs set the benchmark for how great a powered loudspeaker system can be. The EON700 Series represents a major step forward in innovation and technology: JBL engineers used exclusive, state-of-the-art design and measurement techniques to deliver the best-performing loudspeakers in their category, regardless of application. EON700 leverages the latest acoustic science, transducer designs, cabinet materials and advanced DSP and control technologies to deliver extraordinary performance in a fully professional, highly flexible, easy to use, portable system. With four models available, including the 10-inch EON710, the 12-inch EON712 and the 15-inch EON715 powered PA speakers and the 18-inch EON718S subwoofer, EON700 systems cover the needs of today's working musicians and sound providers.



JBL PRO CONNECT APP

Available for Android and iOS phones and tablets, JBL Pro Connect opens up a world of possibilities for hands-on control over a full-suite of PRX ONE, EON ONE MK2 and EON700 mixer, DSP, and Bluetooth features. From either landscape or portrait viewing modes, the streamlined interface makes it easy to adjust and control every feature on multiple speakers from anywhere in the room.

Iconic Acoustics, Superior Sound

JBL's advanced waveguide and transducer technologies, coupled with highly efficient amplification, ensure uniform coverage across the entire listening area, even when you push the system to the limit.

Woofers are redesigned for lower impedance and higher efficiency, an improved horn delivers a smooth off-axis beamwidth and JBL's powerful 2414H compression driver features a premium neodymium magnet for balanced response in a lightweight footprint. Speakers are powered by 1,300 (loudspeakers) or 1,500 (subwoofer) watts of ultra-efficient discrete Class D amplification, for clean, clear sound. It all adds up to superior coverage, consistency and intelligibility at any volume.

System Versatility

EON700 loudspeakers can be used as main PA speakers or floor monitors. Full-range models feature top and rear suspension points for flying speakers; rear suspension points serve as connections for fixed installations, using an optional universal yoke mount. Indexed feet molded into enclosures enable a range of acoustic configurations and secure stacking for traditional stand-up configurations and convenient storage and transport. EON718S subwoofers feature a threaded pole mount for full-range speakers and are easily stacked for cardioid configurations.

Rugged and Reliable

Full-range speakers feature FEA optimized composite enclosures, taking advantage of injection-molding and mechanical-shaping techniques for added durability without sacrificing cabinet size or performance. Subwoofers are housed in rugged 15-ply birch enclosures; computer-optimized ergonomic handles make moving boxes a breeze. Every JBL Professional product undergoes stringent testing that goes above and beyond any conditions the product would face in the real world. Our industry-leading 100-hour power test ensures longevity so musicians and audio engineers can rely on JBL components in any scenario.

Mounting Bracket

The EON700 universal yoke mount provides a robust, universal design that adheres to the most stringent weight and quality standards with built-in cable slot and adjustable angle measurements for consistent design and layout.



EON710

250mm (10in) TWO-WAY POWERED LOUDSPEAKER SYSTEM

The JBL EON710 10-inch powered loudspeaker offers an all-new acoustic package featuring a completely redesigned woofer, JBL's powerful 2414H compression driver and an optimized horn, plus a range of mounting options for the ultimate in volume and versatility in mid-size and focused live and installed applications.

- Dispersion: 100°x60° HxV
- Response: 52Hz-20kHz
- Max SPL: 125dB
- Power: 1,300W peak



EON712

300mm (12in) TWO-WAY POWERED LOUDSPEAKER SYSTEM

The JBL EON712 12-inch loudspeaker is built from the ground up for unrivaled power and performance, featuring a newly engineered woofer, JBL's 2414H compression driver and an optimized horn. Yoke- and pole-mounting accessories expand configuration options, letting users tailor systems for music venues, corporate events or worship services.

- Dispersion: 100°x60° HxV
- Response: 50Hz-20kHz
- Max SPL: 127dB
- Power: 1,300W peak

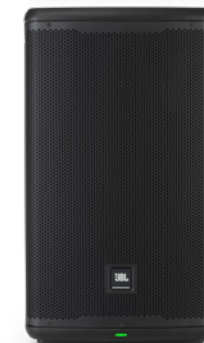

EON715

380mm (15in) TWO-WAY POWERED LOUDSPEAKER SYSTEM

The JBL EON715 15-inch loudspeaker delivers superior coverage and fidelity right out of the box, thanks to upgraded custom drivers featuring JBL 2414H compression drivers and optimized horns. These speakers are ideal for supporting any mid-sized indoor or outdoor event with loud, clear sound—and because they're stackable, they're easy to store and transport.

- Dispersion: 90°x60° HxV
- Response: 45Hz-20kHz
- Max SPL: 128dB
- Power: 1,300W peak



EON718S

457mm (18in) SELF POWERED SUBWOOFER

The JBL EON718S 18-inch powered subwoofer brings deep low-frequency extension to JBL's EON700 Series of powered loudspeakers. The EON718S produces smooth, natural bass down to 31 Hz, thanks to a newly engineered acoustic package with a completely redesigned woofer and 1,500 watts of amplification. Dial in your signature sound using the 718S' built-in parametric EQ, polarity inversion and speaker delay.

- Dispersion: omnidirectional
- Response: 31Hz-150Hz
- Max SPL: 131dB
- Power: 1,500W peak



PRX900 Series.

PROFESSIONAL POWERED PORTABLE PA LOUDSPEAKERS AND SUBWOOFERS

The JBL PRX900 Series takes professional portable PA performance to a new level with advanced acoustics, comprehensive DSP, unrivaled power performance and durability and complete BLE control via the JBL Pro Connect ecosystem. The line, which includes three powered two-way loudspeakers and two powered subwoofers, was built from the ground up to leverage JBL's most advanced acoustic innovations. New driver systems—powered by ultra-efficient 2,000-watt (peak) Class D amplifiers—deliver clarity and definition at maximum volume, with improved dispersion and smooth low-frequency extension. The PRX900 Series is a versatile solution for DJs and bands, music venues, rental houses, corporate A/V providers, or anyone who needs durable professional systems that deliver powerful, room-filling sound in any portable or installed scenario.



Dial In Your Sound with Class-Leading DSP and Control

The PRX900 Series is fully loaded with comprehensive DSP, all accessible via the JBL Pro Connect app and onboard full-color LCD. Processing includes 12-band parametric EQ and optimized system presets; onboard dbx DriveRack technology features live and fixed Automatic Feedback Suppression, soft system limiters and 180ms of speaker delay in 100-microsecond intervals for precise time-aligned systems. The JBL Pro Connect app offers BLE functionality for system control of up to 10 speakers and line integration with JBL EON ONE MK2, PRX ONE and EON700 loudspeakers. The app provides the ability to change speaker names and flash all unit LEDs for ease of speaker identification in a full ecosystem. Access full DSP functions anywhere right from the app, including app-only features like speaker snapshots and groupings.



All-New Acoustic Design

From cones to cabinets, the PRX900 Series has been built from the ground up to leverage the latest JBL acoustic innovations. Patented JBL 2408H-2 1.5in compression drivers with poly-annular diaphragms and neodymium magnets provide clear, detailed high-frequency response even at maximum volume. High-quality NTC thermistors protect transducers by reducing power sent to transducers when approaching thermal limit. Innovative new horns with updated JBL Image Control Waveguides provide optimum beamwidth and directivity. Next-generation woofers with ferrite magnets deliver smooth, natural bass response, and an FEA flared port design reduces air noise and distortion. Subwoofers feature proprietary voicecoils for improved low-frequency response. It all adds up to clean, accurate, powerful sound at any volume.

PRX908

300mm (12in) TWO-WAY FULL-RANGE MAIN SYSTEM/FLOOR MONITOR WITH WI-FI

The JBL PRX908 powered two-way 8-inch loudspeaker leverages new acoustic innovations including the patented JBL 2408H-2 1.5in compression driver with poly-annular diaphragm and neodymium magnet for clear, detailed high-frequency response. High-quality NTC thermistors protect transducers by reducing power sent to transducers when approaching thermal limit. Redesigned horns with JBL Image Control Waveguides provide optimum coverage.

- Dispersion: 105°x60° HxV
- Response: 67Hz-20kHz
- Max SPL: 126dB
- Power: 2,000W peak



PRX912

380mm (15in) TWO-WAY FULL-RANGE MAIN SYSTEM/FLOOR MONITOR WITH WI-FI

The JBL PRX912 powered two-way 12-inch loudspeaker takes advantage of JBL's iconic 2408H-2 compression driver with poly-annular diaphragm and neodymium magnet for clear, detailed high-frequency response; a next-generation woofer with ferrite magnet delivers smooth, natural bass and mids. All-new horns and Image Control Waveguides optimize dispersion and beamwidth.

- Dispersion: 90°x50° HxV
- Response: 50Hz-20kHz
- Max SPL: 132dB
- Power: 2,000W peak



PRX915

380mm (15in) SELF POWERED EXTENDED LF SUBWOOFER SYSTEM WITH WI-FI

The JBL PRX915 powered two-way 15-inch loudspeaker features new drivers with JBL 2408H-2 compression driver with poly-annular diaphragm and neodymium magnet, plus a next-generation woofer with ferrite magnet. PRX915 components are housed in a strong, lightweight enclosure that maximizes both acoustic performance and durability: Its cabinet is constructed from a rigid polypropylene/talcum blend, with a computer-modeled internal ribbing design for maximum structural integrity and minimum cabinet noise.

- Dispersion: 90°x50° HxV
- Response: 48Hz-19kHz
- Max SPL: 133dB
- Power: 2,000W peak



PRX915XLF

457mm (18in) SELF POWERED EXTENDED LF SUBWOOFER SYSTEM WITH WI-FI

The PRX915XLF 15-inch powered subwoofer, driven highly efficient 2,000W Class D power amps, produces bass with superior clarity and definition. High-quality, high-linearity inductors deliver high power efficiency and low total harmonic distortion, and low-noise, low-distortion input gain staging optimizes range and headroom for a diverse gain requirements. An 18mm birch cabinet features optimized bracing for smooth low-frequency response and improved durability.

- Dispersion: omnidirectional
- Response: 36Hz-98Hz
- Max SPL: 141dB
- Power: 2,000W peak



PRX918XLF

DUAL 380mm (15in) TWO-WAY FULL RANGE MAIN SYSTEM WITH WI-FI

The PRX918XLF 18-inch powered subwoofer is designed for advanced acoustic performance. A next-generation 918SG woofer with ferrite magnet delivers smooth, natural bass response, and an FEA flared port design reduces air noise and distortion. Its enclosure is built from 18mm birch, with strategically defined bracing that smooths low-frequency response. A Duraflex coating provides superior durability.

- Dispersion: omnidirectional
- Response: 30Hz-110Hz
- Max SPL: 134dB
- Power: 2,000W peak



SRX800 Series.

PASSIVE & SELF POWERED LARGE FORMAT LOUDSPEAKER SYSTEMS

SRX800 Passive

This line of premium portable speakers deliver the best sound quality, power handling, and workmanship in its class. Custom built, industry leading JBL transducers and enclosures give SRX800 the power and ruggedness to stand up to a variety of demanding applications. JBL Professional has made a name for itself by producing great sounding, long lasting portable PA systems. With the incorporation of tunings available for Crown amplifiers and dbx signal processors, SRX800 is an optimal choice for a fully integrated Harman Professional sound system controlled through Audio Architect. Integrating industry-leading levels of sound quality, power, control, and durability, SRX800 is a perfect all in one solution wherever high performance, comprehensive control, and pristine sound are required. Each component in the SRX800 Series was purposefully designed and thought through to deliver a perfectly tuned system that is powerful, easy to use, and rugged enough for the most demanding applications. M10 suspension points, indexed feet, and pole/tripod mounts support a wide, flexible array of configurations.

SRX800 Powered

JBL Professional has made a name for itself by producing great sounding, long lasting portable PA systems. With the introduction of the SRX800 line of powered portable PA loudspeakers, JBL has set the standard for what a fully professional powered PA system should be. SRX800 breaks new ground, bringing together JBL's premium transducers and enclosures, Crown's Proprietary Front-End DriveCore Technology, user-configurable DSP, and full HiQnet Network control compatible with a variety of platforms. Integrating industry-leading levels of sound quality, power, control, and durability, SRX800 is a perfect all in one solution wherever high performance, comprehensive control, and pristine sound are required. Each component in the SRX800 Series was purposefully designed and thought through to deliver a perfectly tuned system that is powerful, easy to use, and rugged enough for the most demanding applications.



SRX812

300MM (12in) TWO-WAY BASS REFLEX PASSIVE SYSTEM

SRX812 is a two-way full range passive portable speaker with a 12in woofer made for use as a light-duty main PA, monitor, or rear or side fill. Tunings and presets are available for Crown I Tech HD. Available in Obsidian DuraFlex™ finish.

Also available: SRX812P Self Powered System with Crown amplification.

- Dispersion: 90° x 50° HxV
- Response: 50Hz-20kHz
- Sensitivity: 94dB
- Power: 300W* 8Ω (Bi-Amp Switchable)
- Suspension: M10 x12. Dual angle pole socket



SRX815

380MM (15in) TWO-WAY BASS REFLEX PASSIVE SYSTEM

SRX815 is a two-way full range passive portable speaker with a 15in woofer made for use as a light-duty main PA, monitor, or rear or side fill. Tunings and presets are available for Crown I Tech HD. Available in Obsidian DuraFlex™ finish.

Also available: SRX815P Self Powered System with Crown amplification.

- Dispersion: 90° x 50° HxV
- Response: 50Hz-20kHz
- Sensitivity: 95dB
- Power: 800W* 8Ω (Bi-Amp Switchable)
- Suspension: M10 x12. Dual angle pole socket



SRX835

380MM (15in) THREE-WAY BASS REFLEX PASSIVE SYSTEM

SRX835 is a three-way full range speaker with a 15in woofer made for use as a medium duty main PA, or rear or side fill. Tunings and presets are available for Crown I Tech HD. Available in Obsidian DuraFlex™ finish.

Also available: SRX835P Self Powered System with Crown amplification.

- Dispersion: 60° x 40° HxV
- Response: 32Hz-20kHz
- Sensitivity: 98dB
- Power: 800W* 8Ω
- Suspension: M10 x12. Pole socket



SRX818S

457MM (18in) PASSIVE SUBWOOFER SYSTEM

SRX818S is a single 18in subwoofer for concert, touring, or installed use. Featuring a standard M20 pole cup for use with top boxes, indexing feet for stacking in both the standard and cardioid position, and a 136dB max SPL, the SRX818S is an ideal solution for musicians, bands, and DJs, concert use, public speaking, or in performance venues, corporate spaces, educational facilities or houses of worship. Tunings and presets are available for Crown I Tech HD. Available in Obsidian DuraFlex™ finish.

Also available: SRX812SP Self Powered System with Crown amplification.

- Response: 28Hz-150Hz
- Sensitivity: 95dB
- Power: 600W* 8Ω
- Suspension: M20 Pole socket



SRX828S

457MM (18in) DUAL SUBWOOFER

SRX828S is a dual 18in subwoofer for concert, touring, or installed use. Featuring a wide stance for splaying top boxes, indexing feet for stacking in both the standard and cardioid position, and a 141dB max SPL, the SRX828S is an ideal solution for musicians, bands, and DJs, concert use, public speaking, or in performance venues, corporate spaces, educational facilities or houses of worship. Tunings and presets are available for Crown I Tech HD. Available in Obsidian DuraFlex™ finish.

Also available: SRX828P Self Powered System with Crown amplification.

- Response: 30Hz-150Hz
- Sensitivity: 98dB
- Power: 1200W* 4Ω
- Suspension: M20 Pole socket



*2 Hour IEC with 6dB Crest.

EON ONE Compact.

ALL-IN-ONE BATTERY-POWERED PORTABLE PA WITH PROFESSIONAL-GRADE MIXER

The days of sacrificing sound system power and performance for portability are over. The JBL EON ONE Compact packs a professional speaker, a full-featured, 4-channel mixer and Bluetooth control into our most compact battery-powered PA, weighing in at just 17.6 pounds. Sound your best in seconds with premium Lexicon and dbx-inspired effects and presets that you can customize right on your phone or tablet using the JBL EON ONE Compact Control app—no engineer needed. Presenters, fitness instructors and emcees will appreciate EON ONE Compact's ducking feature, which lowers background music volume when speech input is detected. Peer-to-peer Bluetooth lets you broadcast music playback. And with EON ONE Compact's tool-free, swappable 12-hour battery, you'll keep the party going long after the sun goes down.

- 112 dB output the highest volume in its class
- Best in class low - down to 37Hz
- Ultralight unit weighs just 17.6 pounds (8 kg)
- Effects including EQ, reverb, chorus and delay
- Built-in 4-channel mixer
- Bluetooth connectivity



EON ONE MK2.

ALL-IN-ONE RECHARGEABLE COLUMN PA WITH BUILT-IN MIXER AND DSP

The JBL EON ONE MK2 packs a class-leading acoustic package, 5-channel digital mixer, dbx and Lexicon DSP, Bluetooth functions and universal app control into a lightweight, portable package. The EON ONE MK2 delivers the fidelity JBL is legendary for, combining a geometrically optimized, C-shaped 8-tweeter array with a 10in woofer to deliver class-leading clarity and coverage down to 37 Hz, with wide dispersion and a maximum output of 123 dB. The EON ONE MK2 is engineered for versatility and ease of use: Dial up your sound in an instant, thanks to a full suite of pro-grade Lexicon and dbx effects and presets. Variable Power Performance automatically optimizes power performance for AC or battery operation. Bluetooth audio streaming and six-hour battery operation round out the advantages of this all-in-one system.

- C-shaped array of (8)2in tweeters
- Natural, smooth low end, down to 37 Hz
- Variable Power Performance
- Built-in 1,500-watt (peak) amplifier
- Frequency response: 37 Hz–20 kHz
- Easily swappable 6-hour battery



USB POWER CABLE

Adding even greater freedom and flexibility to your live sound setup, the JBL EON ONE Compact USB Power Cable allows you to easily power an AKG wireless system or a DigiTech-DOD guitar pedal directly from your JBL EON ONE Compact battery-powered portable P.A. With a USB A connection that plugs into your speaker and a 5.5mm power terminal that connects to an AKG DMS or WMS system or a wide range of DigiTech-DOD pedals, the cable lets you use your EON ONE Compact's rechargeable battery to power select external devices.



CLASS-LEADING CONNECTIVITY

The EON ONE Compact offers more inputs than any system in its class. Two XLR/TRS combo jacks, one 1/4-inch hi-Z guitar input and one 1/8-inch aux input connect microphones, line-level instruments and audio playback sources; phantom power supports condenser microphones, and pro-grade preamps deliver full, rich sound from any microphone. Plus, a 1/4-inch passthrough lets you expand your system with additional EON ONE Compact units. Use the built-in headphone jack to rehearse privately or dial in presets before performances. Two high-power USB 3.0 ports allow high-speed charging of tablets, phones and select DJ devices.



LONG-LASTING BATTERY LIFE

Play more sets or teach more classes, confident in EON ONE Compact's 12-hour battery life. Swap out batteries in seconds—no tools necessary—and quick-charge batteries in just 2.5 hours. You can even charge while the system is in use.

SOUND YOUR BEST WITH PRO FX

EON ONE MK2 features a full suite of professional DSP, including Lexicon reverb, chorus and delay and dbx DriveRack Inside technology, including AFS (Automatic Feedback Suppression) and 8-band EQ. Presenters, fitness instructors and emcees will appreciate the Soundcraft Easy Ducking feature, which lowers background music volume anytime you speak. DSP presets and onboard hardware EQ with 3 fixed knobs make it even easier to hone your signature sound, fast.



EON ONE MK2 DUAL BATTERY CHARGER

The JBL EON ONE MK2 dual battery charger is the perfect accessory to accompany the EON ONE MK2 for those long gigs that require extended performance power to take you late into the evening or early into the morning.

POWER THAT WORKS SMARTER, NOT HARDER

EON ONE MK2's robust 1,500-watt (peak) amplifier ensures clean, distortion-free sound at any volume level. Variable Power Performance technology automatically optimizes performance for either AC or battery power, providing 4 dB extra headroom when connected to AC power. You'll be heard loud and clear, no matter where you play.

TOTAL CONTROL, AT YOUR FINGERTIPS

EON ONE MK2 can be controlled by the universal JBL Pro Connect app, which provides remote access to every function and preset, right from your phone or tablet; JBL's ActiveSync technology ensures the app and system LCD are always in perfect sync. The EON ONE MK2 offers Bluetooth 5.0 audio streaming to one device, with control of up to 10 units.



12-hour Battery



Bluetooth Connectivity



Best-in-Class Output/LF Ext.



One-Touch Ducking



EQ, Reverb, Delay, Chorus



7 Year Warranty



Built-in Mixer



App Control





PRX ONE.

ALL-IN-ONE POWERED COLUMN PA WITH MIXER AND DSP

The JBL PRX ONE all-in-one powered column PA features an acoustically optimized column array featuring a 7-channel digital mixer, a full suite of professional DSP, class-leading audio connectivity, Bluetooth functionality and JBL Pro Connect universal app control. PRX ONE delivers a stunning 130db max SPL, with consistent front-to-back throw, thanks to its custom-engineered 12-tweeter column array featuring JBL AIM acoustic technology, 12-inch bass-reflex woofer and built-in 2,000-watt (peak) amplifier. Work faster and easier with an intuitive Soundcraft-designed dual-mode digital mixer that can be set to general mix functions or channel-strip control, all controllable via app or a built-in color LCD.

- Vertical array of (12) 2.5-inch drivers
- Custom-designed high-frequency drivers
- JBL A.I.M. (Array Innumbration Mechanics)
- Wide, 130° (H) x 30° (V) dispersion pattern
- Extended low-end response to 35 Hz
- 2,000-watt (peak), fully bridged Class D amplifier

EVERYTHING YOU NEED TO DIAL IN YOUR SIGNATURE SOUND

Who wants to lug cumbersome outboard effects to gigs? Sculpt your sound right inside PRX ONE with a full suite of iconic dbx and Lexicon audio effects, including reverb, delay, chorus, echo, compression, limiting and gating. Presenters, teachers and fitness instructors will always be heard loud and clear when they rely on PRX ONE's built-in ducking feature, which lowers background music when speech is detected. Presets let you save and recall go-to settings. Four console-quality microphone preamps maintain full bandwidth, even at maximum gain. It all adds up to clean, clear, studio-quality sound, no matter how loud you go.



EASY MOUNTING BRACKET KIT

PRX ONE can be used in both portable applications and fixed installations; installers, presenters and houses of worship will appreciate the ability to detach and mount the PRX ONE array separately from the subwoofer, using an optional mounting accessory.

PRISTINE POWER AT ANY VOLUME

Go ahead, crank it up with confidence, thanks to ultra-efficient amplification that ensures you'll be heard loud and clear at any volume level. PRX ONE's 2,000-watt Class D amplifier with power factor correction delivers clean, stable power through various voltages, ensuring longevity of components and reliable operation anywhere. High-quality, high-linearity inductors improve efficiency and minimize total harmonic distortion. And, because the amp is fully bridged, you'll truly tap its full power potential, with plenty of headroom to handle any scenario.

AN ALL-IN-ONE CONTROL ECOSYSTEM

Get hands-on anywhere with the JBL Pro Connect app, which offers control over every PRX ONE feature from mixing to DSP to Bluetooth functions. Adjust levels from anywhere in the room. Because the app and the mixer are always in sync, you'll never have to guess where your levels are. Plus, get access to Plus get access to app-only features like speaker grouping, delay tap tempo, and whole speaker snapshots.



STUDIO MONITORS



3 Series MKII.

POWERED STUDIO MONITORS

The 3 Series Powered Studio Monitors are the first to incorporate JBL's groundbreaking Image Control Waveguide from our flagship M2 Master Reference Monitors. Unprecedented detail, imaging and depth clearly reveal micro-dynamics in reverb tails, subtleties of mic placement, and a tangible sense of a centre channel speaker. A broad, room-friendly sweet spot ensures equal dimension and transparency for everyone in the room. With legendary JBL transducers and custom-designed power amplifiers, the 3 Series will boost the image in your studio. With three different models to choose from, there's a 3 Series monitor to fit your studio and budget.

305P MKII

127mm (5IN) POWERED TWO-WAY STUDIO MONITOR

The 127mm (5in) 305P MkII offers a remarkably full sound in an enclosure small enough to fit in the tightest workspace. Available in Matte Black pvc finish.

- Dispersion: 120° x 90° HxV
- Response: 43Hz-24kHz
- Power: 41-watts x2, Class D, Bi-Amp



306P MKII

165mm (6.5IN) POWERED TWO-WAY STUDIO MONITOR

The 165mm (6.5in) 306P MkII is perfect if you need even more volume and bass response while still maintaining a compact footprint. Available in Matte Black pvc finish.

- Dispersion: 120° x 90° HxV
- Response: 39Hz-24kHz
- Power: 56-watts x2, Class D, Bi-Amp



308P MKII

200mm (8IN) POWERED TWO-WAY STUDIO MONITOR

The 200mm (8in) 308P MkII is the largest and most powerful of the three models in the series, offering impressive low end, high output and excellent dynamic range. Available in Matte Black pvc finish.

- Dispersion: 120° x 90° HxV
- Response: 37Hz-24kHz
- Power: 56-watts x2, Class D, Bi-Amp



LSR310S

254mm (10IN) POWERED STUDIO SUBWOOFER WITH XLF

Extend your system LF all the way down! The LSR310S subwoofer incorporates JBL's patented Slip Stream™ Port working in concert with a custom 10in down-firing driver and a 200 Watt amplifier to add deep, powerful bass to any studio monitor system. A JBL first, the XLF Extended Low Frequency setting lets you hear your tracks with the augmented bass tuning used in today's dance clubs. Available in Matte Black pvc finish.

- Response: 27Hz-80Hz
- Power: 200-watts, Class D



7 Series. MASTER REFERENCE MONITORS

The JBL 7 Series provides a powerful and flexible monitoring solution for music, post and broadcast production. Now available in four models—the install 705i and 708i and the powered 705P and 708P—these monitors deliver exceptional output, stunning detail, an expansive soundstage and impressive accuracy. 7 Series speakers achieve this outstanding performance by leveraging patent-pending driver technologies and the renowned JBL Image Control Waveguide. All models integrate with the Intonato 24 Monitor Management Tuning System, which provides intuitive remote control and calibration. 7 Series monitors are equally at home in stereo, surround, and immersive-audio production rooms.



705i 127mm (5IN) MASTER REFERENCE MONITOR

The 705i is an essential next generation multi-channel monitor for post rooms, broadcast facilities and trucks. Leveraging patented technologies developed for our flagship M2 Master Reference Monitor, the 705i delivers detailed imaging, extended frequency response and remarkable output from compact enclosures. Centrally amplified and tuned, and easily installed, the 705i is the heart of an elegant, scalable system for broadcast and post facilities.

- Next Generation Systems for Post and Broadcast Production
- Next Generation Driver Technology
- Patent Pending Image Control Waveguide
- Compact, Install Friendly Enclosures



708i 203mm (8IN) MASTER REFERENCE MONITOR

Leveraging patented technologies developed for our flagship M2 Master Reference Monitor, the 708i delivers detailed imaging, extended frequency response and remarkable output from compact enclosures. Centrally amplified and tuned, and easily installed, the 708i Studio Monitor is the heart of an elegant, scalable system for broadcast and post facilities working in immersive audio formats.

- Next Generation Systems for Post and Broadcast Production
- Next Generation Driver Technology
- Patent Pending Image Control Waveguide
- Compact, Install Friendly



705P 127mm (5IN) BI-AMPLIFIED MASTER REFERENCE MONITOR

The JBL 705P is a self-powered reference monitor for critical music recording, film post and broadcast production applications. It leverages the same patent-pending driver technologies and JBL's renowned Image Control Waveguide found in the 708P and the flagship M2, but with a smaller footprint. Despite its compact size, JBL 705P delivers an eye-opening level of output, well beyond that of existing, comparably-sized studio monitors, for greater dynamic range and greater working distances.

- Next-generation JBL driver technology
- Image Control Waveguide
- Dual amplification system
- Room EQ and delay controls
- Compact enclosure



708P 203mm (8IN) BI-AMPLIFIED MASTER REFERENCE MONITOR

JBL 708P is a self-powered reference monitor for critical music recording, film post and broadcast production applications. The 708P leverages new patent-pending driver technologies and JBL's renowned Image Control Waveguide to deliver extraordinary output, stunning detail, an expansive soundstage, and greater accuracy in a broad range of rooms. 708P delivers several times the output of other comparably-sized studio monitors, providing significantly greater dynamic range and greater working distances.

- Next-generation JBL driver technology
- Image Control Waveguide
- Dual amplification system
- Room EQ and delay controls
- Compact enclosure



CINEMA SPEAKERS



SFC Yonghua Cinema City, China

200 Series. TWO-WAY SCREENARRAY® LOUDSPEAKERS

The 200 Series combines JBL's latest technological advances with a compact footprint and accessible price point, making it easy to upgrade the sonic experience in your small or mid-sized cinema. Featuring patent-pending Dual Dissimilar Arraying and Acoustic Aperture Technology, the JBL 200 series provides remarkably uniform coverage and smooth, accurate sound reproduction for every member of your audience. Models range from 12-14in thin, perfect for small and medium multiplexes with space constraints. And since the 200 Series uses the same driver technology trusted by top movie studios around the world, your audience will enjoy a more captivating, authentic experience from every seat in the house—just like the creators intended.

C211 TWO-WAY SCREENARRAY CINEMA LOUDSPEAKER

The C211 has a depth of 12in, making it perfect for small cinemas with space constraints. The C211 uses the same high frequency driver technology that is found in the 7 Series master reference studio monitors, which is trusted by top movie studios around the world, your audience will enjoy a more captivating, authentic experience from every seat in the house—just like the creators intended. With a maximum throw of 16 m (52'), the C211 is designed for a small to medium cinema as well as VIP viewing rooms.

- Next-generation two-way ScreenArray®
- 12in footprint
- Advanced passive crossover network
- 2409H uses same HF driver



C221 TWO-WAY SCREENARRAY CINEMA LOUDSPEAKER

Featuring patent-pending Dual Dissimilar Arraying and Acoustic Aperture Technology, the C221 provides remarkably uniform coverage and smooth, accurate sound reproduction for every member of your audience. The C221 has a depth of 12in, making it perfect for small and medium multiplexes with space constraints.

- Next-generation two-way ScreenArray®
- 12in footprint
- Advanced passive crossover network
- 2409H uses same HF driver

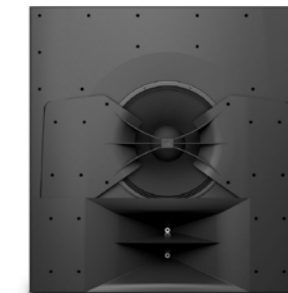

C222 TWO-WAY SCREENARRAY CINEMA LOUDSPEAKER

The C222 is ideal for small and medium multiplexes, studios and dubbing stages with space constraints. And since the C222 uses the same driver technology trusted by top movie studios around the world, your audience will enjoy a more captivating, authentic experience from every seat in the house..

- Next-generation two-way ScreenArray®
- Dual Dissimilar Arraying Technology
- Acoustic Aperture Technology
- 12in footprint

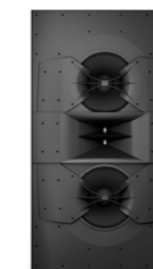

C222HP TWO-WAY HIGH PERFORMANCE SCREENARRAY CINEMA LOUDSPEAKER

The C222HP is perfect for small and medium multiplexes, studios and dubbing stages with space constraints. And since the C222HP uses the same driver technology trusted by top movie studios around the world, your audience will enjoy a more captivating, authentic experience from every seat in the house—just like the creators intended.

- Next-generation two-way ScreenArray®
- Dual Dissimilar Arraying Technology
- Acoustic Aperture Technology
- 14in footprint

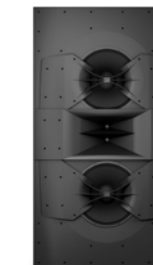

ScreenArray Systems (3-Way).

THREE-WAY SCREENARRAY® LOUDSPEAKERS

The 200 Series combines JBL's latest technological advances with a compact footprint and accessible price point, making it easy to upgrade the sonic experience in your small or mid-sized cinema. Featuring patent-pending Dual Dissimilar Arraying and Acoustic Aperture Technology, the JBL 200 series provides remarkably uniform coverage and smooth, accurate sound reproduction for every member of your audience. Models range from 12-14in thin, perfect for small and medium multiplexes with space constraints. And since the 200 Series uses the same driver technology trusted by top movie studios around the world, your audience will enjoy a more captivating, authentic experience from every seat in the house—just like the creators intended.

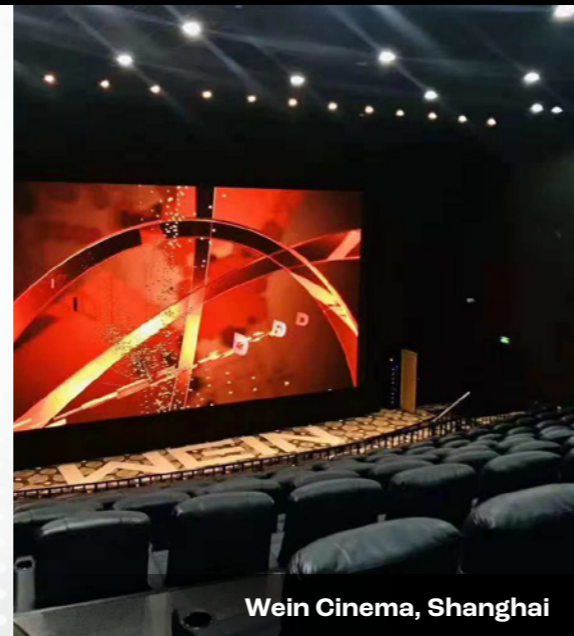

Wein Cinema, Shanghai

High Power Screen Arrays.

FOUR-WAY HIGH POWER SCREENARRAY® LOUDSPEAKERS

The JBL 4-Way High Power ScreenArray Loudspeakers are available in two systems feature a 150 Watt, 4in titanium diaphragm high-frequency compression driver on JBL's patented Optimized Aperture waveguide with Screen Spreading Compensation™. The 5742 system features a quad mid-range array of four 8in Differential Drive® cone mid-range drivers providing 1400 Watts of smooth coverage, coupled with a dual 18in SVG™ Super Vented Gap low-frequency section, providing 1600 Watts of high power output with minimum distortion. The 5732 dual-mid-range version using a dual 15in, 1200 Watt, low-frequency section is also available.



Filmpalast Kassel, Germany

3732 / 3732-T

THREE-WAY BIAMPLIFIED OR TRIAMPLIFIED(T) SCREENARRAYLOUDSPEAKER SYSTEM

Today's premier cinemas require perfect coverage in every seat of the auditorium, wide dynamic range and extended bandwidth, as well as inaudible levels of distortion. Digital soundtracks, especially those associated with the latest digital cinema requirements, require sound systems that can accurately reproduce the sound exactly as recorded. The 3732/3732-T ScreenArray Cinema Loudspeaker System features true three-way design enhanced by advanced engineering. JBL's latest technical innovations are integrated into a system design that provides superior coverage, maximum power handling and uniform acoustic power output, along with extremely low distortion. The ScreenArray design provides ideal power response and directivity control with seamless transitions between acoustic sections.

- Three-way ScreenArray™
- Triamplified (T) or Bi-amplified operation
- Second Generation Optimized Aperture Waveguide
- SSC™ Screen Spreading Compensation
- Focused Coverage Technology™



5732

3-WAY HIGH POWER SCREENARRAY LOUDSPEAKERS

Today's premier cinemas require perfect coverage in every seat of the auditorium, wide dynamic range and extended bandwidth, as well as inaudible levels of distortion. Digital soundtracks require sound systems for premier auditoriums that can accurately reproduce the sound exactly as recorded. Designed for high power critical sound reproduction in premier cinemas, studio production and post production applications, the 5732 high power ScreenArray features true three-way design, enhanced by advanced engineering. JBL's latest technical innovations are integrated into a system design that provides superior coverage, maximum power handling and uniform acoustic power output, along with extremely low distortion. The ScreenArray design provides ideal power response and directivity control with seamless transitions between acoustic sections.

- Three-way ScreenArray® design
- 700 watt midrange
- Large format 4in neodymium
- 1200 W low-frequency section
- JBL Patented SSC™ Screen spreading Compensation
- Focused Coverage Technology



4732 / 4732-T

THREE-WAY BIAMPLIFIED OR TRIAMPLIFIED(T) SCREENARRAYLOUDSPEAKER SYSTEM

Digital soundtracks, especially those associated with the latest digital cinema requirements, require sound systems that can accurately reproduce the sound exactly as recorded. The 4732/4732-T ScreenArray Cinema Loudspeaker System features true three-way design enhanced by advanced engineering. JBL's latest technical innovations are integrated into a system design that provides superior coverage, maximum power handling and uniform acoustic power output, along with extremely low distortion. The ScreenArray design provides ideal power response and directivity control with seamless transitions between acoustic sections.

- Three-way ScreenArray™
- Triamplified (T) or Bi-amplified operation
- Second Generation Optimized Aperture Waveguide
- SSC™ Screen Spreading Compensation
- Focused Coverage Technology™



5742

4-WAY HIGH POWER SCREENARRAY LOUDSPEAKERS

Large format and 3D cinemas require perfect coverage in every seat of the auditorium, wide dynamic range and extended bandwidth, as well as inaudible levels of distortion. Digital soundtracks require sound systems for premier auditoriums that can accurately reproduce the sound exactly as recorded. Designed for high power critical sound reproduction in large format cinemas, studio production and post production applications, the 5742 high power ScreenArray features true four-way design enhanced by advanced engineering. JBL's latest technical innovations are integrated into a system design that provides superior coverage, maximum power handling, and uniform acoustic power output, along with extremely low distortion. The ScreenArray design provides ideal power response and directivity control with seamless transitions between acoustic sections.

- Four-way ScreenArray® design
- 1400 watt midrange
- Large format 4in neodymium
- 1600 W low-frequency section
- JBL Patented SSC™ Screen spreading Compensation
- Focused Coverage Technology



9300 Series.

CINEMA SURROUND LOUDSPEAKERS

Let your audience hear the truth in every cinematic experience with the JBL 9300 Surround Series. The 9300/9310 Cinema Surround Loudspeakers feature JBL Image Control Technology and asymmetric pattern control guided by exclusive Wave Shaping Vanes that distribute a sculpted, acoustic wave-front. The 9350 uses three patent pending technologies (Dual Dissimilar Arraying, Acoustic Divider Waveguide, and Bi-pole Wall Decoupling) to be the ideal choice for gap, rear or side surround speakers and provide a much larger sweet spot than traditional loud speaker technologies. Elevate your next cinema sound project with the JBL 9300 Surround Series.

9300
SURROUND SERIES
9300 - 9310 - 9320 - 9350



Humax Cinema, Japan

9300

CINEMA SURROUND LOUDSPEAKER 2-WAY PASSIVE 1IN HF, 10IN WOOFER (2IN VC)

The 9300 Cinema Surround offers high 250 Watt power handling capability, high sensitivity, and extended base response in a groundbreaking design. The two-way 9300 features new transducer technologies, waveguide and horn designs developed specifically to produce studio quality performance with pattern control tailored to modern theatre geometries.

- 250 Watt Power handling capability
- Wave Shaping Vane
- JBL Image Control Technology
- Lightweight, Rigid molded enclosure
- Uniform asymmetric 60 degree vertical coverage and 110 degree horizontal coverage



9310

HIGH POWER CINEMA SURROUND LOUDSPEAKER 2-WAY PASSIVE 1IN HF, 10IN WOOFER (2IN VC)

The 9310 Cinema Surround offers high 350 Watt power handling capability, high sensitivity, and extended base response in a groundbreaking design. The two-way 9310 features new transducer technologies, waveguide and horn designs developed specifically to produce studio quality performance with pattern control tailored to modern theatre geometries.

- 350 Watt Power handling capability
- Wave Shaping Vane
- JBL Image Control Technology
- Lightweight, Rigid molded enclosure
- Uniform asymmetric 60 degree vertical coverage and 110 degree horizontal coverage



9320

12IN HIGH POWER CINEMA SURROUND FOR MULTI CHANNEL APPLICATIONS

The 9320 Cinema Surround Speaker offers very high power handling, high sensitivity, and extended bass response. The two-way 9320's performance features position it as the ideal high power surround for multi-channel surround applications.

- 35 Hz to 20 kHz Frequency Range
- High Sensitivity, 98 dB SPL, 1 w, 1 m (3.3 ft)
- High Power Handling Capability
- 120° x 60° Coverage
- Multi-ply birch enclosure



9350

127mm (5IN) MASTER REFERENCE MONITOR

The 9350 packs a sonic punch, and delivers extraordinary coverage through its advanced engineering, including three patent-pending technologies. Each loudspeaker generates a sculpted side or rear pattern, adjusted with the flick of a switch. With a passive crossover network, waveguide technologies, and line array techniques, coverage can be adjusted to fit a theatre's unique environment.

- 35 Hz to 20 kHz Frequency Range
- High Sensitivity, 98 dB SPL, 1 w, 1 m (3.3 ft)
- High Power Handling Capability
- 120° x 60° Coverage
- Multi-ply birch enclosure

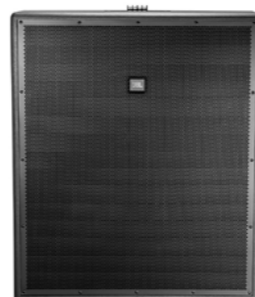

JBL Sculpted Surround

Providing a flawless surround sound experience to every seat in your cinema

After analyzing the dispersion of sound in a stadium-seating environment, JBL designed the 9300 Cinema Surround Loudspeakers with specific directivity for that geometry. The surrounds were designed with a 15-degree tilt built into the back panel and mounting system. By angling the side surrounds 15 degrees toward the screen, the hotspot and rearward bias have been eliminated while considerably broadening the sound coverage in the theater.

This arrangement is called the JBL Sculpted Surround System because it shapes the sound radiation pattern of the room into a pattern that compliments the screen channels. For easy implementation of the Sculpted Surround System, the 9300 and 9310 are equipped with a mounting mechanism so theater installers can easily position them with the 15-degree tilt.

Besides expanding the audience sweet spot, another major benefit of tilting the surrounds is that the coverage improvements reduce the number of loudspeakers required in the each theater. Because of the speakers' specific directivity and new positioning, each covers a slightly larger area, and can, therefore, be incrementally separated along the wall.

To improve the rear channel issue, JBL developed the JBL 9350, a configurable pattern speaker with three patent-pending technologies. It's the first surround loudspeaker to offer rear coverage directivity as one of its options. When you set them to be positioned in the rear, you only need a single stereo pair for small and medium rooms. When using them as left and right rear mains, there's no need to have additional speakers in the back of the theater.

Traditional 5.1/7.1 Surround Sound

Typical surround loudspeakers that are not adjusted for the inclined rake in theaters can create a buildup and uneven distribution of surround information. As a result, moviegoers may have vastly different surround sound experiences in the same room.

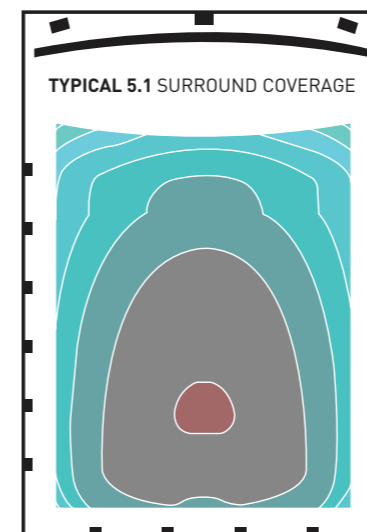

Sculpted Surround (5.1/7.1 System)

A sculpted surround system accommodates stadium seating in order to evenly deploy sound throughout the room. Designed specifically for 5.1 and 7.1 surround systems in cinemas, sculpted surround ensures uniformity so that moviegoers experience sound the way moviemakers intended.

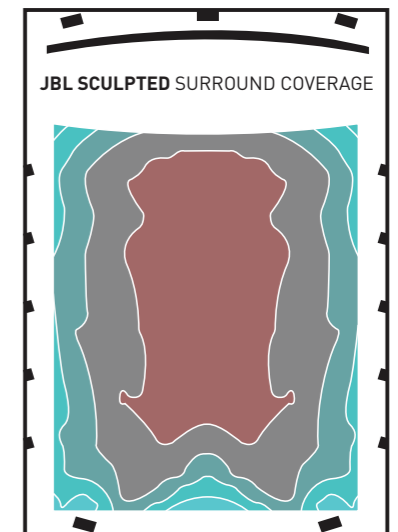

Cinema Subwoofers.

PROFESSIONAL CINEMA SUBWOOFERS

No other manufacturer provides a wider, more cost-effective range of solutions to take on the demands of modern cinema sound reproduction than JBL Professional. With one of the longest track records in the industry (James B. Lansing Sound, Incorporated manufactured some of the world's first true high-fidelity loudspeakers for cinema sound systems) and JBL's legendary reputation for quality, reliability, and innovation, it's easy to see why today more than three quarters of all cinema loudspeakers sold worldwide come from JBL Professional.



Sai Teerth Devotional Theme Park, Mumbai

CINEMA AMPLIFIERS

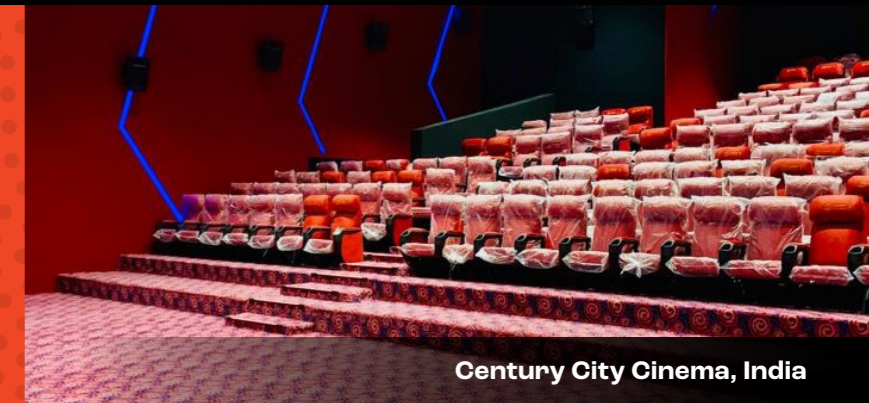

Century City Cinema, India

4642A

4642A DUAL 460mm (18 IN.) SUBWOOFER SYSTEM

The JBL Model 4642A is a high quality subwoofer system, featuring an advanced technology 460 mm (18 in), low frequency transducers mounted in a direct radiator, bass-reflex enclosure for smooth response to the lowest audible frequencies. The 4642A is ideal for low-frequency augmentation of either analog or digital soundtracks in motion picture theaters and for general sound reinforcement applications.

- 1200 Watts Continuous
- Usable response to 22 Hz
- High Power Handling Capability
- 2241H VGCTM Vented Gap Cooled Drivers
- Approved by Lucasfilm, Ltd. for THX® installations



5628

ULTRA LONG EXCURSION VERY HIGH POWER DUAL 18IN CINEMA SUBWOOFER

The 5628 is a high power, lightweight front-loaded vented subwoofer enclosure housing two of JBL's exclusive 2269H Ultra Long Excursion 18in Differential Drive® woofers. This woofer features neodymium magnet, dual voice coils and dual gaps, JBL's exclusive Vented Gap Cooling™ and ultra robust composite cone for high excursion and extra long life. Woofer is capable of a peak-to-peak maximum excursion of 89 mm (3.5in).

- 2 x 2269H 18in Differential Drive®
- 4000 watts continuous pink noise
- Ultra Long Excursion
- Large vent area for high output with low distortion



4281F

PROFESSIONAL HIGH-POWER CINEMA SUBWOOFER

The 1,600-watt 4281F delivers room-shaking low end for a variety of cinema configurations, including Dolby Atmos and DTS:X installations. The 4281F works seamlessly with the entire JBL Cinema Series, which includes two 3-way screen speakers and a surround speaker. Combine Cinema Series speakers with the JBL CPi2000 cinema processor and Crown XLC Series amps to build a fully integrated JBL cinema sound solution.

- 1600 Watts Continuous power
- 139 dB peak SPL
- Built-in rigging points
- Binding-post input connectors
- Frequency response: 30 Hz–500 Hz



3181F

PROFESSIONAL HIGH-POWER CINEMA SUBWOOFER

The 650-watt 3181F delivers room-shaking low end for a variety of cinema configurations, including Dolby Atmos and DTS:X installations. The 3181F works seamlessly with the entire JBL Cinema Series, which includes two 3-way screen speakers and a surround speaker. Combine Cinema Series speakers with the JBL CPi2000 cinema processor and Crown XLC Series amps to build a fully integrated JBL cinema sound solution.

- 650 Watts Continuous power
- 132 dB peak SPL
- Built-in rigging points
- Binding-post input connectors
- Frequency response: 30 Hz–500 Hz



DSI 2.0 SERIES AMPLIFIERS

MORE POWER. MORE RELIABILITY.

The DSI 2.0 amplifier family, JBL's first line of dedicated cinema amplifiers, builds on Crown DSI Digital Screen Array amplifier technology, integrating best-in-class DSP from Crown's flagship CDi DriveCore series to deliver potent, cost-effective amplification for JBL's entire range of cinema loudspeakers. Choose from three power configurations, available in analog and analog-plus-digital "D" versions featuring Dante/AES67 connectivity.

Deploy systems faster and easier while streamlining hardware needs: DSI 2.0 amplifiers are designed to meet power requirements of JBL cinema speakers, for a single JBL cinema solution. D-models interface with Dolby Atmos directly, without the need for additional processing hardware. JBL Cinema Speaker presets simplify configuration, optimize playback audio and protect against equipment damage. All DSI 2.0 amps feature SNMP connectivity for networked audio distribution, immersive installations and direct interfacing with third-party theater-management and cinema-control systems.

RATED POWER SPECIFICATIONS			
	SA4 & SA4-D	MA4 & MA4-D	LA4 & LA4-D
8Ω	350W x 4	750W x 4	1,300W x 4
4Ω	700W x 4	1,400W x 4	2,200W x 4
2Ω	1,050W x 4	2,100W x 4	1,200W x 4
8Ω (Bridged)	1,300W x 2	2,600W x 2	4,000W x 2
4Ω (Bridged)	2,200W x 2	4,200W x 2	2,300W x 2

- An intuitive front-panel LCD and encoder interface let you configure amplifier settings at the push of a button.
- Ultra-quiet operation: 51dBA maximum fan noise
- All models are standard 19-inch (482mm) 2RU rackmount units.
- Weight: 23.2 pounds (10.5 kg)
- Frequency response: 20 Hz–20 kHz
- Power supply: 100–220V +/- 10%, 50/60 Hz
- Power connector: Standard IEC type, 320 inlet for detachable connector, 100–240V



XLC SERIES AMPLIFIERS

SMALL THEATER, BIG SOUND

From staying on top of your concession inventory to scheduling personnel to payroll management, keeping your small theater running smoothly can keep you running. So you need to select an audio system you know you can count on to deliver the best cinematic sound for each and every movie. Crown's affordable new XLC Series amplifiers, paired with JBL® cinema sound products, makes your choice simple and easy. Both the XLC2500 and XLC2800 amps include Crown's DriveCore™ Technology, which replaces up to 500 parts with one small chip. This significantly reduces the part count, increasing reliability and energy efficiency while maintaining brilliant performance.

RATED POWER SPECIFICATIONS			
	XLC2500	XLC2800	XLC21300
8Ω	300W x 2	400W x 2	1,000W x 2
4Ω	500W x 2	775W x 2	1,300W x 2
2Ω	775W x 2	1,200W x 2	
8Ω (Bridged)	1,000W x 2	1,550W x 2	2,700W x1
4Ω (Bridged)	1,550W x 2	2,400W x 2	

- Power for 2-ohm, 4-ohm and 8-ohm outputs, supporting stereo and bridge outputs
- Support parallel connection of cinema surround speaker Indicators provide accurate diagnostics: Power, Signal, Clip and Fault
- Volume control on rear panel of amplifiers
- High performance, light weight
- Minimal front panel control; block connectors and controls on back of amplifiers

CINEMA PROCESSOR



Wein Cinema, Shanghai

JBL COMMERCIAL SERIES



CPI2000 CINEMA PROCESSOR



Place Your Audience In The Middle Of The Action

Deliver a theatre sound experience that's as enveloping as the excitement onscreen. Professional features like DSP, EQ, crossover, loudspeaker management, JBL cinema speaker presets and customizable software functions let you fine-tune each system with total precision, while a user-friendly LCD screen interface and front-panel volume control let theatre staff manage their systems with ease. It's all part of creating an unforgettable movie experience that will keep audiences coming back and keep your cinema customers happy.

Features

Easy to Use

Features like GUI Software and one volume knob makes for simple setup and operation

Built-in Crossover

Up to 7.1 channels with support for passive, bi-amp or tri-amp crossover configurations

Supports TMS Communication

Theater Management System communication provides convenient remote control and saves on system operation cost

JBL Cinema Speaker Presets

Reduces tuning time while optimizing sound quality

Large LCD Display

Provides system status at a glance

USB Connector

For preset file import and export

Highlights

A Complete HARMAN 7.1 Cinema Solution

When combined with Crown cinema amplifiers and JBL cinema speakers, the CPI2000 completes the HARMAN roster to deliver next-generation performance and value to 7.1 cinemas around the world.

Better Sound With Less Effort

With speaker presets for a variety of JBL cinema speakers and a 1/3 octave GEQ for room tuning via an RTA microphone (sold separately) and GUI software, the CPI2000 does much of the heavy lifting, making system tuning a breeze.

Easy Operation

The GUI software and integrated tuning system make it easy to configure and optimize the sound system. Once installed, the large front-panel LCD display and controls make it easy for staff to monitor the system, select sources and adjust volume.

Over-Network System Monitoring & Redundancy

Monitor status of speakers and amps via the front-panel LCD display, GUI software or TMS. And if a fault does occur, the built-in fault detection system sends a notification and automatically re-routes audio to the Redundant Output.

JBL® Commercial Series, a dynamic blend of the best HARMAN brands, knows for any business, the audio system is essential to keeping your customers informed and captivated.

Leveraging the expertise honed by years of precision sound reproduction and technical innovation by JBL and other HARMAN brands, JBL Commercial crafts top-quality components to offer you high-performance yet affordable sound systems.

By providing a premium listening experience for decades in everything from large arenas to private homes, JBL is one of the most recognised and respected brands in the audio industry. Capitalising on JBL's legendary achievements in audio engineering and technology enables JBL Commercial to set new standards in sound.

That means you'll find that our integrated array of mixer-amplifiers, amps, mixers, speakers, microphones, and wall controllers delivers precise, reliable sound in any commercial application, from soothing spas to bustling bars.

As your single-brand source, JBL Commercial Series simplifies the search for high-performance, comprehensive and versatile audio solutions for your business.

Visit www.jblcommercialproducts.com for more information.



Amplifiers.

COMMERCIAL SERIES AMPLIFIERS



CSA140Z/180Z/1120Z

1 X 40/80/120W AUDIO AMPLIFIERS

DRIVECORE™ 

CSA240Z/280Z/2120Z

2 X 40/80/120W AUDIO AMPLIFIERS

By combining years of innovation, invention and insight from HARMAN brands, JBL® Commercial Series Amplifiers (CSA) go well beyond the expected in generating powerful sound. From the switch-mode universal power supply to the efficient performance of Crown's DriveCore's Technology, we continue to set new standards in commercial power amplifier technology.

Simple to configure, the CSA amplifiers provide a DriveCore-based sound solution. This replaces up to 500 parts with one small chip, significantly reducing the part count and increasing reliability while maintaining superb performance.

Supporting 70V and 100V installations out of the box, CSA amplifiers include RJ45 connectors for use with JBL CSR-V in-wall volume controls. Its universal power supply allows every CSA amp to accept AC voltages from 100 to 240 VAC, 50/60 Hz. And with HARMAN's GreenEdge™ environmental initiative, CSA amplifiers quickly pay for themselves in energy savings.



- 1 or 2 output channels with 40W, 80W, 120W per channel Built-in 70V and 100V
- Fanless, space-saving 1U design
- Sleep mode disable function
- Energy-efficient amplifier
- Sleek industrial look with illuminated rings making knobs easy to see and use
- Supports the JBL CSR-V wall controller via Ethernet cable
- Universal power supply

SPECIFICATIONS			
Model	Power Output (per channel)	Output Channels	Size
CSA140Z	40W	1	1U Half-Rack
CSA180Z	80W	1	1U Half-Rack
CSA1120Z	120W	1	1U Half-Rack
CSA240Z	40W	2	1U Half-Rack
CSA280Z	80W	2	1U Half-Rack
CSA2120Z	120w	2	1U Half-Rack

CSA-2120

2 X 120W AUDIO AMPLIFIER

A professional-grade, two-channel model, the CSA-2120 power amplifier provides simple analogue front-end processing. Delivering 2 x 120W at 4 and 8 ohms, this efficient, lightweight unit is convection-cooled and has an auto-standby mode to save energy.

The CSA-2120 is a professional-grade power amplifier built for commercial and installed sound applications. The amplifier is a two-channel model providing simple analogue front-end processing with a switch-mode universal power supply.

- Auto-standby mode for energy savings
- Balanced (Euroblock) and unbalanced (RCA) mono-summing inputs
- 1U lightweight design
- Plenum rated
- Over-heat auto protection
- Switch-mode universal power supply
- 2 x 120W at 4 and 8 ohms
- Compact size (1.75inH x 8.2inW x 9inD) Lightweight (under 4 lbs.)
- Optional Transformer Kit: CST-2120 for Hi-Z applications.

SPECIFICATIONS	
CSA Output Power	120W Per Channel
CSA Channels	2
CSA Sensitivity (8 ohms load)	1.4 Vrms
CSA Signal to Noise Ratio	>100dB
Weight & Size	1.3kg, 1U, Half Rack

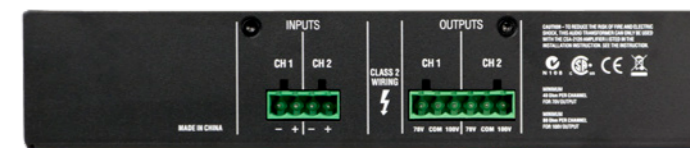

CST-2120

70V/100V TRANSFORMER KIT

The JBL CST-2120 transformer module comes with a rack mounting kit so you can install it to a cabinet or wall. It supplies impedance and voltage matching from the CSA-2120 amplifier (with 4 and 8 ohms outputs) to drive 70V and 100V distributed speaker systems.

- Providing two channels for constant voltage operation
- 70V/100V Outputs
- Rack-mountable with CSA2120
- Detachable block input and output connectors.



Mixer/Amplifiers.

COMMERCIAL SERIES MIXER/AMPLIFIERS

Mixer/Amplifiers.

COMMERCIAL SERIES MIXER/AMPLIFIERS

VMA 160 / 1120 / 1240

COMMERCIAL MIXER AMPLIFIERS



The JBL VMA Series is a cost-effective line of Mixer/Amplifiers with low impedance functionality (4Ω, 8Ω) and high impedance 70V and 100V output. They are designed with convenient and flexible features to be used by commercial integrators worldwide.

- 5 inputs with 1 output of 60, 120, or 240W of power
- Independent bass and treble controls for each output channel
- 100V and 70V output, or 4Ω/8Ω
- Paging Chime, and Priority muting
- Works with JBL CSR-V wall controllers
- Balanced mic/line inputs; RCA (.775V) inputs
- Rack mounting hardware included



SPECIFICATIONS				
Model	Power Output (per channel)	Inputs	Output Channels	Size
VMA160	60W	5	1	2U Full Rack
VMA1120	120W	5	1	2U Full Rack
VMA1240	240W	5	1	2U Full Rack

VMA 260 / 2120

COMMERCIAL MIXER AMPLIFIERS



The JBL VMA Series is a cost-effective line of Mixer/Amplifiers with low impedance functionality (4Ω, 8Ω) and high impedance 70V and 100V output. They are designed with convenient and flexible features to be used by commercial integrators worldwide.

- 8 inputs with 2 outputs of 60 or 120W of power
- Independent bass and treble controls for each output channel
- 100V and 70V output, or 4Ω/8Ω
- Paging Chime, and Priority muting
- Works with JBL CSR-V wall controllers
- Balanced mic/line inputs; RCA (.775V) inputs
- Rack mounting hardware included

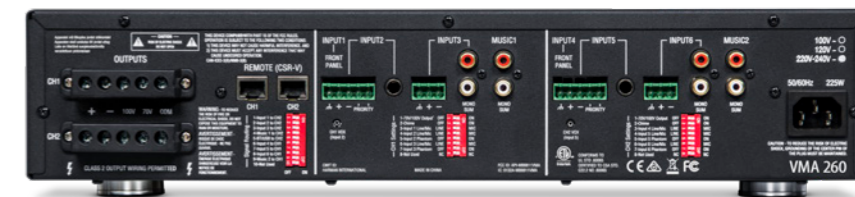

SPECIFICATIONS				
Model	Power Output (per channel)	Inputs	Output Channels	Size
VMA260	60W	8	2	2U Full Rack
VMA2120	120W	8	2	2U Full Rack

Mixer/Amplifiers.

COMMERCIAL SERIES MIXER/AMPLIFIERS

CSMA 180 / 1120 / 240 / 280 / 2120 COMMERCIAL MIXER AMPLIFIERS

Innovation is always evident throughout the JBL Commercial Series product lineup, and our new high-performance, energy-efficient Commercial Series Mixer-Amplifiers (CSMA) represents the latest example.

Manufactured using HARMAN's Green Edge™ clean standards, including a low-energy powder coat that uses 33% less energy, CSMA units conform to lead-free RoHS standards. By incorporating Crown's exclusive DriveCore technology, they also deliver unsurpassed reliability, thermal management and power efficiency.

Offering unmatched ease of use and driving 8 ohm and 4 ohm loads, CSMA units include balanced mic/line inputs, unbalanced RCA inputs and speaker connections, and RJ45 connectors to use with JBL CSR-V in-wall volume controls.

DRIVECORE™



SPECIFICATIONS

Model	Power Output (per channel)	Inputs	Output Channels	Size
CSMA180	80W	4	1	1U Half-Rack
CSMA1120	120W	4	1	1U Half-Rack
CSMA240	40W	8	2	1U Full-Rack
CSMA280	80W	8	2	1U Full-Rack
CSMA2120	120W	8	2	1U Full-Rack

- Fanless, space-saving 1U design
- Configurable output routing (2 channel only)
- Independent bass/treble controls for each output channel
- Euro-block type mic/line input and output connectors, and unbalanced RCA inputs for consumer connection
- Supports 70V and 100V distributed audio systems without needing a separate transformer
- Remote volume control capability using JBL CSR-V module and standard Ethernet cable
- Priority muting, VOX ducking, and phantom power for all models

Mixers.

COMMERCIAL MIXER & PUBLIC ADDRESS MIXER

Easily configured for a range of applications, such as background music, security, and paging, CSM units are designed for everything from schools and hospitals to restaurants and fitness facilities. They feature RJ45 connectors for use with JBL CSR-V in-wall volume controls, and a universal power supply that accepts AC voltages from 100 to 240 VAC, 50/60 Hz. Plus, they're built using HARMAN's GreenEdge™ clean standards to offer numerous energy-efficient benefits, including a lighter weight, space-saving design, and conforming to RoHS standards.

CSM-14 & CSM-28 COMMERCIAL MIXERS



The JBL® Commercial Series CSM-21 and CSM-32 Mixers offer a wide array of processing tools, including priority override, page ducking, source and zone EQ, and a built-in crossover.

Helping maintain optimum levels through the system, LevelGuard™ automatically applies the right amount of compression to the source signals based upon the incoming level.

AutoWarmth™ automatically adjusts the tonal balance within a zone based upon the zone output level, preventing music from sounding thin at lower levels or excessively resonant at higher levels.



- Fanless, space-saving 1U design
- Independent base/treble controls
- Euro-block type mic/line input and output connectors, and unbalanced RCA inputs for consumer connection
- Sleek industrial look with illuminated rings making them easy to see and use
- Configurable output routing (2 channel models only)
- Supports JBL CSR-V wall controller via Ethernet cable
- Priority muting, VOX ducking, and phantom power for all models

SPECIFICATIONS

Model	Inputs	Output Channels	Size
CSM-14	4	1	1U Half-Rack
CSM-28	8	2	1U Full-Rack

CSM-21 & CSM-32 PUBLIC ADDRESS MIXERS

The JBL® Commercial Series CSM-21 and CSM-32 Mixers offer a wide array of processing tools, including priority override, page ducking, source and zone EQ, and a built-in crossover.

Helping maintain optimum levels through the system, LevelGuard™ automatically applies the right amount of compression to the source signals based upon the incoming level.

AutoWarmth™ automatically adjusts the tonal balance within a zone based upon the zone output level, preventing music from sounding thin at lower levels or excessively resonant at higher levels.

CSM-21



CSM-32



SPECIFICATIONS

Model	Stereo Source Inputs	Paging Microphone Input	Direct Input	Stereo Zone Outputs	Dedicated Subwoofer Output	Music-on-hold Output	Stereo/Mono Operation	Music Mute	Page Assign
CSM-21	2	Yes	Yes	1	Yes	-	Yes	Yes	Yes
CSM-32	3	Yes	Yes	2	Yes	Yes	Yes	Yes	Yes

Wall Controllers.

SOLID CONTROL AT YOUR FINGERTIPS

The JBL Commercial Series remote wall controllers offer source selection and/or volume control from an elegant user interface. Using Cat. 5 cable and installation-friendly RJ-45 connectors, the controllers can be placed up to 1000' (305m) from the CSM mixer.



HARMAN PROFESSIONAL TRAINING



CSR-V 1-ZONE WALL CONTROLLER

- Volume Control
- RJ-45 / Cat. 5 Connection
- Up to 1000' (305m) from CSM device
- For use with all CSMA, CSM, and CSA (Z) models
- Available in Black or White



CSR-2SV 2-ZONE WALL CONTROLLER

- Volume Control
- Source Selection (2 Sources)
- RJ-45 / Cat. 5 Connection
- Up to 1000' (305m) from CSM device
- For use with CSM-21 and CSM-32
- Available in Black or White



CSR-3SV 3-ZONE WALL CONTROLLER

- Volume Control
- Source Selection (3 Sources)
- RJ-45 / Cat. 5 Connection
- Up to 1000' (305m) from CSM device
- For use with CSM-32
- Available in Black or White



HARMAN PROFESSIONAL TRAINING

Take the time to upskill and expand your knowledge by leveraging the learning sessions on offer by HARMAN Professional Training. Facilitated by leading industry experts and HARMAN product specialists, HARMAN Professional Training provides the information, training or certifications needed to understand, sell, plan, design, install, program, and configure HARMAN Professional products and solutions accurately and effectively.

The training modules range from short bite-sized videos on specific products and technologies, through to face to face, instructor-led training, detailed webinars and certification courses. Whether you are just starting

your career in audio, or you are an industry professional looking to maintain or develop your qualifications, the Certification pathway is structured to suit you.

You can either follow the learning pathway from foundation learning through to examination, or you can jump straight to final examinations if you have the capability and confidence. Instructor-led courses which are eligible for 8 InfoComm / AVIXA RU Credits include HARMAN Pro Audio Designer and Audio Programmer (Audio Architect).

EXPLORE THE ALL NEW TRAINING PROGRAMME



ONLINE COURSES



INSTRUCTOR LED



CERTIFICATION



WEBINARS



PRODUCT VIDEOS

VISIT WWW.HARMAN.REMOTE-LEARNER.NET/ TO DEVELOP YOUR LEARNING JOURNEY

CBT Calculator.

JBL's CBT Calculator software is a precision engineering tool allowing audio professionals to design JBL's CBT Constant Beamwidth Technology line array column loudspeakers into a wide variety of venues.

CBT Calculator shows the vertical coverage of CBT models in venues via a cross-sectional sound level coverage display. The program allows the use of up to 3 CBT speakers and virtual adjustment of their various adjustable settings for vertical coverage (narrow or broad) and voicing (speech or music/flat), in a space with up to 4 independent listening planes.

In addition to the SPL vertical coverage mapping of a proposed design, the CBT Calculator also shows the frequency response for up to 6 listener locations as well as an SPL summary of the listener locations over user-defined frequency bands.



It helps designers to determine the best CBT model selection, the proper vertical coverage and voicing settings, mounting height and the down-angle, allowing audio professionals to design CBT column line array speakers into many venue-application types.

VLA-C Calculator.

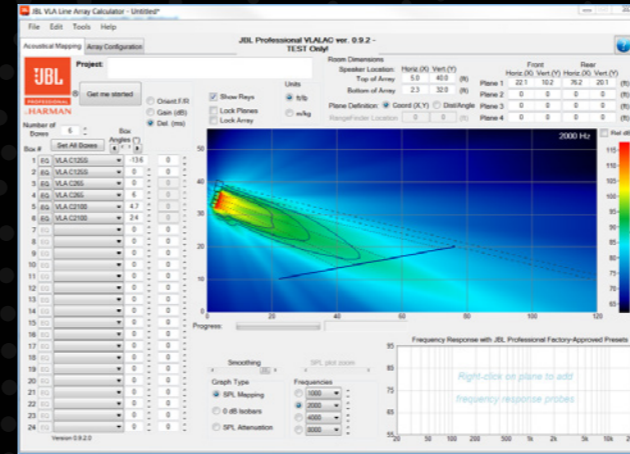

The free VLA-C Calculator is simulation software for designing and predicting JBL VLA-C Series systems.

The Acoustical Mapping tab allows for 2D sectional-view modeling of VLA-C arrays on up to four seating planes. Included are both patterns of the VLA-C full-range boxes (VLA-C265 and VLA-C2100) and the subwoofer (VLA-C125S). Mixed arrays may be modeled.

The Array Configuration tab describes the array and provides information about weight factors and centre of gravity (CG), along with mechanical validation of the array. The array weight design factor is selectable between 5:1, 7:1, and 10:1. Frame options are selectable. If the array configuration falls outside the load limits of either the speaker cabinets, the speaker interconnect system, or the suspension system, this will be indicated via an error indication. Array statistics like total weight, attach point span, and array height and depth are also calculated.

Ceiling Speaker Configurator (CSC) and Distributed System Design (DSD) Software

CSC is a general sales estimation tool for basic projects. It comes up with a few ideas about which ceiling speaker could be used and approximately how many. This free utility program helps select the most economical JBL ceiling speaker to use based on various characteristics of the project, based on desired music level (for music systems) or background noise level (for paging systems).

The intention is that the use will then model the project more completely in the DSD Distributed System Design software to determine how/whether the various possibilities from CSC might work for the project. DSD allows the user to change the design for "what if" scenarios: What will happen if we change the design to a different loudspeaker model, to a different tap setting, to a different density factor, etc? What happens if we trim the pendant speakers at a different height? What impact would different changes have on the number of speakers required, the layout distance between speakers, the resulting sound level, the level variation throughout the space, the required amplification, etc?

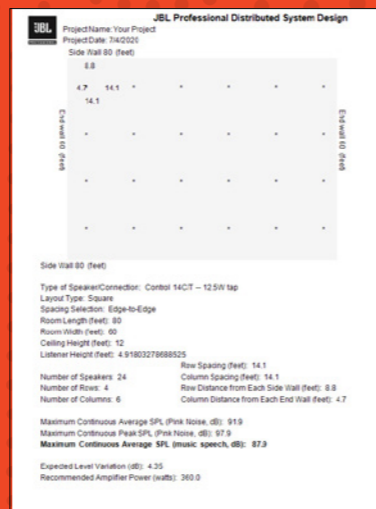
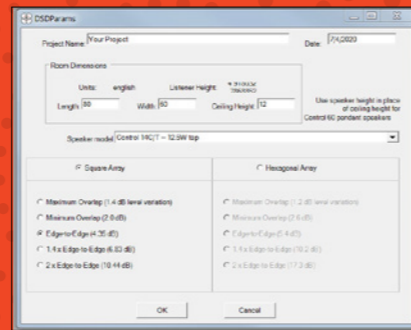

DDA (Digital Directivity Analysis).

DDA is a powerful yet intuitive Windows application for accurately predicting the electro-acoustic performance of loudspeaker systems in (semi) open or closed spaces. It includes 3D room acoustic modelling, direct sound simulation as well as statistical prediction of various acoustic parameters.

DDA supports all JBL point source loudspeakers with CLF data and all JBL Intellivox products. Intellivox makes use of JBL's advanced beam shaping (DDS) technologies. From DDA the radiation pattern of JBL Intellivox loudspeaker arrays can be controlled precisely and tailored to the shape and the acoustics of the space. In addition, DDA offers various design tools which reduce design time and help the sound designer to optimise the system performance. For installation and commissioning purposes DDA also generates FIR output filters which can be uploaded to supported DDS-controlled loudspeaker arrays using the JBL WinControl software.

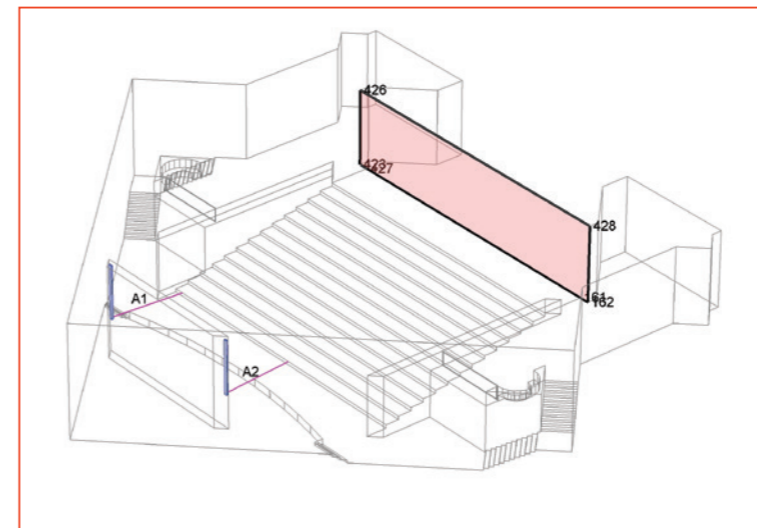



2023 Install Full Line Product Catalog



Find your local JBL representative: jblpro.com/en/distributors